

# 2020 Indiana 4-H Horse and Pony Handbook



15th Edition, October 2019  
This handbook is the property of

Name \_\_\_\_\_

Address \_\_\_\_\_

County \_\_\_\_\_ Phone \_\_\_\_\_

Purdue University Cooperative Extension Service  
West Lafayette, Indiana

*NOTE: Some classes may not be offered at the State 4-H Show.*

**Cover photo:** Rebecca Kluesner, a 4-H member in Gibson County, and Cheyenne. Rebecca leases her horse from Sky Epperson who, while never in 4-H himself, offered his horses and his time to teach Rebecca and her sister how to ride so they could realize their dream of showing horses.

## Contents

### 4-H Program Policies

Mission, Vision, Objectives, Goals and Philosophy.....	2
4-H Member Classification.....	4
Animal Classification, Measurement Procedures.....	4
Approved Protective Attire.....	4
Show Guidelines .....	5
Ownership .....	6
State Fair Eligibility Requirements .....	7
State Fair Ownership Requirements.....	7
Division of Show Responsibilities .....	8

### Class Specifications

#### Show and Equipment Rules

Disqualifications for All Classes.....	10
Halter .....	10
Showmanship at Halter.....	13
Hunter Type Tack and Attire .....	14
Hunter Hack.....	15
Hunter Over Fences .....	17
Hunt Seat Equitation on the Flat .....	19
Hunt Seat Equitation Over Fences .....	20
Hunter Under Saddle .....	22
Show Jumping.....	22
Show Jumping-in-Hand.....	24
English Saddle Type Tack and Attire .....	26
Saddle Seat Equitation .....	27
Saddle Seat Pleasure .....	28
Gaited English Pleasure .....	28
Pleasure Driving .....	29
Reinsmanship .....	30
Obstacle Driving .....	31
Western Tack and Attire .....	32
Western Horsemanship.....	35
Western Pleasure.....	36
Gaited Western Pleasure.....	37
Ranch Pleasure.....	37
Ranch Riding.....	39
Versatility.....	42
Western Riding.....	43
Trail .....	48
In-Hand Trail.....	54
Reining.....	55
Barrel Race .....	61
Flag Race.....	62
Keyhole Race.....	64
Pole Bending .....	65
Speed and Action.....	67
Dressage.....	68
Walk-Trot Equitation/Horsemanship.....	72
Leadline Equitation.....	73
Glossary.....	75
References.....	79

*Note: Some classes may not be offered at the State 4-H Show*

**Authors:** C. Brady and M. Russell

**Contributions from:** State 4-H Horse and Pony Advisory Committee  
15th Edition October 2019

## 4-H PROGRAM POLICIES

**4-H Mission:** The Indiana 4-H Youth Development mission is to provide real-life educational opportunities that develop young people who will have a positive impact in their communities and the world.

**4-H Vision:** Indiana 4-H Youth Development strives to be the premier, community-based program empowering young people to reach their full potential.

### Objectives

4-H events, activities, and experiences serve as building blocks through which 4-H members' self-confidence, inquiry, interpersonal cooperation, concern for community, and decision-making skills are developed.

The objectives of the Indiana 4-H Horse and Pony program are:

1. To develop leadership, initiative, self-reliance, sportsmanship and other desirable character traits.
2. To develop an appreciation of horse well-being and proper horsemanship.
3. To experience the pride and the responsibilities of owning a horse or pony.
4. To learn good horsemanship and an understanding of proper management for breeding, raising and training horses and ponies.
5. To provide an opportunity to observe and learn through participation and observation.
6. To accept constructive criticisms and learn new ways of training and caring for animals.
7. To provide an opportunity for educational experiences through county, area and state functions.

### Goals and Philosophy

1. The Indiana 4-H Horse & Pony Handbook is a training manual for 4-H members, parents, horse show judges, and 4-H volunteers throughout the state of Indiana.
2. Due to the variations in size, organization, and youth interests of the county horse & pony programs, counties have the right to adapt or add to these rules to meet local needs.
  - a. The county Extension 4-H/Youth Educator has the final say in using or changing class rules and specification for their respective county shows.
  - b. Although the State Fair may be the capstone exhibition for many youth, counties should not directly adopt policies from the Indiana State Fair show without considering how those policies fit their county.
3. 4-H is by policy an inclusive organization.
  - a. No county policy or practice should be used to arbitrarily exclude youth from either membership or participation.
  - b. Youth should participate in 4-H Youth Development opportunities at levels and times that best suit the youth's development and support family involvement.
  - c. County 4-H policy is guided by the county 4-H policy-making or governing board (i.e., 4-H council) as provided by the County Extension Board.

4. Extension employees and volunteers are obligated to eliminate (and should not create) any practices that limit, deprive, or tend to deprive any youth of opportunities for membership and/or participation in the Indiana 4-H Program.
5. Because the 4-H events, activities, and experiences serve as the building blocks for youth development, the more experiences the 4-H member can do themselves, the more the youth benefits. It is expected that the member do most of the management, riding, lunging, and driving with assistance always being acceptable if/when needed for safety or educational reasons.
6. Rules governing exhibitor safety (headgear and boots) and animal well-being are mandatory at all 4-H horse and pony events and activities, and cannot be altered by county programs.
7. When the 4-H member comes to the Indiana State Fair 4-H Horse & Pony Show, the Class Specifications (Rules) in this manual are strictly followed.
8. Because the Indiana 4-H Horse & Pony program is a multi-breed program, classes offered at shows shall be inclusive of ALL breeds, with the ultimate decision of classes to enter made by the 4-H member and family.

### **Indiana 4-H Horse & Pony Program Policies**

*Please note: Program policies may be updated more frequently than this handbook.* Official Indiana 4-H Program Policies and Procedures override policies in this book; for the most current rules, contact your county educator.

1. When attending, participating, or acting on behalf of the 4-H program, all persons are expected to conduct themselves in accordance with accepted standards of behavior, show respect for others' rights, and refrain from any conduct that may be injurious to the 4-H program.
2. Safety rules governing headgear and boots, and rules addressing animal well-being, are mandatory at all 4-H horse and pony events. Judges have the responsibility to refuse to conduct classes in which these safety rules are not enforced.
3. Inhumane treatment of animals, including a Body Condition Score of less than 3.0, impolite behavior, poor sportsmanship, or disruptive actions, (as deemed by the show management) result in disqualification and/or removal from the grounds.
4. All 4-H Horse & Pony animals participating in 4-H activities must exhibit a minimum Body Condition Score of 3.0, while the preferred BCS is between 4.0 and 7.0 (see AS-552, AS-554, and ID-269 for more information) and must have a current, completed Certificate of Completion of Indiana 4-H Requirements for Exhibition of 4-H Horse and Pony (4-H-1031-W).
5. It is strongly recommended that the Class Specifications (Rules) portion of this Handbook be used as a guide in county programs and be adapted and utilized in a way that reflects the needs of each county. Each county program should determine what to offer to 4-H members based on the county needs and not be restricted to the events offered at the Indiana State Fair.

6. The State 4-H Horse and Pony Advisory Committee shall be the representative of Indiana's 4-H Horse and Pony volunteers and members (Refer to the Advisory Committee Constitution and By-laws for details of the committee structure.)
7. Any situation not covered by these policies and rules shall be handled by the proper representative of the Purdue University Cooperative Extension Service, or their designee.

#### **4-H Member Classification**

1. Any boy or girl in Indiana who is enrolled in 4-H Horse & Pony may participate in 4-H classes and activities, providing he/she meets the eligibility rules for participation.
2. Youth may become 4-H members when they enter the third grade and continue through grade 12. These individuals may continue their 4-H membership for a maximum of 10 years. A child's grade in school is the grade they were in on January 1 of the current year. Children advance one grade/year of 4-H involvement, regardless of academic standing.
3. 4-H Horse & Pony member categories:  
Juniors, 3rd – 5th grade  
Intermediate, 6th – 8th grade  
Seniors, 9th grade and above

#### **Animal Classification**

1. The age of an animal is computed on the basis of a calendar year starting on January 1 of the year foaled. For example, an animal foaled any time in 2010 is considered 1 year old (a yearling) on January 1, 2011, 2 years old on January 1, 2012, etc. Animals 5 years of age and younger are considered junior animals and those over 5 years of age are considered senior animals.
2. Animals may not be ridden in 4-H Horse & Pony competitive events before July 1 of their 2-year-old year for reasons pertaining to the horse's physical development.
3. Animals under 40 inches in height shall not be ridden at 4-H events. It is recommended that the weight of the rider does not exceed 30 percent of the weight of the animal.

#### **Measurement Procedures**

1. The show committee may measure at random, any animal of questionable height.
2. The Indiana 4-H Horse and Pony program considers animals *56 inches and under* to be ponies, and animals *over 56 inches* to be horses.

#### **Approved Protective Attire Headgear**

1. All 4-H members are required to wear a properly fitted ASTM or SEI standard F1163 (or above) certified equestrian helmet whenever mounted or driving at all 4-H horse and pony events, shows, or activities. Original tags must be present in all approved helmets.
2. The 4-H member is responsible to see that this specified headgear is properly fitted with the approved harness fastened in place whenever mounted.

3. Helmet policies apply to all county, area, and state 4-H horse and pony events, shows, and activities.
4. Protective helmets are recommended for all riders and drivers at all times. It is recommended that all adults working with 4-H members model the desired youth behavior by also wearing protective helmets whenever mounted or driving.

### **Vests**

1. Protective vests are recommended in all mounted classes.

### **Show Guidelines**

1. Behavior:
  - a. When attending, participating, or acting on behalf of the 4-H program, all persons are expected to conduct themselves in accordance with accepted standards of behavior, show respect for others' rights, and refrain from any conduct that may be injurious to the 4-H program. Inhumane treatment of animals, impolite behavior, poor sportsmanship, or disruptive actions (as deemed by the show management) result in disqualification and/or removal from the grounds.
2. Animal Well-being:
  - a. All 4-H Horse & Pony animals participating in 4-H activities, must be sound, humanely treated, and healthy and exhibit a minimum Body Condition Score of 3.0, while the preferred BCS is between 4.0 and 7.0. (See AS-552, AS-554, and ID-269 for more information.) Animals are subject to inspection by a licensed veterinarian, and questionable animals may be removed.
  - b. The judge must excuse any animal from the ring he/she deems unsafe, lame, bleeding from mouth or sides, or in any way being treated inhumanely.
  - c. The soundness of an animal as determined by the judge or official veterinarian are not protestable.
  - d. All animals competing must have a current and completed Certificate of Completion of Indiana 4-H Requirements for Exhibition of 4-H Horse and Pony (4-H-1031-W).
3. The 4-H animal may be ridden or driven only by the 4-H member on the day of the 4-H show.
4. If a situation arises where safety is a concern for the 4-H member, other exhibitors, or spectators, the 4-H member should be encouraged to not enter the class(s).
5. All participants in the ring while a class is being judged shall be 4-H members. (An exception is made for attendants and headers in driving classes and for assistants in assisted equitation classes.)
6. 4-H members with special needs are encouraged to show horses, and show management shall allow assistance and rule modifications when appropriate. This includes, but is not limited to, use of adaptive tack and equipment.
7. Equipment that attaches the rider to the saddle or horse in any way is prohibited unless specifically allowed in the class guidelines (i.e., rubber bands in contesting.)
8. In all riding classes, animals must be ridden astride (one leg on each side) of the horse, or with an approved side saddle.

9. Stallions are not eligible to show, except during the calendar year they are foaled.
10. It is recommended that show management provides exhibitors assigned exhibitor numbers for both sides of the saddle pad. Numbers must be in visible position(s) from both sides during the show. Exhibitors with hair covering and/or obstructing the view of their numbers may be penalized.
11. The official show steward/equipment judge should be charged with the authority to interpret 4-H rules.
12. Judge's decisions that represent his/her individual preference are not protestable.
13. Questions concerning rules are to be presented to the 4-H show manager or show steward.

### **Ownership**

The following is an ownership guideline for counties to consider. Each county should adapt ownership guidelines that reflect the needs of their membership. Extension employees and volunteers are obligated to eliminate (and should not create) any practices that limit, deprive, or tend to deprive any youth of opportunities for membership and/or participation in the Indiana 4-H Program.

1. Exhibitor must be enrolled during the current year in the 4-H project exhibited.
2. It is strongly encouraged that enrolled 4-H animals are primarily available to the enrolling 4-H member for their full use in all educational clinics, demonstrations, workshops, trail rides, other 4-H activities, and competitions.
  - a. In an effort to expand opportunities for membership and/or participation in the Indiana 4-H Horse & Pony program, counties may choose to adopt exhibition policies that differ from state policies. This is done at the sole discretion of the county, and therefore such policies may differ between counties. For exhibition policies for your county fair, contact your county 4-H Extension Educator. Refer to State Fair Horse Show Eligibility Requirements for Indiana State Fair eligibility.
  - b. 4-H animals should be in the possession and regular care of the 4-H member who owns/leases them (unless other arrangements have been agreed upon by the county 4-H council) from the animal enrollment Animal ID deadline until the conclusion of the 4-H project.
3. Leasing is considered the equivalent of ownership of a 4-H project animal.
  - a. Horse & Pony animals may be leased subject to approval of both the 4-H horse and pony committee and the respective County Extension Educator. The intent of this county-approved and monitored lease agreement program is to ensure the opportunity for membership and/or participation of all interested youth and that their leased animal is available for their use for all educational clinics, demonstrations, workshops, trade rides, other 4-H activities, and competitions through the lease period.



- b. The 4-H member should be regularly involved in the care of the horse, regardless of where stabled, and should determine her/his primary show use of the animal during the 4-H lease period.

## **INDIANA STATE FAIR HORSE & PONY SHOW ELIGIBILITY REQUIREMENTS**

*The following pertains only to Indiana State Fair 4-H Horse & Pony eligibility. Counties are encouraged to adapt eligibility requirements that reflect the needs of their own county 4-H Horse & Pony program, and should not arbitrarily apply or adapt the Indiana State Fair eligibility requirements for their county.*

1. It is recommended that the same combination of animal and exhibitor entered for the Indiana State Fair 4-H Horse & Pony Show should have shown in the same class in either their county or area show.
  - a. If the same class is not offered, the most similar class should be entered.
2. 4-H horses and ponies exhibited must meet current Indiana State Animal Health Exhibit Requirements and have a current and completed Certificate of Completion of Indiana 4-H Requirements for Exhibition of 4-H Horse and Pony.
3. Refer to current Indiana State Fair Premium Book for all rules regarding Indiana State Fair participation and competition.
4. Horses must be identified in Indiana 4-H Online by May 15 (or earlier deadline set by county). For state fair eligibility, a color picture showing face and all four feet must be uploaded prior to the deadline. Counties may have differing animal ID policies for county fair animals. Contact your County 4-H Extension Educator for county-specific policies.
  - a. Indiana State Fair 4-H Horse & Pony Show entry is different than Indiana 4-H Horse & Pony Animal ID. Both must be completed by specified deadlines for a horse/ rider combination to participate in the Indiana State Fair 4-H Horse Show.

### **Indiana State Fair Ownership Requirements**

1. Exhibitor must be enrolled during the current year in the 4-H project exhibited.
2. Animal must be under the 4-H member's ownership or lease by May 15, and this ownership must be maintained continuously until completion of the State Fair. Records must be started by May 15.
3. Absolutely no animal may be substituted or traded for the original animal after May 15.
4. 4-H animals exhibited at any show after the animal ID deadline — April 1 for steers and May 15 for all other animals — by anyone other than the individual whose 4-H enrollment record is connected to the animal's ID in Indiana 4HOnline are not eligible to be shown in the 4-H show at the Indiana State Fair. This term/condition does not apply to siblings, who may show each other's animals at any show during the year without jeopardizing State Fair eligibility.

4-H animals that are selected by 4-H Extension staff or 4-H adult volunteers for use in supreme showmanship contests (Master Showmanship, Round Robin, etc.) may be used in those county events without jeopardizing State Fair eligibility. This policy applies to all 4-H animal projects. For animal projects without ID deadlines, the person who enters them in the Indiana State Fair 4-H show is the equivalent of the owner of the animals.

5. Leasing is considered the equivalent of ownership of a 4-H project animal. The 4-H member should be regularly involved in the care of the horse, regardless of where the animal is housed, and the 4-H member should have exclusive show use of the animal during the 4-H lease period. 4-H animals (horse and pony, dairy, alpacas and llamas) are eligible to be leased by only one individual 4-H member in a given 4-H program year.

### **DIVISION OF SHOW RESPONSIBILITIES**

In a successful show, all participants clearly understand how responsibilities are divided. This ensures the show fulfills 4-H's mission to provide a safe and educational environment in which youth learn life skills and how to properly care for their animals. The following is a suggested division of responsibilities at a 4-H show.

1. **Show manager:** Organizer of the show, staff, and environment.
  - a. The show manager works with the Extension office to identify and secure the judge for the show. The show manager is responsible for ensuring that all other positions are filled with qualified individuals, and is involved in all decisions made outside of the judging ring on the day of the show. The show manager is ultimately responsible for ensuring that all policies, procedures, and show guidelines for the event are followed.
2. **Judge:** Responsible for all activity within the ring.
  - a. The judge should arrive at the show a minimum of 30 minutes prior to the beginning of the first class and plan to remain through completion of the day's showbill. The judge should come to the show having completed any patterns that were his or her responsibility based on earlier discussions with show management. The judge is obligated to follow the show rules and guidelines as provided by the show manager, and is obligated to disqualify from the ring any horses that are a danger to their rider or other, lame, or otherwise unfit for show. This includes horses that are severely underweight (refer to show guidelines), or show evidence of having been inhumanely treated.
3. **Show steward:** Responsible for interpreting and implementing rules and policies outside of the show ring.
  - a. In some shows, the show steward and show manager may be the same person. The show steward should ensure that all animals that enter the ring meet requirements related to tack, equipment, and fitness to

show. Show stewards should notify participants of improper tack and equipment in a timely manner so adjustments can be made that allow the youth to participate. The show steward should also work with the show management, Extension office, and programmatic governing body to ensure that horses that body condition score less than a 3 do not enter the show ring.

4. **Ring steward:** Assists the judge in directing exhibitors in the ring, and in whatever other ways the judge requests assistance.
  - a. The ring steward should be attired in long pants, boots, and a shirt with a collar when working in the ring. The steward's job is to assist the judge, not advise the judge on the class, or share information about exhibitors in the class.
5. **Gate steward:** Ensures safe entry and dismissal from the arena. Helps staff and exhibitors determine the appropriate method of entry. Informs the ring steward when the class is complete.
6. **Announcer:** Responsible for communicating the activity in the ring with the show participants, as well as announcing the results of classes.
  - a. The announcer and the ring steward should have a communication method for passing along the requested information of the judge to the announcer's stand.
  - b. It is recommended that the announcer share a brief description of the class with the audience.

# CLASS SPECIFICATIONS

## SHOW AND EQUIPMENT RULES

The following class specifications are to be used as **guidelines** for 4-H horse shows. Counties have the right to **adapt** or **add to** these guidelines to meet local needs and interests. Exhibitors' safety and inclusion should always be priorities when adapting and adding guidelines.

These class specifications are followed at the Indiana State Fair 4-H Horse & Pony Show.

The following disqualifications apply to **all** performance and riding classes.

### **Disqualifications**

1. Exhibitor's failure to control animal, endangering self or others, as determined by judge or the ring steward.
2. Fall of animal and/or rider.
3. Unsoundness as determined by judge.
4. Equipment failure causing an unsafe condition, as determined by judge. Note: This includes loss of helmet.
5. The use of illegal or prohibited equipment or attire in any class.

### **HALTER**

#### **Purpose**

Halter competition can be divided into Western, Hunter, Saddle Type, Miniature, Draft, etc. Animals are to be judged on conformation, type, soundness, way of moving, and general balance and appearance. Members learn to appreciate horse quality and evaluation criteria.

#### *Special Notes:*

1. The Mare and Foal class is judged as a production class. The mare with her foal of current year, weaned or not, are to be exhibited. Conformation and quality of both the mare and foal are to be considered, as is the relative quality of the foal in respect to the dam. This class is intended to encourage and recognize members who choose to breed and improve the quality of their project mares.
2. Weanlings, yearlings and 2-year-old animals must be shown at the height of the dam, unless their height exceeds that of the dam. If the dam's height is unknown, the animal shows in the over 56 inches class. Animals may be measured by the show committee.

#### **Tack and Attire**

1. Refer to requirements for Hunter, Saddle Type, and Western classes.
2. Show sticks in draft halter are allowed.

## Class Procedures and Guidelines

1. The animal is to be judged individually both standing and at a walk and trot (or equivalent breed gait), with exhibitors following the instructions of the judge or ring steward.
2. Champion is selected from first-place winners of classes in a division. Reserve Champion is selected from the second-place winner in the Champion's class and the first-place winners in the other classes in that division. Winners of the Mare and Foal class do not compete for Champion and Reserve Champion awards.
3. In the Mare and Foal class, both handlers must be 4-H members.
4. The 4-H member must show with and maintain control of the lead or reins throughout the entire class or be penalized.
5. The mare may accompany its foal in a foal class, but the foal may not accompany its mare in a mare class. Handlers must be 4-H members.
6. Tailer (an assistant) not permitted.

## Example Halter Class Procedures

The following are examples; other class procedures may be used.

### Example 1: Western Procedure

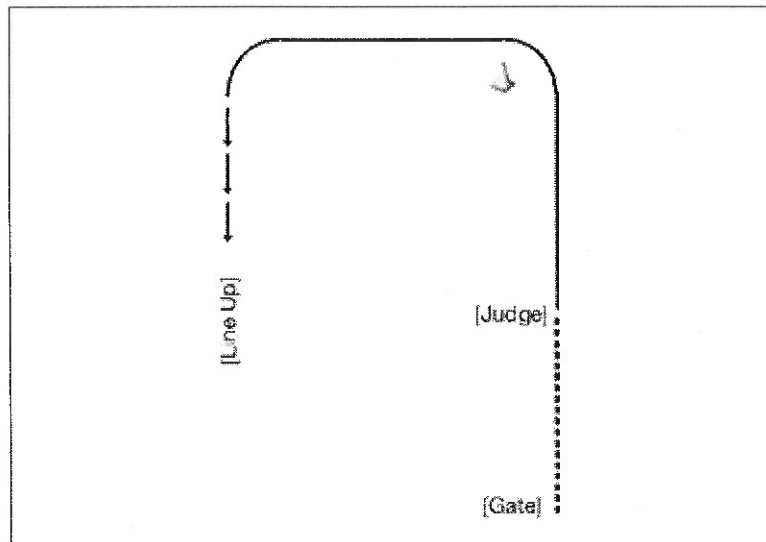

1. Exhibitors walk straight from gate to judge.
2. Trot straight away from judge past cone and turn left and trot a profile.
3. Line up head to tail as instructed for close inspection

### Example 2: Hunter/Saddle Type Procedure

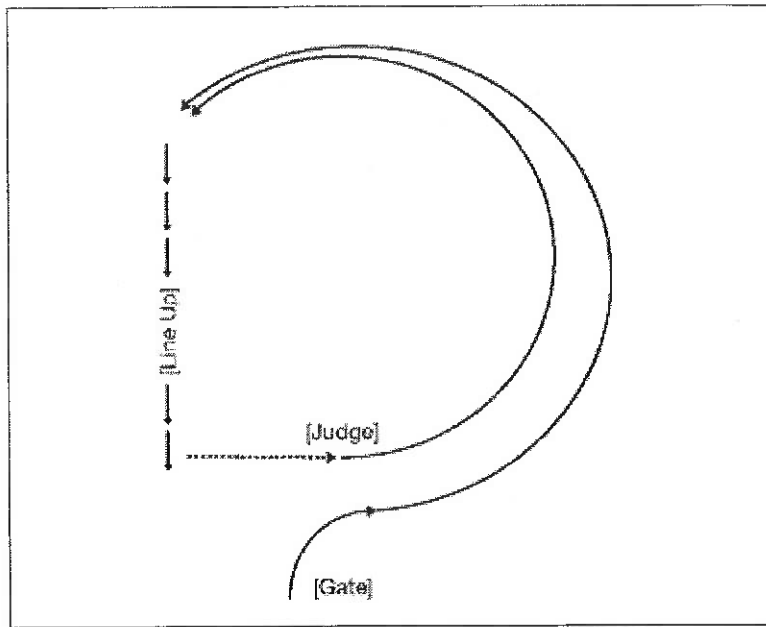

1. Exhibitors walk straight from gate to judge.
2. Trot straight away from judge past cone and turn left and trot a profile.
3. Line up head to tail as instructed for close inspection.

### Example 3: Draft Horse Procedure

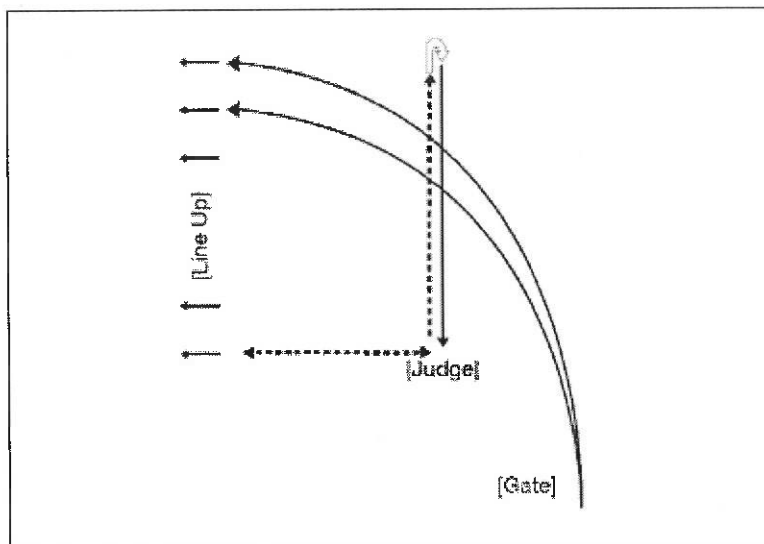

1. Enter trotting to a head-to-tail side-by-side line up.
2. Beginning with the first entry, individually walk to judge in the arena center and set up for close inspection.
3. Walk straight away from judge and turn and trot back the same line to judge.
4. When excused, return to the original line up.

## **SHOWMANSHIP AT HALTER**

### **Purpose**

The showmanship exhibitor is judged on his or her ability to fit, groom, and show an animal at halter. The animal is merely a prop to show the ability of the showman.

### **Tack and Attire**

1. Refer to Hunter, Saddle Type, Western classes tack and attire.
2. Chain may be run under the chin (preferred), or over the nose (accepted). The chain may not be run through the mouth or under the lip of the horse.

### **Class Procedures and Guidelines**

1. Type, conformation, and quality of the animal are not to be considered. Class judged strictly on the contestant's ability to fit and show a halter animal: appearance of animal 40%, appearance of exhibitor 10%, and showing animal in ring 50%. Fitting, grooming, manners, and response to the showman indicates the degree of training and preparation attained by the exhibitor, and must be credited accordingly.
2. The judge may ask the exhibitor questions concerning horse management and conformation. Questions should be commensurate with the exhibitor's age.
3. The judge may not ask the exhibitor to change animals with another exhibitor during the class.
4. Individual patterns are required. Patterns may be posted in advance or may be announced to exhibitors in the show ring.
5. Animals are led into the ring as directed by the judge or ring steward.
6. The animal is to be led from the left side, with the right hand controlling the animal. The right hand must not hold the chain portion of the lead, nor the bit if showing with a bridle. The excess lead or rein is held in the left hand in a loose coil or completely uncoiled. At no time is the lead or rein to be wrapped around the hand or held in a tight coil.
7. When reversing direction more than 90 degrees, the animal must be turned to the right, with the exhibitor walking around the animal.
8. The exhibitor must show with the lead or curb rein, without kicking or handling the animal to position feet.
9. The judge must have a clear, unobstructed view of the animal at all times. The exhibitor must be in a position that enables him or her to watch both the judge and the animal at all times, but must not stand directly in front of the animal. See illustration of Showmanship Safety Zone, next page. Handlers of Saddle type horses that are shown western, may wear western attire.

## Showmanship Safety Zone Diagram

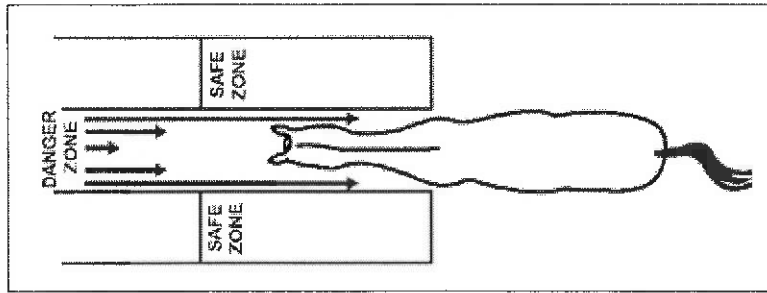

### Disqualification

1. Chain running through the mouth, or under the lip of the horse.

## HUNTER TYPE TACK AND ATTIRE

### Hunter Tack - Halter and Showmanship

1. The animal is to be shown in either a halter or a bridle.
2. The halter must be plain and without decoration, made of leather, nylon, or rope, adjusted to fit properly with a throat latch strap. A lead strap or rope with or without chain is permissible. If the lead is equipped with a chain, the chain may be run through the rings of the halter in a manner that gives the exhibitor the most control of the animal, but may not be through the animal's mouth.
3. The bridle must be hunter style as described below. If using a snaffle bridle, the animal is led with the single rein. If using a Pelham or full bridle, the snaffle rein is on the withers and the animal is led with the curb rein.
4. Optional: Additional hair in horse's tail, braided mane and tail, or braided mane.
5. Prohibited: Dropped or figure eight cavesson nosebands; crop; whip; bit converters; decorated, English or Arabian type show halter or bridle; braided tail without braided mane; curb straps or chains on snaffle bits.

### Hunter Tack-Performance

1. Saddle must be hunter or forward seat style, with or without knee rolls or padding.
2. Bridle is to be hunter style with plain or rolled leather browband and regular cavesson noseband. The bit used may be any snaffle (jointed [2 or 3 pieces] or straight mouthpiece and no shanks), a Pelham (two sets of reins), a Kimberwick, or a full bridle (two sets of reins with separate bits and cheek pieces). Examples of acceptable hunter bits are: Slow Twist, Corkscrew, Double Twisted Wire, French Link Snaffle, Kimberwick, Single Twisted Wire, Loose Ring, and Fixed Port Steel Pelham. Any bits with cathedral or donut mouthpieces, rough, sharp materials such as screw mouthpieces or mechanically altered bits are illegal and are cause for disqualification. Curb chains must be at least 1/2 inch wide and lay flat against the animal's jaw. See Western Tack - Performance for illustration of acceptable curbs. Mouthpiece may be rubber, copper, twisted wire, etc. but must be a minimum of 3/8 inch in diameter 1 inch in from the cheek



- piece. Any bit having a fixed rein requires the use of a curb strap.
3. Optional: Hunt type breastplate; crop (maximum of 24 inches long); additional hair in horse's tail; braided mane; braided mane and tail.
  4. Prohibited: Dropped or figure eight cavesson nosebands; bit converters; any equipment or bit that judge, show steward, or show officials consider to be unduly severe or unsafe; braided tail without braided mane; curb straps or chains on snaffle bits.
  5. Note: Additional optional and prohibited tack pertaining to specific classes is noted in rules for that class.

### **Hunter Attire**

The exhibitor must wear knee-high hunt boots or Jodhpur boots, and solid color (not white, white is for dressage) hunt breeches or jodhpurs. A long-sleeved shirt or blouse is required when a coat is not worn, but a short-sleeved shirt may be worn under a hunt coat. A hunt coat is recommended but not required. Hunt coats should be of a conservative color, never red. Tie, stock, or choker is required. Hair must be neat and contained, as in a braid or hairnet and must not obscure exhibitor number. Traditional attire is preferred. The ASTM and/or SEI standard F1163 (with original tags intact) or above approved protective helmet is required in all hunter type classes, while mounted or driving. Hunt caps are allowed in in-hand classes. Judges must not discriminate against the use of protective vests by 4-H members in any class. See page 4 for description of approved protective headgear.

1. Optional: Gloves; un-roweled spurs in performance classes; paddock boots and boot-like half-chaps instead of hunt boots
2. Prohibited: Spurs in halter and showmanship classes; roweled spurs at any time, white breeches; curb straps or chains on snaffle bits.

### **HUNTER HACK**

#### **Purpose**

The Hunter Hack should be sensible and well-mannered, providing a quiet and comfortable ride both on the flat and over two low fences. The judge considers way of going, style over fences, and even hunting pace. Placings in the class are determined by allowing the maximum of 30% for work on the flat.

#### **Tack and Attire**

1. Refer to Hunter type tack and attire.
2. Prohibited: Any type martingale, tie downs, draw reins, rubber reins, protective leg wraps or boots.

#### **Class Procedures and Guidelines**

1. Fence Work
  - a. Animals are first required to jump two fences. Exhibitors enter the most appropriate jump height, regardless of animal size. County shows are encouraged to offer classes

at lower heights or crossrails appropriate to the members' skills and experiences. Jumps to be set either at the wall to allow flat work travel toward the inside of the ring, or far enough off the wall to allow flat work travel safely between wall and jumps, and 36, 48, or 60 feet apart. A ground line and standards with wings are recommended for each jump. Exhibitors should not be permitted to walk the two fences. At the State Fair, Hunter Hack fences are set at 2 feet in height for novice skill level and 2 feet, 6 inches in height for advanced skill level.

- b. Faults over fences are scored as in Hunter Over Fences Class.
2. At the discretion of the judge, contestant may be asked to hand gallop, pull up, and stand quietly following the last fence.
    - a. Animals being considered for an award then are to be shown at a walk, trot, and canter both ways of the ring with light contact.
    - b. When necessary to split large classes by running more than one go round, finalists must both be re-jumped and reworked on the flat.

### Fence Work Examples

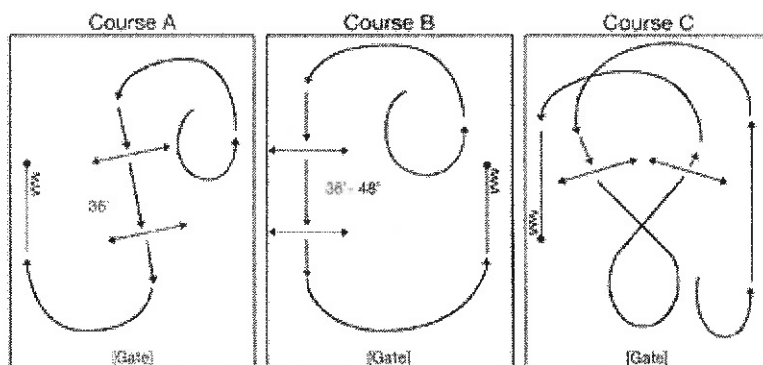

3. Rail work to follow fence work.
  - a. Entry is worked at a walk, trot, and canter, both directions of the ring. If asked to back, animal must back easily and stand quietly.
  - b. While working on the rail, the order to reverse should be executed by turning to the inside (away from the rail). The exhibitor may be asked to reverse at the walk or trot at the discretion of the judge, but shall not be asked to reverse at the canter.
  - c. A Hunter should work with light mouth contact without undue restraint. The animal's response to the rider is emphasized in judging.
  - d. Rider shall not be required to dismount except in the event the judge wishes to check equipment.
  - e. Entry shall be penalized for being on the wrong lead, but not necessarily disqualified. Excessive speed; slowness; short, quick strides; and breaking gait are to be penalized.
  - f. A judge may ask for extended gaits during the rail work.

## **Scoring**

See Hunter Over Fences.

## **Faults**

Unsafe jumping style  
Being on wrong lead  
Excessive speed/slowness  
Head too high/too low  
Nosing out or flexing behind the vertical

## **Disqualifications**

1. Three refusals during fence work.

## **HUNTER OVER FENCES**

### **Purpose**

The Hunter Over Fences class is designed to test the animal and rider over a course of obstacles like those found in the hunt field. The judge considers manners, way of going, and style of jumping. The animal is judged on its ability to move smoothly through a course of jumps with even striding. Judges emphasize safe jumping and fault any breaks in the rhythm of striding caused by jumping from a spot too close or too far away from the fences or jumping too high. Horses should meet the fences squarely, jump the center of the fences, fold the knees and arch the back.

### **Tack and Attire**

1. Refer to Hunter type tack and attire.
2. Optional: Standing Martingale ONLY.
3. Prohibited: Draw reins, rubber reins, dropped or figure eight nose band, protective leg wraps or boots.

### **Class Procedures and Guidelines**

1. The animal is to be judged over a designated course on hunting pace, manners, style of jumping, and way of moving.
2. Course must have minimum of four different obstacles, and animal must make at least eight jumps with at least one change of direction.
3. Fences shall simulate obstacles found in the hunting field. Possible obstacles might include brush, in and out, box, vertical rails, oxer, coop, crossbar, gate, picket type gates with a pole over them, etc. A triple bar, poles less than 8 feet in length, poles less than 4 inches in diameter, bales of hay or straw, tires, and hogbacks are not to be used. Ground rails and wings are recommended for each fence. Fences shall either be made of wood or purchased from a commercial jump company. PVC rails and standards are allowed only if purchased from a commercial supplier and meet current safety standards.
4. Obstacles should be a maximum of 2 feet in height for novice skill level and 3 feet for advanced skill level. Exhibitors should enter the class that is most appropriate to the horse/rider skill level, regardless of animal height. County shows are encouraged to offer classes at lower heights or crossrails appropriate to the members' skills and experiences.

5. Show management must provide at least one practice jump in make-up arena and an opportunity for exhibitors to walk the course without horses.
6. The distance between elements of an in and out obstacle should be set at 24 feet.
7. Judged course is not to be used as practice course.
8. Course must be posted a minimum of one hour in advance of class by show management. The show manager should determine who will design the course, and provide the course diagram, prior to the show.
9. Animals must trot a circle after completing the final fence for soundness evaluation by the judge.
10. The judging starts when the animal enters the arena or 50 feet before the first obstacle on an outside course. The performance is over when the animal leaves the arena or goes 50 feet beyond the last obstacle.
11. Light touches are not to be considered in the judging, but may be recorded for reference in extremely close competition. Touching brush only on brush jumps is not to be scored as a touch. Judges emphasize safe jumping and fault bad form over fences, including twisting, whether touched or untouched.
12. When an animal makes two faults at an obstacle, only the major fault on the top element is considered. Refusals count in addition to jumping faults.
13. When an obstacle contains more than one element, faults are considered on each jumping effort.
14. In case of refusal or run out on an obstacle that contains more than element or jumping effort, entry must re-jump all elements of that obstacle.

### Hunter Over Fences Courses (Examples Only)

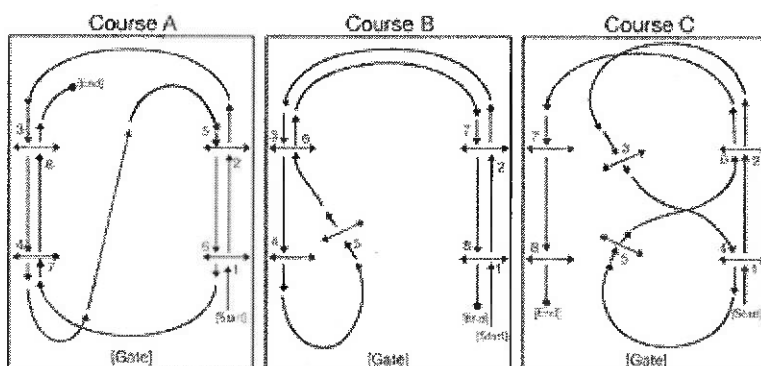

Scoring shall be on a basis of 0-100, with an approximate breakdown as follows:

- 90-100: an excellent performer and good mover that jumps the entire course with cadence, balance, and style.
- 80-89: a good performer that jumps all fences reasonably well; an excellent performer that commits one or two minor faults.
- 70-79: the average, fair mover that makes no serious faults, but lacks the style, cadence, and good balance of the scopier horses; the good performer that makes a few minor faults.

- 60-69: poor movers that make minor mistakes; fair or average movers that have one or two poor fences but no major faults or disobediences.
- 50-59: a horse that commits one major fault,
- 30-49: a horse that commits two or more major faults.
- 10-29: a horse that avoids elimination but jumps in an unsafe and dangerous manner.

### **Faults**

**Minor:** twisting, diving, propping, not centered to jump, hanging a leg, wrong lead

**Major:** knockdown, disobediences (including runouts and refusals), breaking gait

### **Disqualifications**

1. Three cumulative refusals on course.
2. Failing to complete course or being off course.
3. Jumping an obstacle before it is reset.

## **HUNT SEAT EQUITATION ON THE FLAT**

### **Purpose**

The Hunt Seat Equitation class provides an opportunity for the 4-H member to display his or her ability as a rider, i.e., the seat, hand, leg position and ability to control and show the mount as judged. Hunt Seat Equitation is to be evaluated as the combined performance of the animal and rider.

### **Tack and Attire**

1. Refer to Hunter type tack and attire.
2. Prohibited: Any type of martingale, tie down, draw reins, or rubber reins.
3. Traditional attire preferred.

### **Class Procedures and Guidelines**

1. Entries must be asked to execute any appropriate test necessary to judge the riding ability of the rider, prior to rail work. Individual work should be in accordance with the age division's ability. The judge may ask for tests necessary to judge the extent of the rider's ability.
2. Selected or all riders must be worked at a walk, trot, and canter, at least one direction of the ring. The class may, at the judge's discretion, be asked to extend normal gaits, mount and dismount, and back.
3. While working on the rail, the order to reverse should be executed by turning to the inside (away from the rail). Entries may be reversed at the walk or trot, at the discretion of the judge, but they shall not be asked to reverse at the canter.
4. The rider is to be judged on his/her basic position in the saddle; hand, seat, and foot positions; diagonals at the trot; his/her ability to control and show the animal; and the suitability of the animal to the rider. The performance is not to be considered more important than the rider's method to obtain performance.

5. Hand Position: Should be light and educated and held in any easy position. There should be light contact with animal's mouth. The method of holding reins is optional, except that both hands shall be used and all reins must be picked up at one time. Bight of rein should be on the off side. Hands are held above the withers at a height best suited to the animal with knuckles 30 degrees inside the vertical, hands slightly apart and making a straight line from horse's mouth to rider's elbow. Arms are held quiet and close to the sides.
6. Basic Position: Toes should be out at a slight angle best suited to rider's conformation, ankles flexed in, heels down, and calf of leg in contact with animal and slightly behind girth. Iron should be placed on ball of foot or horse with an even pressure on width of sole and center of the iron. The seat is erect and should appear comfortable and balanced. The rider's back is straight but relaxed, the shoulders square and head up. To mount, rider should take up reins in left hand and place hand on withers. Grasp stirrup leather with right hand and insert left foot in stirrup and mount with an easy, smooth motion up and over the animal settling in the saddle. To dismount, the rider may either step down or slide down. Riders in the 7th grade and under shall not be asked to mount and dismount. Judges may ask riders to ride in a "two point position" with contact on inside calf and thigh only with the horse (no seat contact).
7. Excessive kicking and spurring, losing contact with stirrups (unless asked by judge to drop irons), or failure to post on the correct diagonal is severely penalized.

## **HUNT SEAT EQUITATION OVER FENCES**

### **Purpose**

The Hunt Seat Equitation Over Fences class provides an opportunity for the 4-H member to display his or her ability as a rider over a course of hunter type fences. Equitation is to be evaluated as the combined performance of the animal and rider. The 4-H member is judged on his or her ability to maneuver a horse smoothly through a course of jumps with even striding. Judges emphasize safe jumping and fault breaks in rhythm of striding caused by jumping from a spot too close or too far away from the fence, or jumping too high.

### **Tack and Attire**

1. Refer to Hunter type tack and attire.
2. Optional: Standing Martingale ONLY, protective leg wraps or boots.
3. Prohibited: Draw reins, rubber reins.

### **Class Procedures and Guidelines**

1. The rider is judged over a course of at least eight jumps over a minimum of four different obstacles as determined by the show management. Fences should be hunter type fences. For types of fences, distances, possible courses, disobediences, etc., refer to Hunter Over Fences.

2. Obstacles should be 2 feet in height or 3 feet in height. Exhibitors should enter the height most appropriate for the skill level of the horse/rider combination, regardless of animal height.
  - a. Note: This is the maximum height. Show management should adjust show heights to fit the skill level of their exhibitors, including creating a crossrail class.
3. Exhibitor should be given time to walk the course without horse before the class.
4. Except for refusals, jumping faults of the animal are not to be considered unless the fault is the result of the rider's ability.
5. Any or all contestants may be asked to perform further tests over fences or on the flat at the discretion of the judge.
6. The rider is to be judged on his/her basic position in the saddle; hand, seat, and foot positions; his/her ability to control and show the animal; and the suitability of the animal to the rider. The performance is not to be considered more important than the rider's method to obtain performance.
7. Hand Position: Should be light and educated and held in any easy position. There should be light contact with animal's mouth. The method of holding reins is optional, except that both hands shall be used and all reins must be picked up at one time. Bight of rein should be on the off side. Hands are held above the withers at a height best suited to the animal. Arms are held quiet and close to the sides.
8. Basic Position: Toes should be out at a slight angle best suited to rider's conformation, ankles flexed in, heels down, and calf of leg in contact with animal and slightly behind girth. Iron should be placed on ball of foot or home with an even pressure on width of sole and center of the iron. The seat is erect and should appear comfortable and balanced. The rider's back is straight but relaxed, the shoulders square and head up.

### **Scoring**

- 90s - Great position - no jumping faults
- 80s - Excellent position - no jumping faults
- 70s - Good position - minor jumping faults
- 60s - Fair position - minor jumping faults
- 50s - Bad position - minor jumping faults
- 40s - Major jumping faults

### **Faults**

Minor Faults: propping, not centered to jump, wrong lead, riding behind the motion legs forward

Major Faults: Losing stirrup, rough hands knockdown, disobediences (including runouts and refusals), breaking gait

### **Disqualifications**

1. Three cumulative refusals on course.
2. Failing to complete course or being off course.
3. Jumping an obstacle before it is reset.

## **HUNTER UNDER SADDLE**

### **Purpose**

Hunters Under Saddle should be suitable to purpose. The animal should be sensible and well-mannered, providing a quiet and comfortable ride. The animal should move with impulsion and the ability to cover ground as in a hunt field. The frame should be appropriate for the breed or type, with stock type horses moving in a relatively low frame, and non-stock type horses having a relatively higher frame.

### **Tack and Attire**

1. Refer to Hunter type tack and attire.
2. Prohibited: Any type martingale, tie downs, draw reins, rubber reins, protective leg wraps or boots.

### **Class Procedures and Guidelines**

1. Entry is worked at a walk, trot, and canter, both directions of the ring. If asked to back, animal must back easily and stand quietly.
2. Class is to enter ring, turning to right and proceeding in a counterclockwise direction.
3. While working on the rail, the order to reverse should be executed by turning to the inside (away from the rail). The exhibitor may be asked to reverse at the walk or trot at the discretion of the judge, but shall not be asked to reverse at the canter.
4. A Hunter should work with light mouth contact without undue restraint.
5. The animal's response to the rider and free movement is emphasized in judging.
6. Rider shall not be required to dismount except in the event the judge wishes to check equipment.
7. Judge may ask for additional work of the same nature from any animal.
8. Judge is not to ask for work other than listed previously.
9. Entry shall be penalized for being on the wrong lead, but not necessarily disqualified. Excessive speed or slowness, head too high or poll below withers, being behind the vertical, breaking gait, appearing dull or lethargic, are to be penalized. Quick, short strides should be penalized.
10. A judge may ask for extended gaits.

## **SHOW JUMPING**

### **Purpose**

The show jumping class is designed to test the rider's ability to maneuver their mount over obstacles in a clean, efficient, and safe manner. Performance is scored mathematically.

### **Tack and Attire**

1. Refer to Hunter type tack and attire.
2. Optional: Any type martingale, tie down, rubber reins, protective leg wraps, boots, or dropped or figure eight nose band.



## **Class Procedures and Guidelines**

1. The animal is to be scored over a designed course determined by the show management. (See Scoring Table).
2. The course must have a minimum of four different obstacles, and the animal must make at least eight jumping efforts with at least one change of direction.
3. Possible obstacles might include brush, in and out, box, vertical rails, oxer, coop, crossbar, gate, picket type gates with a pole over them, etc. A triple bar, poles less than 8 feet in length, poles less than 4 inches in diameter, bales of hay or straw, tires, and hog backs are not to be used. Ground rails and wings are recommended for each fence. Fences shall either be made of wood or purchased from a commercial jump company. PVC rails and standards are allowed only if they are purchased from a commercial supplier and meet current safety standards.
4. Obstacles should be a maximum of 2 feet in height for novice skill level and 2 feet, 9 inches to 3 feet for advanced skill level. The primary concern in Hunter Over Fences Classes is to provide a safe environment for youth to exhibit their jumping skills. County shows are encouraged to offer classes at lower heights or crossrails appropriate to the skills and experiences of the members.
5. The distance between elements of an in-and-out obstacle should be set at 24 feet.
6. The starting mark should be at least 12 feet before the first obstacle and at least 24 feet beyond the last obstacle.
7. Show management must provide at least one practice jump in the warm-up arena and exhibitors (without horses) should be permitted to walk the course.
8. The course must be posted a minimum of one hour in advance of class by show management. For possible example courses, refer to Hunter Over Fences. The show manager should determine who will design the course, and provide the course diagram, prior to the show.

## **Scoring**

1. Scoring starts when horse passes the starting mark and ends when animal passes the finish mark.
2. If the animal makes two faults at one time at an obstacle, only the major fault on the top element is scored.
3. Only major faults (knock downs and disobediences) are scored.
  - a. Touches don't count.
4. When an obstacle contains more than one element, faults are scored on each.
5. In case of a refusal or run out on an obstacle that contains more than one jump or element, the entry must jump all elements of that obstacle.

## **Scoring Table**

1. 4 Point Faults - Knocking down obstacle, any portion of obstacle, timer, or cones by any part of animal and rider.
2. 3 Point Fault - First disobedience (refusal, run out, or bolting off course).

3. 6 Point Fault - Second cumulative disobedience (anywhere on course).
4. Elimination:
  - a. Third cumulative disobedience (anywhere on course)
  - b. Animal bolting from ring, mounted or not
  - c. Failing to complete course, off course
  - d. Jumping obstacle before reset
  - e. Falling of animal or rider
  - f. Failure of entry to cross starting line within one minute of an audible signal

### **Jump Offs**

1. When a jump off is required, the winner is decided on time only when jumping faults are equal.
  - a. Animals with jumping faults shall execute the jump off at the same fence height as the initial round.
  - b. The jump off is scored on jumping faults (including disobediences, falls, and knockdowns) and time.
  - c. Horses disqualified in the jump off are placed lowest among horses in the jump off. Ties shall be broken by the judge flipping a coin.

### **Disqualifications**

1. Three cumulative refusals on course.
2. Failing to complete course or being off course.
3. Jumping an obstacle before it is reset.

### **SHOW JUMPING-IN-HAND**

*(adapted from AMHR rulebook, 2019)*

#### **Purpose**

The jumpers in hand class is designed to test the ability of the exhibitor to maneuver their miniature horse over obstacles in a clean, efficient, and safe manner. Performance is scored mathematically, and participation is limited to miniature horses (38 inches and under).

#### **Tack and Attire**

1. Refer to Hunter-type tack and attire.
2. Horses to be shown in a halter with appropriate lead, chain on lead permitted under the chin of the horse.
3. Jumpers may show with braided manes and tails in the manner of their larger counterparts.
4. Whip may be carried.
5. Optional: Protective leg wraps or boots.

#### **Class Procedure and Guidelines**

1. Horses must be 3 years old or older.
2. Exhibitors not permitted to go over jumps.
3. Jumpers are scored mathematically on accumulated faults only unless there is a tie, in which case there will be a jump off (described on the next page).

## **Course**

1. There is a minimum of four fences and a maximum of six fences.
2. All jumps must have a ground pole.
3. Jump standards may not be taller than 40 inches.
4. No wings or additions are allowed outside the jump standards.
5. All jumps must be collapsible.
6. Jumps should be of attractive design but constructed of a material that does not cause danger to the horse. Obstacles must simulate those found in hunting, such as natural post and rail, brush, stone wall, white board gate, hedge, oxer, etc.

## **Course criteria**

1. The jumps can range in height from 12 to 24 inches. (In the jump off this changes to a minimum of 12 inches to a maximum of 30 inches.) All jumps must be at least 5 feet in width, no wider than 6 feet, with a minimum of 20 feet between jumps, with the exception of an in and out.
2. The distance between the two jumps of an in and out jump should be 10–12 feet. An in and out jump should never be the first jump in the course.
3. An in and out jump is considered one obstacle and scored as such. Refusal of one element of an in and out jump requires retaking both elements.

## **Faults**

1. Knockdowns: An obstacle is considered knocked down when in jumping an obstacle, a horse or handler, by contact, lowers the established height of the fence in any way – 4 faults.
2. Refusals: Stopping at an obstacle without knocking it down and without backing, followed by jumping from a standstill is not penalized. However, if the halt continues, or if the horse backs even a single step, side steps, or circles to retake the fence, a refusal is incurred:  
1st refusal      4 faults  
2nd refusal      4 faults  
3rd refusal      Disqualification
3. Circling: Any form of circle or circles whereby the horse crosses its original track between two consecutive obstacles, stops advancing toward the next obstacle, or turns away from the next obstacle, except to retake an obstacle after a disobedience. Crossing your own path (i.e., circling between fences, not retaking a fence from a refusal) – 3 faults.

## **Jump Offs/Breaking Ties**

1. When a jump off is required, the winner is decided on time only when jumping faults are equal.
2. The jump off is held over the original course. Only two jumps in the jump off are raised. The height of the jumps shall be increased not less than 1 inch and not more than 6 inches in height.
3. The jump off is scored on jumping faults (including disobediences, falls, and knockdowns) and time.

4. The jump off is timed, and the horse that has the fastest time and the fewest faults in the jump-off round is declared the winner. Horses disqualified in the jump off are placed lowest among horses in the jump off. Ties shall be broken by a judge flipping a coin.

### **Disqualifications**

1. Three cumulative refusals on course.
2. Failing to complete the course, or being off course.
3. Jumping of an obstacle before it is reset.
4. Fall of horse and/or exhibitor.

### **ENGLISH SADDLE TYPE TACK AND ATTIRE**

#### **English Saddle Tack - Halter and Showmanship**

1. The animal is to be shown in a halter or a bridle, which may be decorated.
2. The halter may be of leather, nylon, or rope, or may be a specialized breed show halter adjusted to fit properly with a throat latch strap. The lead strap or rope may be equipped with a chain. If a chain is used, it may be run through the rings of the halter in a manner that gives the exhibitor the most control of the animal, but in no case may the chain be through the animal's mouth.
3. The bridle must be a Pelham (one mouthpiece with two sets of reins), a full bridle (two sets of reins with separate bits and cheek pieces), or a Walking Horse bridle, all as described below. If the bridle is equipped with two reins, the snaffle rein is on the withers and the animal is led with the curb rein.
4. Optional: Whip, additional hair in horse's tail.
5. Prohibited: Dropped nosebands, leg chains or boots, hunter braided mane and tail (braids appropriate to breed are acceptable).

#### **English Saddle Tack - Performance**

1. Saddle must be flat English style, and may be cutback. Saddle must fit both animal and rider.
2. The bridle must be English type with plain or decorative browband and regular cavesson noseband. It may be a Pelham (two sets of reins), a full bridle (two sets of reins with separate bits and cheek pieces), or a Walking Horse bridle with curb bit and one set of reins. The curb chain must be at least 1/2-inch wide and lay flat against the animal's jaw. See page 33 for illustration of acceptable curbs.
3. Optional: Whip; saddle pad; additional hair in horse's tail.
4. Prohibited: Martingale or tiedown, dropped nosebands, leg chains or boots.
5. Refer to Gaited English Pleasure for class specific guidelines

#### **English Saddle Attire**

1. Minimum requirements are tailored long pants, a long-sleeved shirt or blouse with a tie, and Jodhpur boots. If a coat is worn, a short-sleeved shirt or blouse is permitted. A suitable coat is recommended. A traditional saddle suit with matching jacket and pants is preferred, especially in

equitation and showmanship. Hair must be restrained.

Refer to page 4 for the description of the required protective headgear. Judges must not discriminate against the use of protective vests by 4-H members in any class.

2. Optional: Gloves, approved protective vest; un-roweled spurs in performance classes, derby hat in halter classes.
3. Prohibited: Spurs in halter and showmanship classes; roweled spurs at any time.

## **SADDLE SEAT EQUITATION**

### **Purpose**

The Saddle Seat Equitation class provides an opportunity for the 4-H member to display his or her ability as a rider, i.e., the seat, hand, leg position and ability to control and show the mount. Saddle Seat Equitation is to be evaluated as the combined performance of the animal and rider.

### **Tack and Attire**

1. Refer to Saddle type tack and attire.

### **Class Procedures and Guidelines**

1. All riders are required to execute any appropriate test necessary to judge the riding ability of the rider, prior to the rail work.
2. Selected or all riders must be worked at a walk, trot, or equivalent breed gait, and canter at least one direction of the ring. Extended gaits may be asked for. The class may, at the judge's discretion, be asked to back.
3. While working on the rail, the order to reverse may be executed by turning either toward or away from the rail and may only be done from the walk, trot, or appropriate breed gait. Animals must be brought to a walk between all gaits.
4. The rider is judged on his/her basic positions in the saddle and hand, seat, and foot positions.
5. Hand Position: Should be light and educated and held in any easy position. Two reins are properly held in each hand with the snaffle rein outside the little finger. The arms are held quiet and close to the rider's side. The hands are held above the withers at a height best suited to the animal. Forearms and reins should form a line from the exhibitor's elbow to the animal's mouth.
6. Basic Position: The ball of the foot should be on the stirrup with heels lower than the toes, feet nearly parallel, and the stirrups slanted slightly outward. The seat should be erect and appear comfortable and balanced.
7. The rider's back should be straight but relaxed, the shoulders square and the head up. The rider's knee and thigh should have definite contact with the saddle.
8. Excessive kicking or spurring, losing contact with stirrups (unless asked by judge to drop irons), or failure to post on the correct diagonal is penalized.

## **SADDLE SEAT PLEASURE**

### **Purpose**

Saddle Seat Pleasure provides the 4-H member an opportunity to exhibit animals with plates only or with weighted shoes and pads. The animal is a well-mannered, free-moving, animated individual that provides a pleasant ride.

### **Tack and Attire**

1. Refer to Saddle type tack and attire.

### **Class Procedures and Guidelines**

1. Conformation is not to be considered in judging of this class.
2. Transition of gaits is to be performed smoothly with light rein and light mouth contact. Animals must be brought to a walk between all gaits.
3. Saddle Seat Pleasure is judged on performance, manners, and suitability at the walk, trot (equivalent breed gait), and canter, both ways of the ring.
4. If asked to back, animal must stand quietly and back readily.
5. Animal should display style and attractive carriage of head and tail.
6. An animated but controlled manner is desired.
7. Walk: Brisk, true, flat-footed, and ground-covering.
8. Trot (equivalent breed gait): Brisk, cadenced, easy, and balanced. Rider should post to a trot but not to the equivalent breed gait or rack.
9. Canter: Smooth, unhurried, collected, and straight on both leads.
10. Extended gaits may be asked for.
11. Extreme speed, slowness, breaking gait, or incorrect leads are penalized.
12. If Saddle Seat Pleasure and Gaited Saddle Seat Pleasure classes are offered at the same show, horses trotting in gaited classes, or showing at the alternate gait in Saddle Seat Pleasure, should be judged as not performing one of the required class gaits.

## **GAITED ENGLISH PLEASURE**

### **Purpose**

Gaited English Pleasure provides the 4-H member an opportunity to exhibit animals with plates only or with weighted shoes and pads. The animal is a well-mannered, free-moving, animated individual that provides a pleasant ride at a walk, slow gait, and fast gait. Show management may divide classes by shoeing criteria. Horses should not exceed the "lite shod" guidelines of their breed.

### **Tack and Attire**

1. Refer to Saddle type tack and attire, or appropriate breed.
2. Roweled spurs are allowed.
3. Breast collars, girths and browbands may be embellished with colored leather or vinyl accents.
4. Braids are allowed if breed appropriate. Prohibited: Western bridle.

## **Class Procedures and Guidelines**

1. Conformation is not to be considered in judging of this class.
2. Transition of gaits is to be performed smoothly with light rein and light mouth contact.
3. Gaited English Pleasure is judged on performance, manners, and suitability at the walk, slow gait, and fast gait, both ways of the ring.
4. If asked to back, animal must stand quietly and back readily.
5. Animal should display style and attractive carriage of head and tail.
6. An animated but controlled manner is desired.
7. Walk: Brisk, true, flat-footed, and ground covering.
8. Slow breed gait: Brisk, cadenced, easy, and balanced. Rider should not post breed gait.
9. Fast breed gait can be a canter or faster four beat gait. Show management may divide classes into canter/no canter divisions.
10. Extended gaits may be asked for.
11. Extreme speed, slowness, trotting, breaking gait, or incorrect leads are penalized.
12. If Saddle Seat Pleasure and Gaited Saddle Seat Pleasure classes are offered at the same show, horses trotting in gaited classes, or showing at the alternate gait in Saddle Seat Pleasure, should be judged as not performing one of the required class gaits.

## **PLEASURE DRIVING**

### **Purpose**

The Pleasure Driving class demonstrates the animal's ability to provide the driver with a pleasant drive at a walk, working trot, and a strong trot. The animal must be well-mannered, easy to control, and safe for a novice to drive.

### **Tack**

1. The type of harness is optional but must fit the animal and be a complete harness. A snaffle bit with straight or jointed mouthpiece is preferred. A single animal must be shown hitched to a two- or four-wheeled vehicle with a basket guard and suitable to the animal. It is essential that all equipment be in sound condition.
2. Optional: Running martingale, breeching, thimbles, blinders, over check or side check, whip, curb bits meeting the judge's approval.
3. Prohibited: Tail set, spoon crupper, handholds, noisemakers, and protective leg wraps or boots.

### **Attire**

1. Exhibitor shall be neatly attired. Western, Hunter, or Saddle Seat attire are acceptable, as long as this attire is consistent with the style of vehicle. Ladies may wear long-sleeved dresses. Ladies attired in short dresses are required to have a lap robe. All drivers and attendants must wear ASTM-approved helmets when in the vehicle. Exhibitors must wear

- closed-toed shoes or boots. Exhibitor's clothing should not interfere with their ability to leave the vehicle quickly.
2. The exhibitor number must be worn/or placed in an unobstructed manner.

### **Class Procedures and Guidelines**

1. This class can be offered for single animals. (Counties may choose to offer this class for pairs/teams, but only single animals are exhibited at the Indiana State Fair.) When possible, miniature, pony, light horse, and draft classes should be offered separately.
2. The animal is to be judged on manners, quality, and performance.
3. The animal is to be shown at a flat-footed walk, a normal trot, and an extended trot, both ways of the ring. Change of direction is to be executed at the walk diagonally across the arena and only as directed by the ring steward.
4. The animal is to stand quietly and back readily.
5. Only the 4-H exhibitor may ride in the vehicle unless, for safety purposes, show management approves the accompaniment (not assisting) by one groom capable of providing assistance if necessary.
6. Header/Groom may be a 4-H member or an adult appropriately attired. Refer to appropriate tack and attire sections.
7. Excessive speed and breaking gait are penalized.

### **Disqualifications**

1. Header entering ring before line up.
2. Falling of animal or driver.

## **REINSMANSHIP**

### **Purpose**

The Reinsmanship class emphasizes the driver's effective handling of lines, whip, control, posture, and overall appearance while performing at walk, trot, and extended trot and requested pattern.

### **Tack and Attire**

1. See Pleasure Driving tack and attire.

### **Class Procedures and Guidelines**

1. This class can be offered for single animals. (Counties may choose to offer this class for pairs/teams, but only single animals are exhibited at the Indiana State Fair.) When possible, miniature, pony, light horse, and draft classes should be offered separately.
2. The animal is to be shown at a walk, a normal trot, and an extended trot, both ways of the ring. Change of direction is to be executed at the walk diagonally across the arena and only as directed by the ring steward.
3. The animal is to stand quietly and back readily.
4. Only the 4-H exhibitor may ride in the vehicle unless, for safety purposes, show management approves the



accompaniment (not assisting) by one groom capable of providing assistance if necessary.

5. Headers are permitted when class is lined up.
6. Individual patterns may be called for.

### **Disqualification**

1. Header entering ring before line up.

## **OBSTACLE DRIVING**

### **Purpose**

To provide the 4-H member an opportunity to display his or her ability to navigate their driven entry through a course of obstacles and task similar to a trail pattern.

### **Tack and Attire**

See Pleasure Driving.

### **Class Procedures and Guidelines**

1. This class can be offered for single animals. (Counties may choose to offer pair/team classes; however, those classes are not offered at State Fair.) When possible, miniature, pony, light horse, and draft classes should be offered separately. Counties may also consider offering this as a ground-driven class.
2. The judge assigns a point value to each task, and points are added to or subtracted from this score based on the horse's performance through the task. Points may be added or subtracted from a horse's total score on the tasks based on his attitude, manners, style, and way of going.
3. Manner of horse's way of going should demonstrate the general utility of the driving horse in everyday working situations.
4. Credit is given to horses that negotiate, in a continuous motion, the tasks cleanly, smoothly, and alertly with style, in prompt response to the driver's cues. Excessive hesitation at a task shall be penalized. The scoring, faults, and obstacles are evaluated as in a trail class.

### **Course Requirements**

1. Number of Tasks. The course includes a minimum of six and a maximum of eight tasks.
2. Setting up Tasks. Care must be exercised to avoid setting up any of these tasks in a manner that may be hazardous to the horse or driver. All tasks not combined shall be a minimum of 15 feet apart.
3. Course Design to Demonstrate Gaits. The course shall be designed to require each horse to demonstrate walk, normal trot, and extended trot.

### **Obstacles/ Tasks**

1. Refer to trail class for obstacles.
2. Commonly used are back through, barrels, poles or pylons, box, bridge, figure eight(s), L-obstacle(s), and mailbox. See the American Paint Horse Handbook for details.

## **WESTERN TACK AND ATTIRE**

### **Tack - Western Halter and Showmanship**

1. The animal is to be shown in a halter made of leather, nylon, or rope, adjusted to fit properly. A lead strap or rope with or without chain is used. If the lead is equipped with a chain, the chain may be run through the rings of the halter in a manner that gives the exhibitor the most control of the animal, but may not be through the animal's mouth. Specialty breed halters that meet this description, including Arabian halters, are allowed.
2. Silver tack may be used but is not given preference over clean working equipment.
3. Optional: Additional hair in horse's tail.
4. Prohibited: Whip or crop of any kind; bridle or hackamore; English type show halter.

### **Tack - Western Performance**

1. Saddle must be western style, and must fit both animal and rider. Stirrups may not be attached to each other or to other equipment. They may not be attached to the saddle by any means except the stirrup leathers. Bridle must be western style, either with browband, split ear, or formed ear. Silver tack may be used but is not given preference over clean working equipment.
2. Any animal may be shown in a western curb bit that has a solid or broken mouthpiece (2 or 3 pieces) and shanks, and acts with leverage. The mouthpiece must be a minimum of 3/8 inch in diameter measured 1 inch from the shank. A maximum length of the shank shall be 8 1/2 inches. The maximum height of the port shall be 3 1/2 inches. A curb strap or chain must be used, and must be at least 1/2 inch wide and lay flat against the animal's jaw. See illustration below of acceptable curb straps and legal and illegal bits.
3. Split or romal reins may be used with a curb bit. When split reins are used, the reins are held in one hand, and hand may not be changed. (See exception for Trail.) One finger between the reins is permitted, and the bight of the reins falls on the same side of the animal as the hand holding the reins. Romal reins are closed reins with an extension of braided material attached. Romal reins are held in one hand with hand around the reins and no finger permitted between the reins. The extension is carried in the free hand with at least a 16-inch spacing between the reining hand and the hand holding the romal extension.
4. Animals 5 years of age and younger may be shown in a snaffle bit or bosal (hackamore). Snaffle bits (no shanks) must have a straight or broken (2 or 3 pieces), smooth (not sharp), round mouthpiece with no leverage applied; and may have D-ring, O-ring, or eggbutt cheekpieces no more than 4 inches in diameter. An optional loose chin strap of leather or nylon only is permissible, and must be attached below the reins. Split reins must be used with two hands on the reins. See illustration of acceptable snaffle bits and hand position when using a snaffle or bosal. Bosals may be of braided rawhide or leather, with no metal under the jaw or on the noseband.

There must be a minimum of one finger-space between the bosal and the animal's nose. See illustration of bosal and acceptable hand positions. The mouthpiece should be round, oval or egg-shaped, smooth and unwrapped metal, but must be a minimum of 3/8 inch in diameter, measured 1 inch in from the cheek piece.

5. For color guard and speed events *only*, mechanical hackamores are permitted in addition to that listed above. Closed reins may be used.
6. Optional in All Western Classes: Breast strap; hobbles on saddle when romal is used; covered stirrups or tapaderos; additional hair in horse's tail.
7. Prohibited in All Western Classes:
  - a. Any equipment or bit that judge, show steward, or show officials consider to be unduly severe or unsafe.
  - b. Any bit with cathedral or donut mouthpieces, rough, sharp materials such as screw mouthpieces, or mechanically altered bits are illegal and are cause for disqualification.
  - c. Metal over bridge of horse's nose or poll, no matter how padded or wrapped.
8. Special Note: Additional optional and prohibited tack pertaining to specific classes is noted in rules for that class.

#### Acceptable Chain Curb Straps

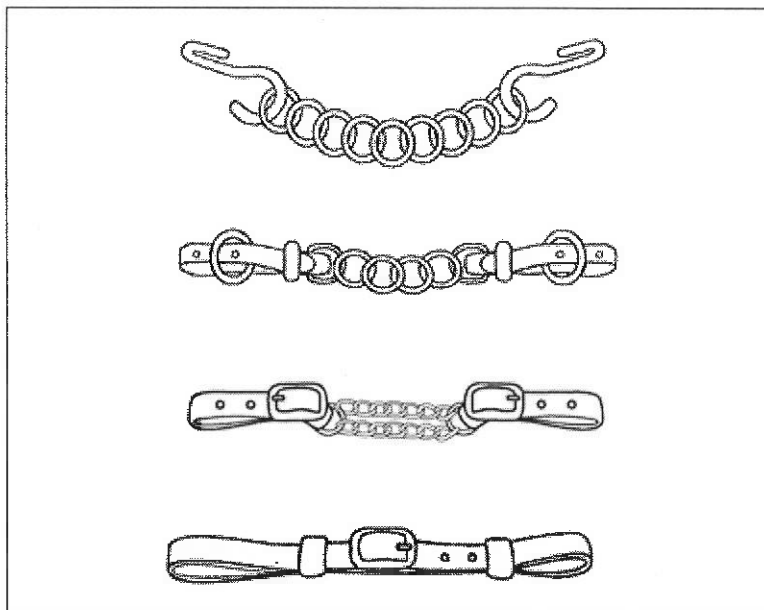

#### Western Bits

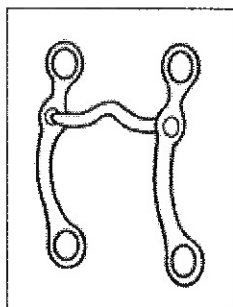

#### Illegal Western Bits

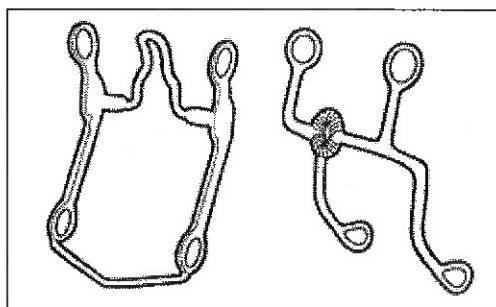

## Western Snaffle Bits and Bosal

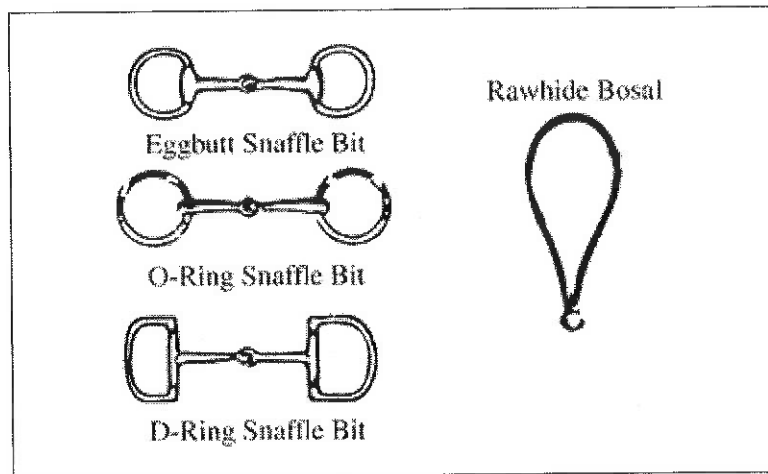

## Acceptable Hand Positions when using a Western Snaffle Bit or Bosal

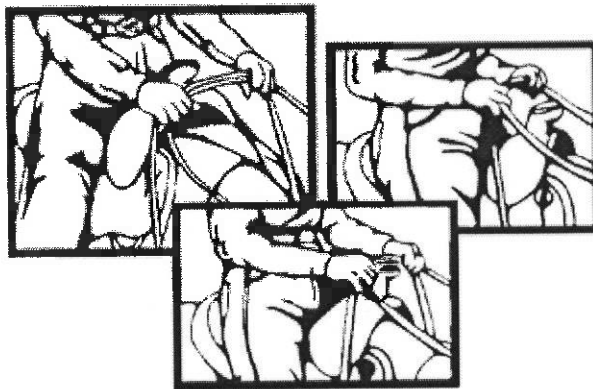

*Florida 4-H has permitted Indiana 4-H to reference its helpful explanation of bit types and correct hand positions. See <https://animal.ifas.ufl.edu/youth/horse/documents/BitRules.pdf>. This resource is for information only and does not supersede the criteria for acceptable bits in this handbook. Something that is legal in Florida may not be legal in Indiana.*

## Western Attire

1. Minimum requirements are western style long pants, long-sleeved shirt with collar (band, standup, tuxedo, etc.), and western boots with a heel. ASTM and/or SEI standard F1163 or above approved protective headgear is required in all Western Classes when the exhibitor is mounted. See page 4 for complete description of approved headgear. Judges must not discriminate against the use of protective vests by 4-H members in any class, or wearing helmets in halter and showmanship.
2. Optional: Coats, vest, jackets, gloves, and protective vests in all classes; chaps and spurs in performance classes.
3. Prohibited: Ball caps, riding sneakers, or hats other than protective headgear. Chaps or spurs in halter and showmanship classes.

4. Special Note: Additional optional and prohibited attire pertaining to specific classes is noted in the rules for that class.
5. Western hat or helmet is required in halter/showmanship.

## **WESTERN HORSEMANSHIP**

### **Purpose**

Horsemanship competition provides the 4-H member an opportunity to display his or her ability as a rider, i.e., the seat, hand, leg position, and ability to control and show the mount. Western Horsemanship is evaluated as the combined performance of the animal and rider.

### **Tack and Attire**

1. Refer to Western tack and attire.
2. Optional: Protective leg wraps or boots.
3. Prohibited: Mechanical hackamore, draw reins, tie downs, any type martingale, cavesson noseband, crop, bat, and whip.

### **Class Procedures and Guidelines**

1. Entries must be asked to perform tests individually before the class does the rail work. Individual work should be in accordance with the age division's ability. The judge may ask for tests necessary to judge the extent of the rider's horsemanship.
2. Selected or all riders must be worked at a walk, jog (or equivalent breed gait), and lope, at least one direction of the ring after completing pattern work. The class may, at the judge's discretion, be asked to extend normal gaits, mount and dismount, and back animal.
3. Performance of the animal is not to be considered more important than the rider's method used to obtain performance.
4. Riders in the 7th grade and under shall not be requested to mount and dismount in horsemanship classes.
5. For rail work, the class is to proceed in a counterclockwise direction or at the direction indicated by the judge.
6. When asked to reverse while working on the rail, the rider should reverse toward the center of the ring. This must be done only at a walk or jog.
7. The rider should sit in the saddle with legs hanging straight and slight forward to stirrup. The stirrup should be short enough to allow heels to be lower than toes. Legs should maintain contact with animal, giving aids or cues to the horse. Feet may be placed full home in stirrup or ball of foot placed in stirrup. A rider should keep the back straight and shoulders even, and sit in a balanced, relaxed manner.
8. The arms should be held in a relaxed manner close to the body. When riding with a bit with shanks, two hands may not be used, and hands may not be changed. When riding with one hand on the reins, the position of the rider's free hand is optional, but it should indicate a relaxed (but not sloppy) attitude. When using a romal, the rider's off hand shall be around the romal with about 16 inches of slack. Reins should be carried so as to have light contact with the animal's

mouth, and at no time shall the reins be carried more than a slight hand movement from the animal's mouth. When using both hands with snaffle or bosal, refer to page 34 for proper hand positions.

9. While in motion the rider should sit the trot and not post. At the lope he/she should be close to the saddle. All movements of the animal should be governed by the use of imperceptible aids without exaggerated shifting of the rider's weight.
10. The exhibitor may not touch the horse or saddle with the free hand.
11. Excessive kicking or spurring, losing contact with stirrups (unless asked by judge to ride with feet out of stirrups), or striking the animal is penalized.

## **WESTERN PLEASURE**

### **Purpose**

A western pleasure animal is a sensible, alert, bright, easy moving, well-mannered mount that can provide a quiet, comfortable and pleasant ride at a walk, jog, and lope. Western pleasure competition is not to be confused with an equitation or horsemanship class in which the rider is judged. Type of animal is not considered in judging the class.

### **Tack and Attire**

1. Refer to Western tack and attire.
2. Prohibited: Mechanical hackamore, draw reins, tie downs, any type martingale, cavesson noseband, protective leg wraps or boots, crops, bats, whips.

### **Class Procedures and Guidelines**

1. Animals are shown at a walk, jog, and lope on a reasonably loose rein or light contact without undue restraint. Animals must back easily and stand quietly.
2. Animals work both ways of the ring at all three gaits, and are reversed to the inside (away from the rail). The judge may require entries to reverse at the walk or the jog, but never at a lope.
3. A judge may ask for additional work of the same nature from any animal.
4. A judge may ask for extended gaits. Rider shall not be required to dismount unless judge wishes to check equipment.
5. Entries are penalized for being on the wrong lead, excessive speed or slowness, breaking gait, appearing dull or lethargic, head too high, or the poll being lower than the withers.
6. The exhibitor may not touch the horse or saddle with the free hand.
7. When riding with a bit with shanks, two hands may not be used, and hands may not be changed.
8. If Western Pleasure and Gaited Western Pleasure classes are offered at the same show, horses trotting in gaited classes or showing at the alternate gait in Western Pleasure should be judged as not performing one of the required class gaits.

## **GAITED WESTERN PLEASURE**

### **Purpose**

A gaited western pleasure animal is a sensible, alert, bright, easy-moving, well-mannered mount that can provide a quiet, comfortable, and pleasant ride at a walk, slow gait, and fast gait. Western pleasure competition is not to be confused with an equitation or horsemanship class in which the rider is judged. Type of animal is not considered in judging the class.

### **Tack and Attire**

1. Refer to Western tack and attire.
2. Western split reins or romal reins are required; single reins are prohibited.
3. Prohibited: English bridles, Western bridles, with colored browbands, mechanical hackamore, draw reins, tie downs, any type martingale, cavesson noseband, protective leg wraps or boots, crops, bats, whips. Horses may not have braids in the mane.

### **Class Procedures and Guidelines**

1. Animals are shown at a walk, slow gait (running walk, show rack, etc.), and fast gait (lope or fast rack) on a reasonably loose rein or light contact without undue restraint. Animals must back easily and stand quietly.
2. Animals work both ways of the ring at all three gaits, and are reversed to the inside (away from the rail). The judge may require entries to reverse at the walk or slow gait, but never at a fast gait.
3. A judge may ask for additional work of the same nature from any animal.
4. A judge may ask for extended gaits. Rider shall not be required to dismount unless judge wishes to check equipment.
5. Entries are penalized for being on the wrong lead, excessive speed or slowness, breaking gait, appearing dull or lethargic, head too high, or the poll being lower than the withers.
6. The exhibitor may not touch the horse or saddle with the free hand.
7. When riding with a bit with shanks, two hands may be used when breed-appropriate.
8. If Western Pleasure and Gaited Western Pleasure classes are offered at the same show, horses trotting in gaited classes or showing at the alternate gait in Western Pleasure should be judged as not performing one of the required class gaits.

## **RANCH PLEASURE** (*rail class*)

### **Purpose**

A superior ranch riding horse has a free-flowing stride of reasonable length in keeping with his conformation and covering a reasonable amount of ground. Ideally he should have a balanced, flowing motion, while exhibiting correct gaits with proper cadence and rhythm. The quality of the movement and consistency of the gaits is a major consideration. He should have a bright expression with his ears alert. He should be mannerly

without the appearance of a dull, sullen, lethargic, drawn, or overly tired attitude. He should be shown on a reasonably loose rein but with light contact and control. He should be responsive yet smooth in transitions when called for. When asked to extend, he should move out with the same flowing motion. Maximum credit should be given to the horse that has a flowing stride, is balanced, and that gives the appearance of being willing, fit, alert, and a pleasure to ride while possessing great athletic ability and agility. This class is judged on the performance, athletic ability, condition, and conformation of the horse.

### **Tack and Attire**

1. Refer to Western Tack and Attire.
2. No hoof polish.
3. No braided or banded manes or tail extensions.
4. Trimming inside ears is discouraged.
5. Trimming bridle path is allowed, also trimming of fetlocks or excessive (long) facial hair.
6. Equipment with silver should not count over a good working outfit. Silver on bridles and saddles is discouraged.

### **Class Procedures and Guidelines**

1. Horses must work both ways of the ring at all three gaits to demonstrate their ability with different leads. At the option of the judge, horses may be asked to extend the walk and the jog, one or both ways of the ring. The extended jog is a definite two-beat lengthening of the stride, covering more ground. Cadence and balance with smoothness are more essential than speed. Passing is permissible and should not be penalized as long as the horse maintains a proper and even cadence and rhythm. Horses are required to back easily and stand quietly.
2. Horses are to be reversed to the inside (away from the rail). They may be required to reverse at the walk or jog at the discretion of the judge, but shall not be asked to reverse at the lope.
3. Horses are to be shown at a walk, jog, and lope on a reasonably loose rein or light contact without undue restraint. Judges at their discretion may also ask for an extended trot. Posting, or standing in the stirrups, is allowed in the extended trot.

### **Faults to be scored according to severity:**

1. Excessive speed (any gait).
2. Being on the wrong lead.
3. Breaking gait (including not walking when called for).
4. Excessive slowness in any gait, loss of forward momentum (resulting in an animated and/or artificial gait at the lope).
5. Failure to take the appropriate gait when called for. (During transitions, excessive delay is penalized.)
6. Over-flexing or straining neck in carriage so that the nose is behind the vertical.
7. Excessive nosing out.
8. Opening/gapping mouth excessively.
9. Stumbling.



10. Use of spur in front of the cinch.
11. Sullen, dull, lethargic, emaciated, drawn or overly tired appearance.
12. Quick, choppy or short-strided.
13. Overly canted at the lope (horses that lope with haunches in toward the center of arena).
14. Excessive head bobbing.
15. Excessive ringing of tail.

### **Credits**

1. Natural ground-covering gaits.
2. Consistency at all gaits.
3. Smooth upward and downward transitions.
4. Work on reasonably loose rein without excessive cueing to maintain moderate pace.
5. Athletic ability/agile.
6. Softness of horses' chin, poll, neck, shoulder, body, hip and through the whole body.

### **Disqualifications**

1. Grabbing the saddle horn or any other part of the saddle.
2. Illegal use of hands on reins.
3. Use of prohibited equipment.

## **RANCH RIDING** (*pattern class*)

### **Purpose**

The Ranch Riding horse should reflect the versatility, attitude, and movement of a working horse. The horse's performance should simulate a horse riding outside the confines of an arena and that of a working ranch horse. This class should show the horse's ability to work at a forward, working speed while under control by the rider. Light contact should be rewarded, and the horse does not have to be shown on a full drape of reins. The overall manners and responsiveness of the horse while performing the maneuver requirements, and the horse's quality of movement are the primary considerations.

### **Tack and Attire**

1. Refer to Western Tack and Attire.
2. No hoof polish.
3. No braided or banded manes or tail extensions.
4. Trimming inside ears is discouraged.
5. Trimming bridle path is allowed, also trimming of fetlocks or excessive (long) facial hair.
6. Equipment with silver should not count over a good working outfit. Silver on bridles and saddles is discouraged.

### **Class Procedures and Guidelines**

1. Each horse works individually, performing both required and optional maneuvers, and is scored on the basis of 0 to 100, with 70 denoting an average performance.
2. The required maneuvers include the walk, jog, and lope both directions; and the extended jog and lope at least one direction; as well as stops, turn to change directions, and back.

3. Three optional maneuvers may include a side pass, turns of 360 or more, change of lead (simple or flying), walk, jog, or lope over a pole(s).
4. The overall cadence and performance of the gaits should have an emphasis on forward movement, free-flowing, and ground covering for all gaits. Transitions should be performed where designated, with smoothness and responsiveness.
5. Riders may post, stand in the stirrups, or sit the extended jog.
6. One of the two patterns below must be used.
7. Failure to perform a required maneuver results in a horse placing below all other horses that perform all maneuvers

### Ranch Riding - Pattern 1

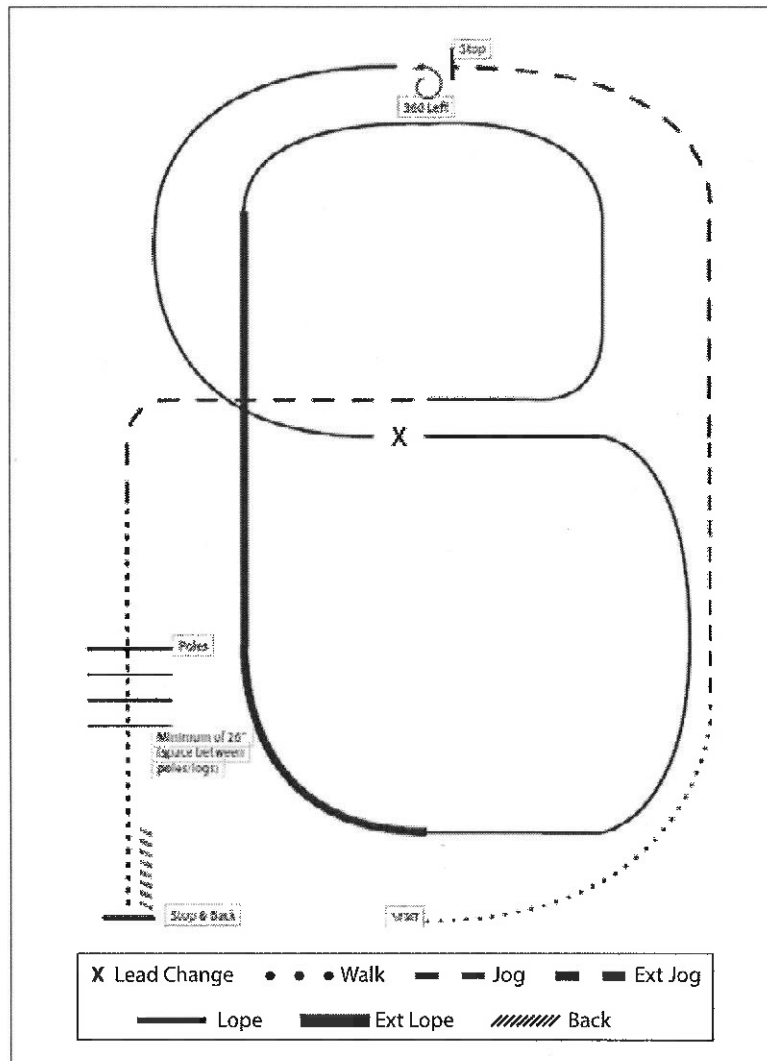

1. Walk
2. Jog
3. Extend the jog. At the top of the arena, stop
4. 360 turn to the left
5. Left lead half circle, lope to the center
6. Change leads (simple or flying)
7. Right lead half circle
8. Extended lope up the long side of the arena (right lead)
9. Collect back to a lope around the top of the arena and back to center
10. Break down to a jog
11. Walk over poles
12. Stop and back

## Ranch Riding - Pattern 2

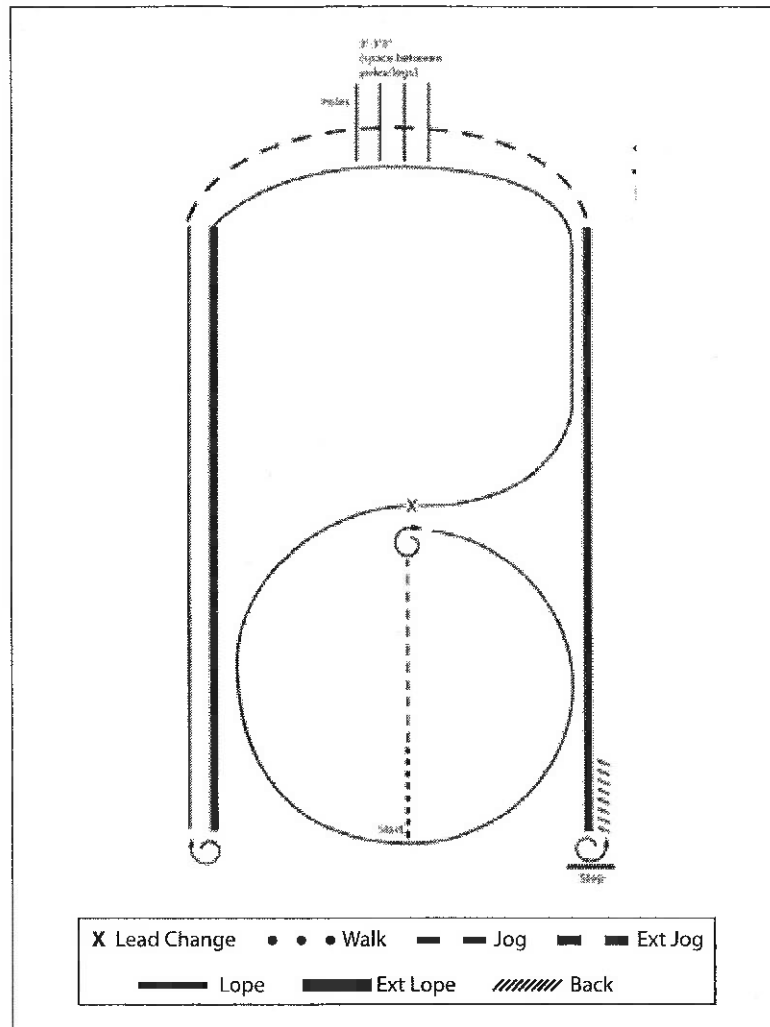

1. Walk
2. Jog
3. Stop, do one one-quarter turn to the right
4. Lope small circle on the right lead
5. Change leads, (simple or flying) lope left lead around end of the arena
6. Extend the lope on the left lead
7. Stop, do two one-half turns right
8. Lope straight on the right lead
9. Extend the jog around end of the arena across poles/logs
10. Extend lope on right lead
11. Stop, do two turns left
12. Back

### Scoring

1. Each maneuver receives a score that should be added or subtracted from 70 and is subject to a penalty that should be subtracted. Each maneuver is scored on the following basis, ranging from plus 1 1/2 to minus 1 1/2:
  - -1 1/2 extremely poor
  - -1 very poor
  - -1/2 poor
  - 0 correct
  - +1/2 good
  - +1 very good
  - +1 1/2 excellent

2. No specific penalties are incurred for nicks/hits on logs, but deduction may be made in maneuver score.
3. No specific penalties are incurred for over/under spins, but deduction may be made in maneuver score.

### **Penalties**

A contestant shall be penalized each time the following occur:

#### *1 point penalties*

- Too slow/per gait
- Over-bridled
- Out of frame
- Break of gait at walk or jog for two strides or less
- Split log at lope

#### *3 point penalties*

- Break of gait at walk or jog for more than two strides
- Break of gait at lope
- Wrong lead or out of lead
- Draped reins

#### *5 point penalties*

- Blatant disobedience (kick, bite, buck, rear, etc.)

#### *Placed below horses performing all maneuvers*

- Eliminates maneuver
- Incomplete maneuver

#### *Zero score*

- Illegal equipment including hoof black, braided or banded
- manes, or tail extensions
- Willfull abuse
- Major disobedience or schooling

## **VERSATILITY**

### **Purpose**

A Versatility horse should perform all four disciplines with willingness and correctness. The horse and rider show the difference in way of going between the Western Pleasure and Hunter Under Saddle disciplines, and transition easily from one discipline to the next.

### **Tack and Attire**

1. Refer to Western Tack and Attire, and Hunter Tack and Attire.
2. Tack and attire prohibited for each of the classes shown independently, are also prohibited in Versatility.

### **Class Procedures**

1. Horses perform in: Hunter Under Saddle (HUS), Western Horsemanship (WH), Western Pleasure (WP) and Barrel Racing (BR). All classes are judged according to the rules in this handbook.
2. Exhibitors in 4-H versatility must have two helpers who are 4-H members (they do not need to be from same county), and have 5 minutes to change their clothes and tack between HUS and WH.
3. Exhibitors are allowed 2 minutes to change bridles and add protective legwear between WP and BR.

4. Helpers must be safely attired in long pants/jeans, a shirt with a collar, and boots. They must wait in the designated area and not approach their rider until instructed to do so by the show officials.
5. Exhibitors must provide the device to transport tack. Any wheeled equipment that is powered only by the two helpers is allowed.

### **Disqualification**

1. All disqualifications listed in the class guidelines for each class (HUS, WH, WP, BR).
2. Beginning to change clothes before instructed by the show official.
3. Reckless behavior on the part of the rider, or the helpers, that may endanger themselves or others, at the discretion of the judge.
4. Failure to follow the class procedures in regard to helpers and tack transport device.

## **WESTERN RIDING**

### **Purpose**

Western Riding demonstrates an animal's athletic ability and handiness, enabling the rider to direct it through a variety of jobs on the farm or ranch. The animal is sensible, well-mannered, free and easy moving, and able to provide quiet, comfortable rides at a walk, trot (or equivalent breed gait), and lope. Western Riding is neither a stunt nor a race. Depending on the skill level of the riders, counties may consider offering Western Riding in two separate classes; Novice Western Riding (using novice pattern below); and Advanced Western Riding (using one of the other patterns below). Participants should not be allowed to cross-enter both classes, and only the Advanced version is offered at the State Fair 4-H Horse Show.

### **Tack and Attire**

1. Refer to Western tack and attire.
2. Optional: Skid boots, splint boots, protective leg wraps.
3. Prohibited: Mechanical hackamore, draw reins, tie down, any type martingale, cavesson noseband, crop, bat, and whip.

### **Class Procedures and Guidelines**

1. The animal is judged on quality of gaits, change of leads, response to the rider, manners, and disposition. Credit is given for and emphasis placed on smoothness, even cadence of gaits (starting and finishing pattern with the same cadence), and the animal's ability to change leads precisely and easily at the center point between markers.
  - a. Relaxed head carriage that shows response to the rider's hand(s) with moderate flexion at the poll.
  - b. Cross the log at the trot and the lope without breaking gait or radically changing stride.
  - c. Quiet mouth.

2. One of the following patterns and routines is used. Judge and exhibitors must adhere to it. Note: Novice Level pattern is **not** used at the Indiana State Fair.
  - a. The eight small circles represent markers (cones/pylons recommended). These should be separated by a uniform distance of not less than 30 feet nor more than 50 feet along the side with 5 cones/pylons. Those on the opposite side should be 60-100 feet apart. A marker must be on both ends of the log.
  - b. A solid log or pole should be used, a minimum of 8 feet in length (just high enough to break the animal's stride).
  - c. On completion, he/she should ride to the center of the pattern and back the animal as indicated by the pattern.
3. Counties may choose to allow more than four simple lead changes at their county shows.

**Pattern 1: Novice Western Riding**

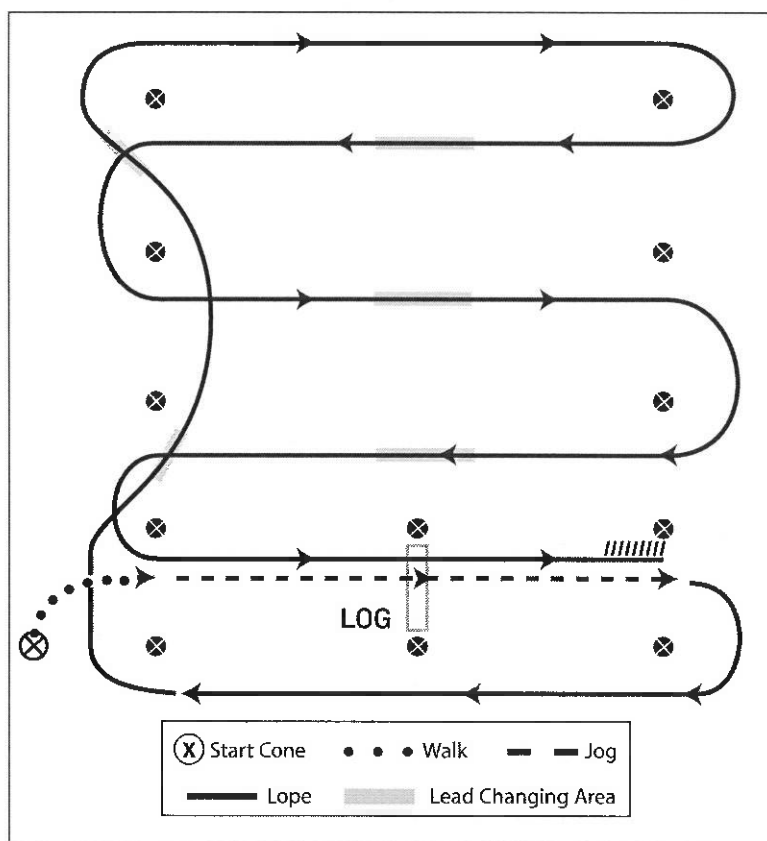

1. Walk, transition to jog, jog over log
2. Transition to right lead and lope around end
3. First line change
4. Second line change, lope around end of arena
5. First crossing change
6. Second crossing change
7. Third crossing change
8. Lope over log
9. Lope, stop and back

## Western Riding Pattern 2

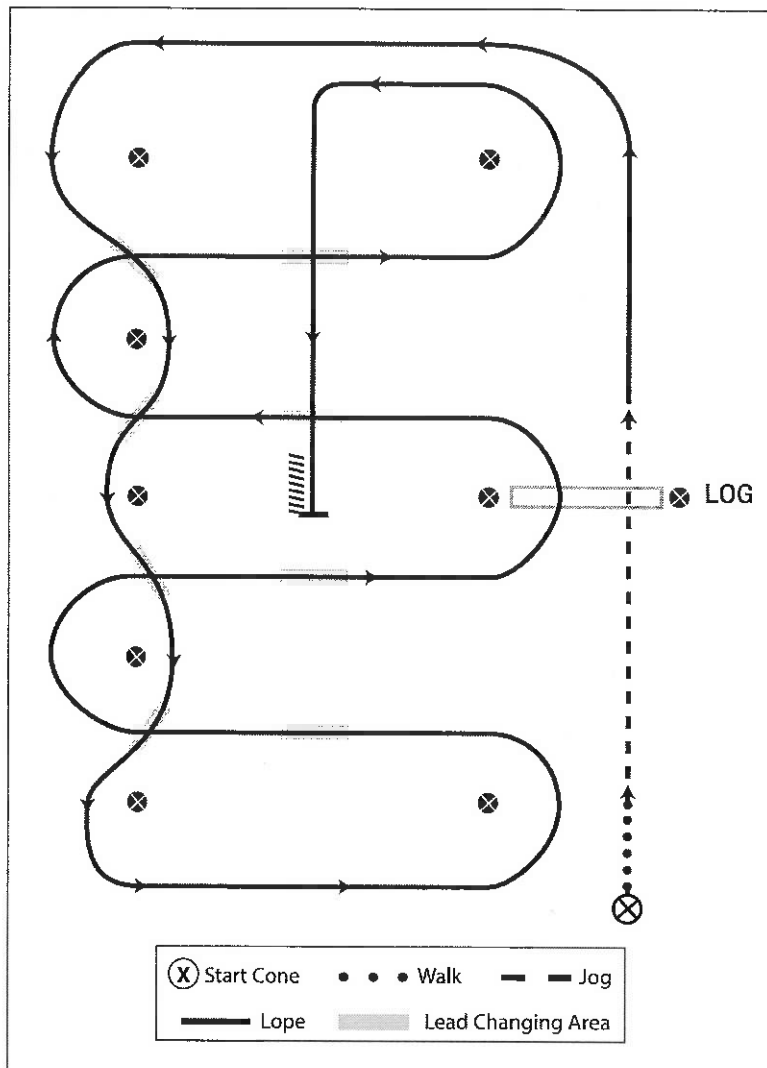

1. Walk at least 15 feet and jog over log
2. Transition to left lead and lope around end
3. First line change
4. Second line change
5. Third line change
6. Fourth line change lope around the end of arena
7. First crossing change
8. Second crossing change
9. Lope over log
10. Third crossing change
11. Fourth crossing change
12. Lope up the center, stop and back

## Western Riding Pattern 3

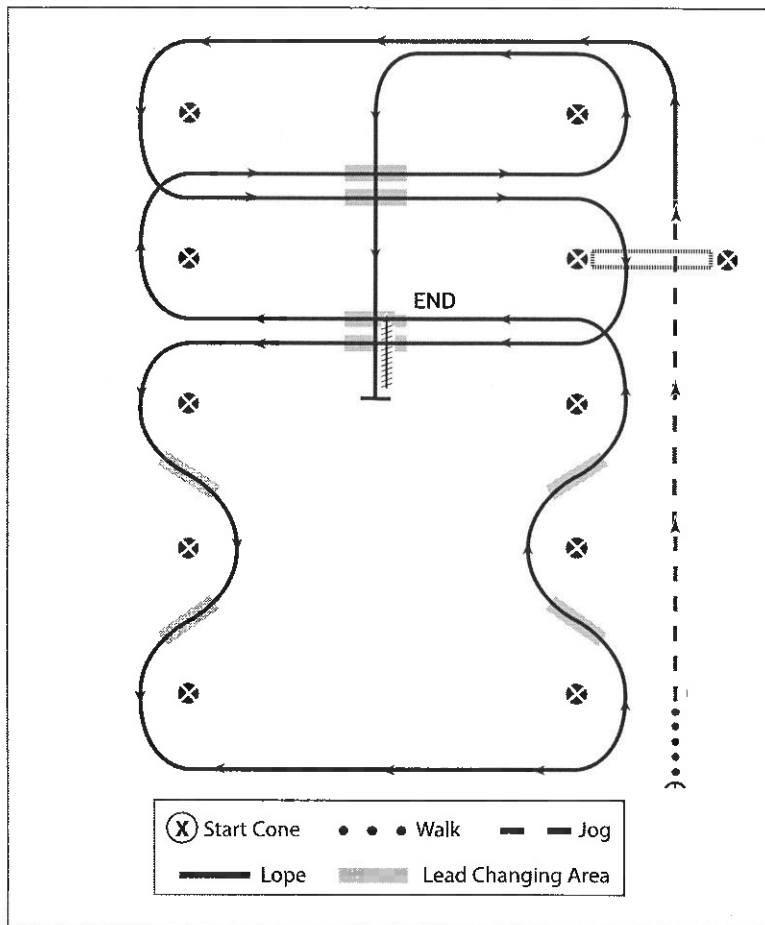

1. Walk halfway between markers, transition to jog, jog over log
2. Transition to the lope, on the left lead
3. First crossing change
4. Lope over log
5. Second crossing change
6. First line change
7. Second line change
8. Third line change
9. Fourth line change
10. Third crossing change
11. Fourth crossing change
12. Lope up the center, stop and back

### Scoring

Scoring is on a basis of 0-100 with 70 denoting an average performance. Scoring guidelines to be considered: points are added or subtracted from the maneuvers on the following basis, ranging from plus 1.5 to minus 1.5: -1.5 extremely poor, -1 very poor, -.5 poor, 0 average, +.5 good, +1 very good, +1.5 excellent. Maneuver scores are to be determined independently of penalty points.



## **Credits**

1. Changes of leads, hind and front simultaneously.
2. Change of lead near the center point of the lead change area.
3. Accurate and smooth pattern.
4. Even pace throughout.
5. Easy to guide and control with rein and leg.
6. Manners and disposition.
7. Conformation and fitness.

## **Faults to be judged in maneuver scores according to severity**

1. Opening mouth excessively.
2. Anticipating signals.
3. Stumbling.
4. Head carried too high.
5. Head carried too low (tip of ear below the withers).
6. Over-flexing or straining neck in head carriage so the nose is carried behind the vertical.
7. Excessive nosing out.

## **Penalties**

A contestant shall be penalized each time the following occur:

### *5 points*

1. Out of lead beyond the next designated change area. (*Note: failures to change, including cross-cantering. Two consecutive failures to change would result in two five point penalties.*)
2. Blatant disobedience including kicking out, biting, bucking, and rearing.

### *3 points*

1. Not performing the specific gait (jog or lope) or not stopping when called for in the pattern, within 10 feet (3 meters) of the designated area.
2. Simple change of leads.
3. Out of lead at or before the marker prior to the designated change area or out of lead at or after the marker after the designated change area.
4. Additional lead changes anywhere in pattern (except when correcting an extra change or incorrect lead) failure to start the lope within 30 feet (9 meters) after crossing the log at the jog.
5. Break of gait at walk or jog for more than two strides.
6. Break of gait at the lope.

### *1 point*

1. Hitting or rolling log.
2. Out of lead more than one stride either side of the center point and between the markers.
3. Splitting the log (log between the two front or two hind feet) at the lope.
4. Break of gait at the walk or jog up to two strides.

### *1/2 point*

1. Tick or light touch of log.
2. Hind legs skipping or coming together during lead change.
3. Non-simultaneous lead change (front to hind or hind to front).

### **Disqualifications - 0 score**

1. Illegal equipment.
2. Willful abuse.
3. Off course.
4. Knocking over markers.
5. Completely missing log.
6. Major refusal - stop and back more than 2 strides or 4 steps with front legs.
7. Major disobedience or schooling.
8. Failure to start lope prior to end cone.
9. Four or more simple lead changes and/or failures to change leads.
10. Overturn of more than one-quarter turn.

### **TRAIL**

#### **Purpose**

The Trail class displays the ability of the rider to cause the animal to navigate obstacles such as those encountered on a trail ride. The animal should be well-mannered, quiet, and a pleasure to ride, with the ability to handle the obstacles with a calm, willing attitude. Trail is not a speed event, but rather a test of control and obedience.

#### **Tack and Attire**

1. Exhibitors in Trail may use Western, Hunter, or Saddle Type tack and attire but may not be mixed. Refer to requirements appropriate to riding style.
2. Prohibited: Mechanical hackamore, draw reins, tie downs, any type martingale, cavesson noseband in western bridle, protective leg wraps or boots, crop or whip in western tack.

#### **Class Procedures and Guidelines**

1. All obstacles used in the Trail class should be practical and realistic to simulate actual obstacles and hazards encountered on the trail.
2. All three gaits (walk, jog/trot (or equivalent breed gait) and lope/canter) are required to be demonstrated once each between obstacles in the pattern.
3. The exhibitor is asked to move to the next obstacle after three refusals on any one obstacle.
4. The pattern (to be determined by the show management) is to include a minimum of six obstacles, three of which are mandatory obstacles, and a maximum of eight obstacles. Others may be chosen from but are not limited to the list of optional obstacles.
5. The judge has the right and duty to alter the course or remove obstacles he/she deems unsafe.
6. Objects and obstacles should not be raised more than 12 inches off the ground.
7. Junior exhibitors are not asked to remount.
8. Horses must not be required to work on the rail.
9. Rein hand may be changed immediately prior to and immediately after working any obstacle that requires use of the hand to operate with no penalty (i.e., gate, mailbox, slicker, etc.).

## Example Obstacles

### Back Through

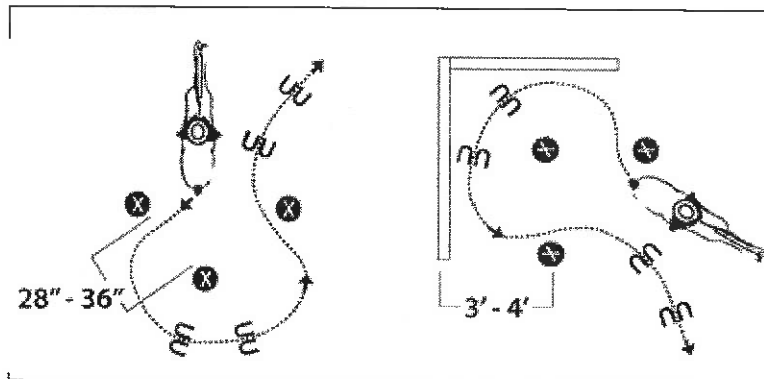

### Mandatory Obstacles

1. Gate (approximately 6 feet width). Changing hands on the gate or turning loose of gate is penalized.
2. Bridge (non-tilting).
3. Back (30 inch minimum between poles).

### Examples of Obstacles

#### Around Three Markers

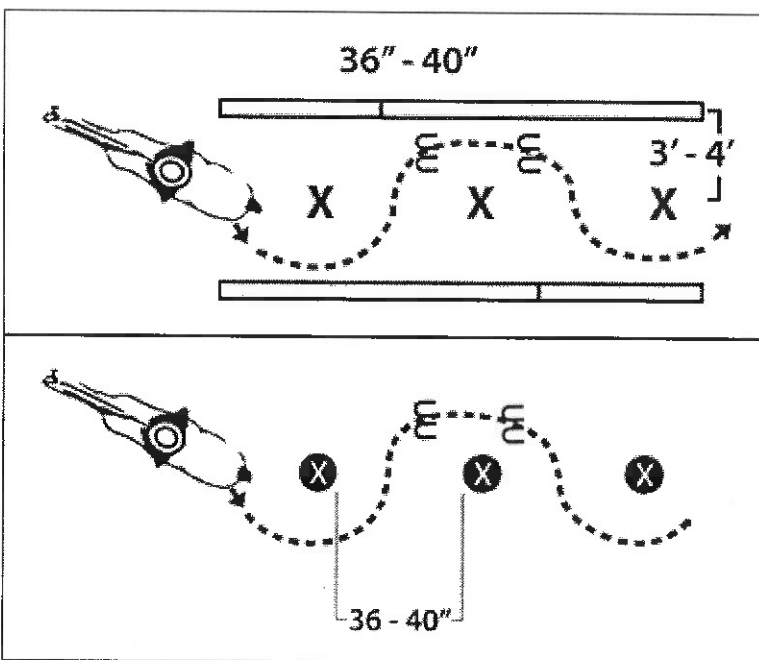

#### Jog /Trot Overs/Canter/ Lope Overs

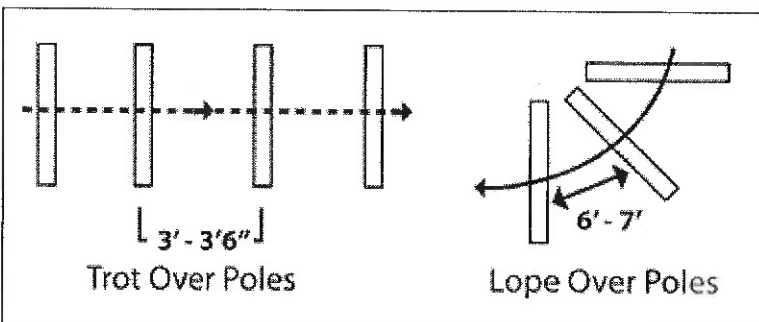

## Walk Overs

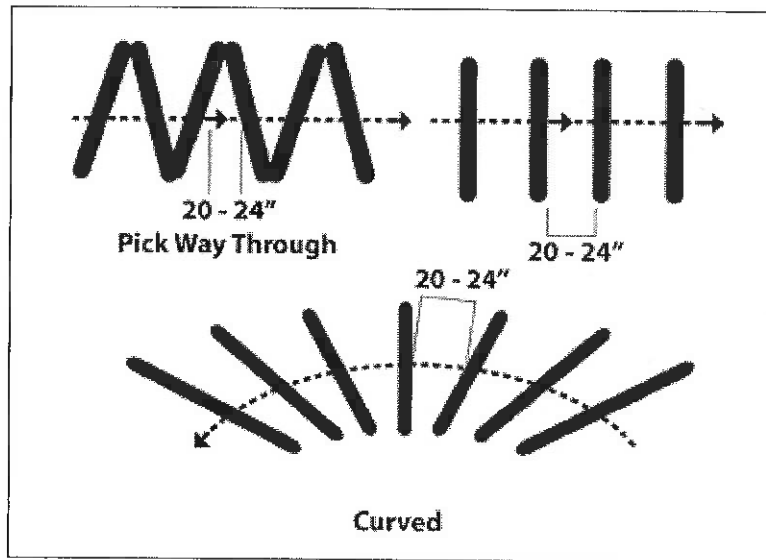

### Optional Obstacles

1. Water hazard.
2. Slicker.
3. Ground tie (if romal is used, hobble may be used or rein must be detached from one side of bit).
4. Ground poles (walk overs, 20-27 inches apart; trot overs, 36-40 inches; lope overs, 6-7 feet).
5. Mailbox.
6. Obstacle consisting of four logs or rails, each 5 feet to 6 feet long, laid in a square. Each contestant enters the square at the designated side, executes a 360 degree turn, pauses and departs by stepping over a log or rail immediately opposite the side of entry.
7. Pass by object normally found on a trail.
8. Serpentine obstacles at work or jog. Spacing to be minimum of 6 feet for jog.
6. Obstacle consisting of four logs or rails, each 5 feet to 6 feet long, laid in a square. Each contestant enters the square at the designated side, executes a 360 degree turn, pauses and departs by stepping over a log or rail immediately opposite the side of entry.
7. Pass by object normally found on a trail.
8. Serpentine obstacles at work or jog. Spacing to be minimum of 6 feet for jog.

## Variations of Sidepass

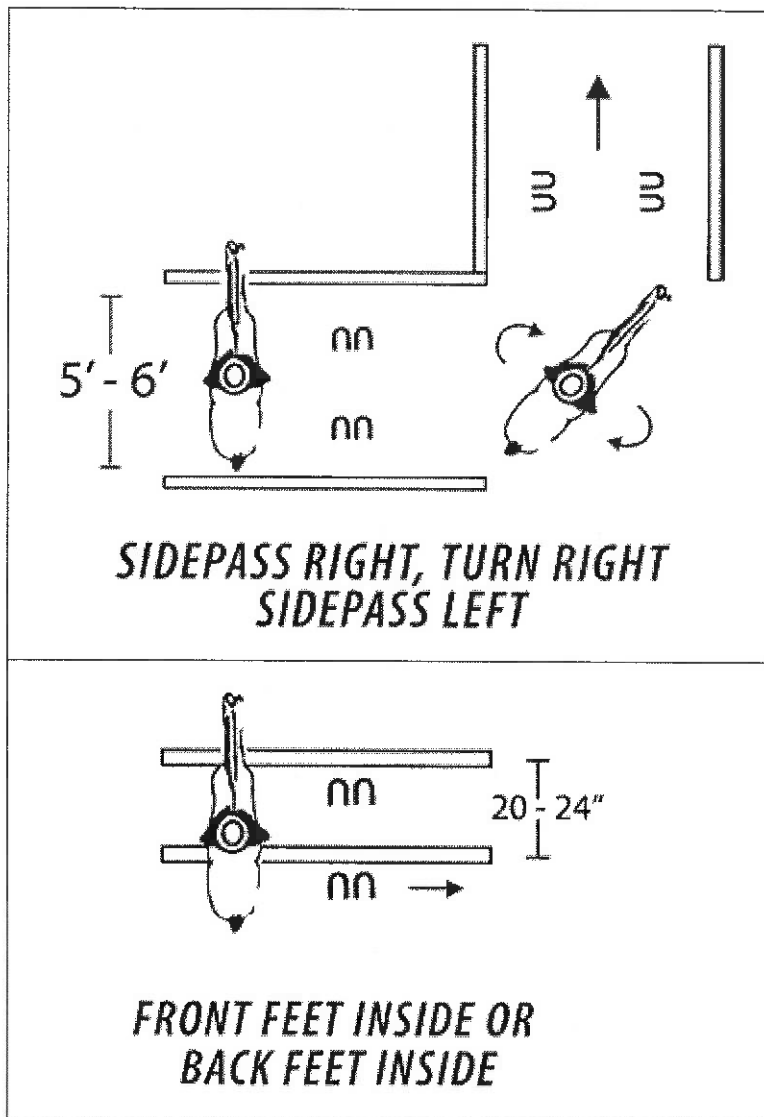

### Obstacles Not To Be Used

1. Loading in a trailer.
2. Obstacle involving the use of a rope or reata to be dragged or pulled by rider.
3. Tires in any form.
4. Live animals or hides.
5. Rocking bridge.
6. Jumps.
7. PVC pipe in ground obstacles.

### Scoring

Scoring is on the basis of 0-infinity, with 70 denoting an average performance. Each obstacle receives an obstacle score that should be added or subtracted from 70 and is subject to a penalty that should be subtracted. Each obstacle is scored on the following basis, ranging from plus 1 1/2 to minus 1 1/2: -1 1/2 extremely poor, -1 very poor, -1/2 poor, 0 correct, +1/2 good, +1 very good, +1 1/2 excellent. Obstacle scores are to be determined and assessed independently of penalty points. (See next page.)

## Variations of L Back Through

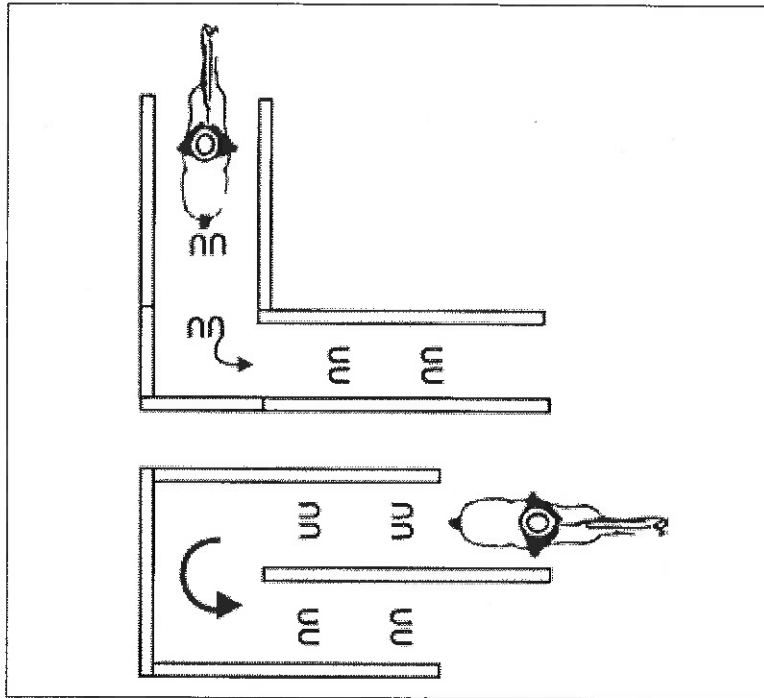

## Example of Jog/Trot Overs/Lope Overs/and Enter Walk Overs/Combination

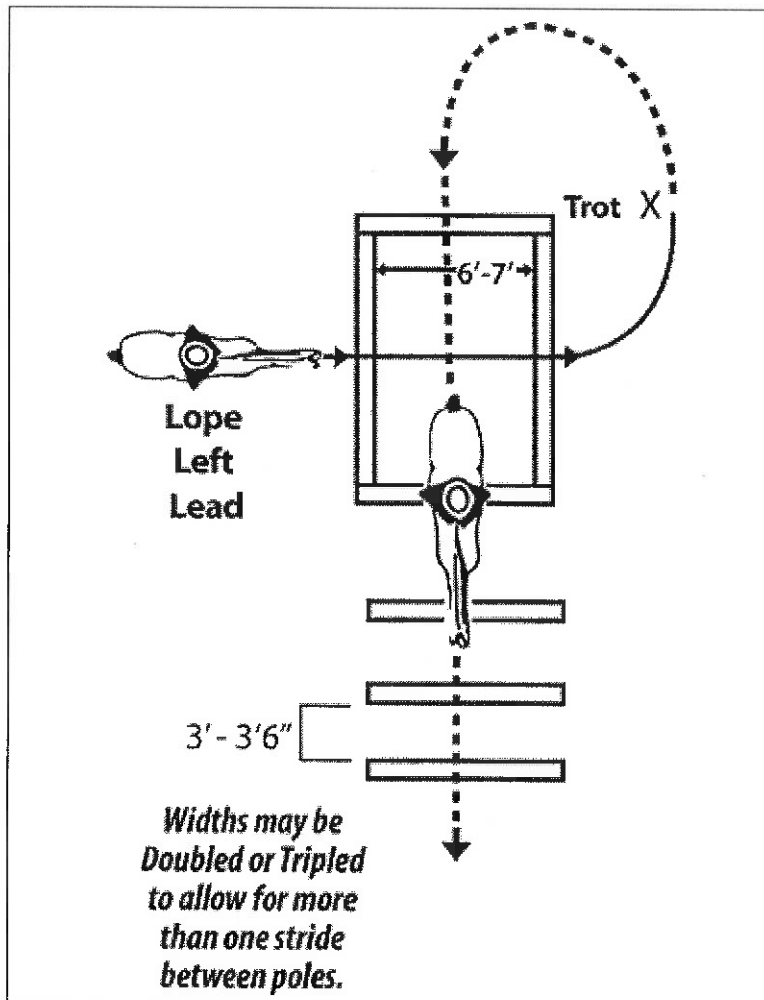

Penalties should be assessed per occurrence as follows. The following deductions result:

*5 Points*

1. Failure to follow the correct line of travel within or between obstacles.
2. Dropping slicker or object required to be carried on course.
3. First refusal, balk, or attempting to evade an obstacle by shying or backing more than 2 strides away.
4. Second refusal.
5. Letting go of gate or dropping rope gate.
6. Use of either hand to instill fear or praise.
7. Stepping outside the confines of, falling, or jumping off or out of an obstacle with more than one foot.
8. Blatant disobedience (kicking out, bucking, rearing, striking).
9. Failure to complete obstacle.
10. Faults, which occur on the line of travel between obstacles, scored according to severity:
  - a. Head carried too high.
  - b. Head carried too low (tip of ear below the withers).
  - c. Over-flexing or straining neck in head carriage so the nose is carried behind the vertical.
  - d. Excessive nosing out.
  - e. Opening mouth excessively.

*3 Points*

1. Break of gait at walk or jog for more than two strides.
2. Out of lead or break of gait at lope (except when correcting an incorrect).
3. Knocking down an elevated pole, cone, barrel, plant obstacle, or severely disturbing an obstacle.
4. Stepping outside the confines of, falling, or jumping off or out of an obstacle with one foot.

*1 Point*

1. Each hit of or stepping on a log, pole, cone or obstacle.
2. Incorrect gait at walk or jog for two strides or less.
3. Both front or hind feet in a single-stride slot or space.
4. Skipping over or failing to step into required space.
5. Split pole in lope-over.
6. Failure to meet the correct strides on trot over and lope over log obstacles.

*1/2 Point*

1. Each tick of log, pole, cone or obstacle.

*0 – Score*

1. Use of more than one finger between reins.
2. Use of two hands (except in snaffle bit or hackamore classes designated for two hands) or changing hands on reins; except for junior horses shown with hackamore or snaffle bit, only one hand may be used on the reins, except that it is permissible to change hands to work an obstacle.
3. Performing the obstacles incorrectly or other than in specified order.
4. No attempt to perform an obstacle.
5. Equipment failure that delays completion of pattern.

6. Excessively or repeatedly touching the horse on the neck to lower the head.
7. Fall to the ground by horse or rider.
8. Failure to enter, exit, or work obstacle from correct side or direction, including overturns of more than one-quarter turn.
9. Working an obstacle in any manner other than how it's described by the course.
10. Riding outside designated boundary marker of the arena or course area.
11. Third refusal.
12. Failure to demonstrate correct lead or gait, if designated.
13. Faults that occur on the line of travel between obstacles, which shall be scored according to severity:
  - a. Head carried too low (tip of ear below the withers consistently).
  - b. Over-flexing or straining neck in head carriage so the nose is carried behind the vertical consistently.

### **Disqualifications**

1. Unnecessary roughness as determined by the judge.
2. Failure to attempt obstacles in posted order.
3. Nine cumulative refusals on the course.

## **IN-HAND TRAIL**

### **Purpose**

The same as Trail class, but allowing the exhibitors to demonstrate handling, leading, and training skills with animals being led rather than ridden. The animal should be well-mannered, quiet, and a pleasure to handle, with the ability to negotiate the obstacles with a calm, willing attitude.

### **Scoring**

Same as Trail class.

1. Judges should consider the overall appearance of the horse, conditioning and grooming, and the equipment (dirty, ill-fitting or ragged equipment) in their overall scores.
2. Judged on correctness of the horse while being led: Drifting to the side, leading or stopping crooked, failure to maintain a pivot foot in a turn, leading or turning sluggishly should be considered and evaluated in the horse's maneuver scores and reflected in his overall score.
3. Handlers should be penalized for excessive verbal cues and excessive stiff or unnatural movements around horse or when leading. For safety reasons, those handlers continuously holding the chain on the lead, tightly coiling lead shank around hand, or dragging the lead shank should be penalized.

### **Class Procedures and Guidelines**

1. Exhibitor must use only the right hand on the lead where the chain begins, and lead on the horse's left side. A chain may be used under the chin or hanging from the halter, or if needed for safety control over the nose. Exhibitor must use only the left hand to carry the excess lead, looped loosely except when:



- a. Carrying an object from one part of the arena to another.
  - b. Dragging an object from one part of the arena to another.
  - c. Opening/closing a gate, left hand gate only. In these cases, the right hand can also carry the excess lead.
  - d. Sidepassing. In this case, the lead at the chain and the excess lead can be held in the hand at the horse's head.
2. Exhibitors should be poised, confident, courteous, and sportsmanlike at all times. The exhibitor should continue showing the horse until the class has been placed or excused.
  3. Any stops should be straight, smooth, and responsive with the horse's body remaining straight. Backing and turning should be performed from the left side of the horse. The exhibitor should face the horse when backing. Exception: When negotiating a gate, the exhibitor is not required to face the horse. The horse should back up readily with the head, neck, and body aligned in a straight or curved line as instructed.
  4. When executing a turn to the right, the exhibitor should face the horse and move the horse away from them. On turns of less than 90 degrees, it is acceptable to lead the horse toward them. On turns of 90 degrees or greater, the horse should pivot on the right or left hind leg while stepping across with the front legs.
  5. Exhibitor is not allowed to touch the horse, except when sidepassing.

## **REINING**

### **Purpose**

To rein a horse is not only to guide him but also to control his every movement. The best reined horse should be willingly guided or controlled with little or no apparent resistance and dictated to completely. Any movement on his own must be considered a lack of control. All deviations from the exact written pattern must be considered a lack of/or temporary loss of control and therefore a fault that must be marked down according to severity of deviation. Credit should be given for smoothness, finesse, attitude, quickness, and authority of performing various maneuvers, while using controlled speed that raises the difficulty level and makes him more exciting and pleasing to watch to an audience.

### **Tack and Attire**

1. Refer to Western tack and attire.
2. Optional: Skid boots, splint boots, protective leg wraps.
3. Prohibited: Mechanical hackamore, draw reins, tie down, any type martingale, cavesson noseband, crop, bat, and whip.

### **Class Procedures and Guidelines**

1. Each exhibitor performs the required pattern individually and separately.
2. One of the patterns listed below is selected by the judge and used by all contestants in the class.
3. Each animal is judged on the neatness, dispatch, ease, calmness, and speed with which it performs the pattern.

4. The judge shall indicate with markers on arena fence or wall the length of the pattern. Markers are placed on the wall or fence of the arena at the center of the arena and at least 50 feet from each end wall. Markers within the area of the pattern are to be used. Cone placement should be adjusted as needed to fit the arena.
5. Excess rein may be straightened at any place a horse is allowed to be completely stopped during a pattern. When using a romal, no fingers between the reins are allowed. The free hand may be used to hold the romal provided it is held at least 16 inches from the reining hand and in a relaxed position. Use of the free hand while holding the romal to alter the tension or length of the reins from the bridle to the reining hand is considered to be the use of two hands, and a score of 0 is applied.

### **Scoring**

0 to infinity, with 70 denoting an average performance. The individual maneuvers are scored in 1/2 point increments from a low of -1 1/2 (extremely poor) to a high of +1 1/2 (excellent) with a score of 0 denoting a maneuver that is correct with no degree of difficulty. Scores should be announced after each horse works.

Maneuvers scores should be awarded for each maneuver using the following scale:

- 1 1/2 Extremely poor
- 1 Very poor
- 1/2 Poor
- 0 Correct
- +1/2 Good
- +1 Very Good
- +1 1/2 Excellent

1. The following results in a penalty of 5 points:
  - a. Spurring in front of the cinch.
  - b. Use of free hand to instill fear.
  - c. Holding saddle with free hand.
  - d. Blatant disobedience including kicking, biting, bucking, earing, and striking.
2. The following results in a 2-point penalty:
  - a. Break of gait.
  - b. Freezing up in spins or rollbacks.
  - c. On walk in patterns, failure to walk or stop before executing a canter departure.
  - d. On run in patterns, failure to be in canter prior to reaching the first marker.
  - e. If a horse does not completely pass the specified marker before initiating a stop position.
3. Each time a horse is out of lead, a judge is required to penalize by 1 point. The penalty for being out of lead is cumulative, and the judge adds 1 penalty point for each one-quarter of the circumference of a circle or any part thereof that a horse is out of lead. A judge is required to penalize a horse 1/2 point for a delayed change of lead by one stride.

4. Deduct 1/2 point for starting circle at a jog or exiting rollbacks at a jog up to two strides. Jogging beyond two strides but less than half circle or one-half length of the arena, deduct 2 points.
5. Deduct 1/2 point for over or under spinning up to one-eighth of a turn; deduct 1 point for over or under spinning up to one-quarter of a turn.
6. When a change of lead is specified immediately prior to a run to the end of the pen, failure to change lead is penalized as follows: Failure to change leads by one stride, a 1/2 point penalty. Failure to change leads beyond one stride but where lead change is completed prior to the next maneuver, 1 point penalty. If the lead is not changed prior to the next maneuver, a 2 point penalty.
7. There is a 1/2 penalty for failure to remain a minimum of 20 feet from wall or fence when approaching a stop or rollback.

### **Disqualifications**

1. Use of any illegal equipment.
2. Use of reins or romal as a whip.
3. Abuse of the animal in the show arena and/or evidence that an act of abuse has occurred.
4. Use of more than one finger between reins.
5. Use of two hands on the reins (except snaffle or bosal) or changing hands.
6. Failure to complete the pattern as written.
7. Performing the maneuvers other than in specified order.
8. Including maneuvers not specified, including but not limited to:
  - a. Backing more than two strides.
  - b. Turning more than 90 degrees when not called for.
9. Equipment failure that delays completion of the pattern.
10. Balking or refusal of command where pattern is delayed.
11. Running away or failing to guide where it becomes impossible to discern whether the entry is on pattern.
12. Jogging in excess of one-half circle or one-half the length of arena.
13. Overspins of more than one-quarter turn.

## Patterns

### Pattern 1: Novice Reining Pattern

This pattern is NOT used at the Indiana State Fair.

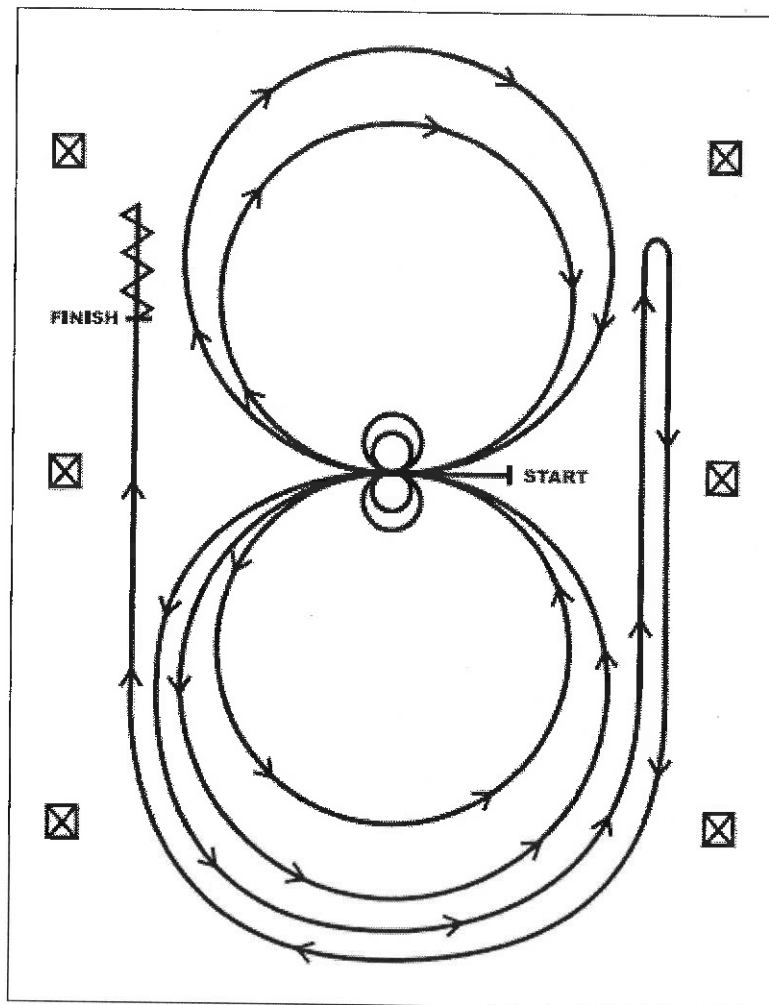

### Mandatory Marker Along Fence or Wall

The judge shall indicate with markers on arena fence or wall the length of the pattern. Markers within the area of the pattern are not used.

### Ride pattern as follows:

1. Horses may walk or trot to the center of the arena. Horses must walk or stop prior to starting the pattern. Beginning at the center of the arena facing the left wall or fence.
2. Beginning on the left lead, complete two circles to the left. Stop at the center of the arena. Hesitate.
3. Complete two spins to the left. Hesitate.
4. Beginning on the right lead complete two circles to the right. Stop at the center of the arena. Hesitate.
5. Complete two spins to the right. Hesitate.
6. Beginning on the left lead, go around the end of the arena, run down the right side of the arena past center marker, stop and roll back right.
7. Continue around the end of the arena to run down the left side of the arena past the center marker. Stop. Back up.
8. The bridle may be dropped at the judge's discretion.

## Reining Pattern 2 (NRHA Pattern 10)

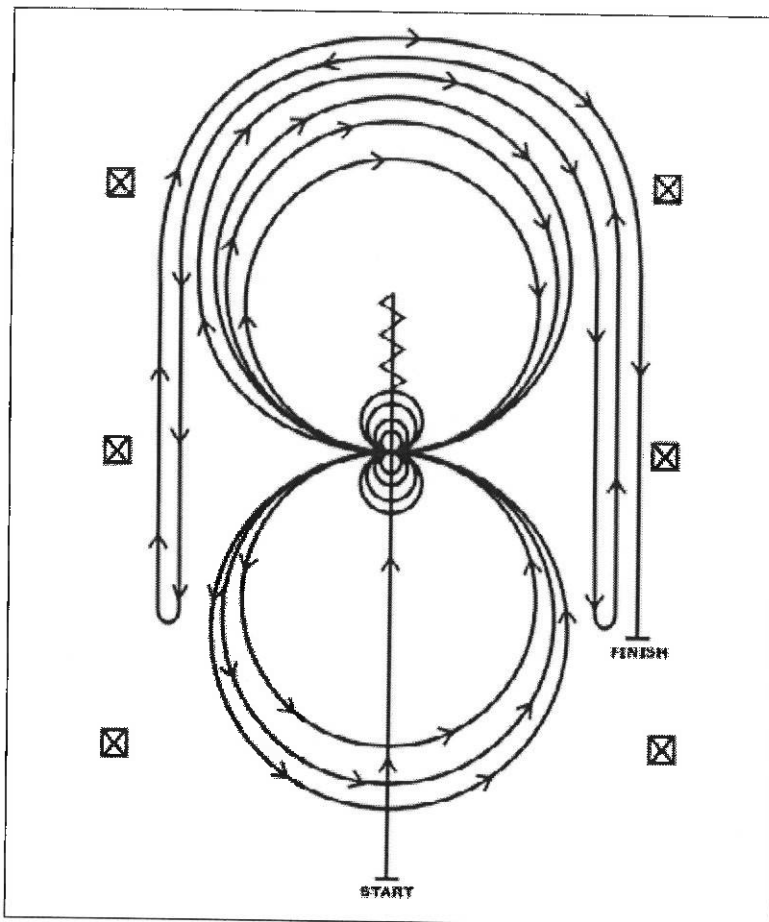

### Mandatory Marker Along Fence or Wall

1. Run past the center marker and do a sliding stop. Back up to the center of the arena or at least 10 feet (3 meters). Hesitate.
2. Complete four spins to the right. Hesitate.
3. Complete four and one-quarter spins to the left so that the horse is facing the left wall or fence. Hesitate.
4. Beginning on the right lead, complete three circles to the right: the first two circles large and fast; the third circle small and slow. Change leads at the center of the arena.
5. Complete three circles to the left: the first circle small and slow; the next two circles large and fast. Change leads at the center of the arena.
6. Begin a large fast circle to the right, but do not close this circle. Run down the right side of the arena past the center marker and do a left rollback at least 20 feet (6 meters) from the wall or fence – no hesitation.
7. Continue back around the previous circle but do not close this circle. Run down the left side of the arena past the center and do a right rollback at least 20 feet (6 meters) from the wall or fence – no hesitation.
8. Continue back around previous circle, but do not close this circle. Run down the right side of the arena past the center marker and do a sliding stop at least 20 feet (6 meters) from the wall or fence. Hesitate to demonstrate completion of the pattern.
9. The bridle may be dropped at the judge's discretion.

### Reining Pattern 3 (NRHA Pattern 7)

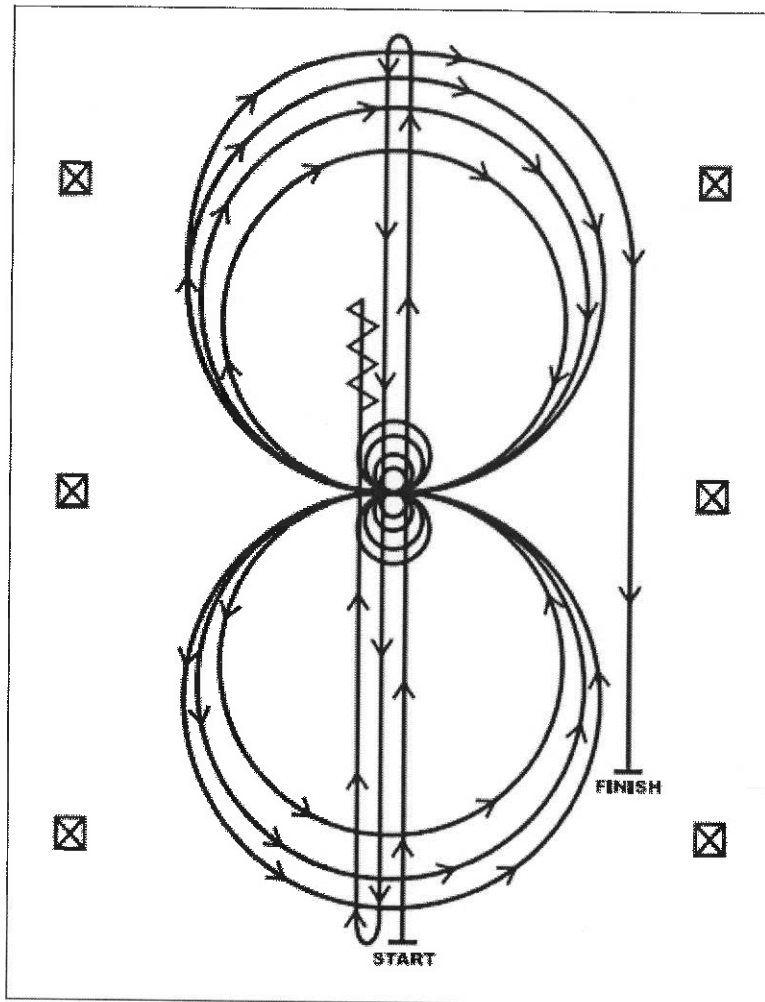

#### Mandatory Marker Along Fence or Wall

1. Run at speed to the far end of the arena past the end marker and do a left rollback – no hesitation.
2. Run to the opposite end of the arena past the end marker and do a right rollback – no hesitation.
3. Run past the center marker and do a sliding stop. Back up to the center of the arena or at least 10 feet (3 meters). Hesitate.
4. Complete four spins to the right. Hesitate.
5. Complete four and one-quarter spins to the left so that horse is facing left wall or fence. Hesitate.
6. Beginning on the right lead, complete three circles to the right: the first two circles large fast; the third circle small and slow. Change leads at the center of the arena.
7. Complete three circles to the left: the first two circles large fast; the third circle small and slow. Change leads at the center of the arena.
8. Begin a large fast circle to the right but do not close this circle. Run straight down the right side of the arena past the center marker and do a sliding stop at least 20 feet (6 meters) from the wall or fence. Hesitate to demonstrate completion of the pattern.
9. The bridle may be dropped at the judge's discretion.

## **BARREL RACE**

### **Purpose**

The Barrel Race is a timed event that tests the ability of the rider to safely maneuver their mount at speed around a prescribed course.

### **Tack and Attire**

1. Refer to Western tack and attire or English tack and attire. Stirrups may not be attached to each other, or the saddle, by any means except the stirrup leathers.
2. Optional Tack: Mechanical hackamore, closed reins, tie downs, martingales, cavesson nosebands, bats, crops, twisted wire snaffle bit, protective leg wraps or boots.
3. Optional Attire: Safety equipment such as protective vests or shin guards. One light rubber band, not to exceed 1/16 inch thick and 1/4 inch wide, may be wrapped only one time around each boot and stirrup.
4. Prohibited Equipment: Chain bits or any sharp bit, metal or cable nosebands.

### **Class Procedures and Guidelines**

1. The course should be measured exactly. A minimum of 4 yards is required between the barrels and fence to prevent accidents. If the course is too large for the available space, the pattern should be reduced 5 yards at a time until it fits the arena. Plastic barrels are required. No steel barrels with or without plastic guards may be used.
2. The barrel race is strictly a timed event. Electric timers or at least two stopwatches (operated by volunteers or show management) must be used. Penalties plus the time indicated by the timers or the average of the two stopwatches is the official time.
3. In a tie, the animal declared the winner in the run off must run the pattern in not more than 2 seconds over its original time, or the run off must be held again.
4. Contestant must enter the arena in a controlled manner, and start and stop the animal inside the ring. The gate must be closed behind the contestant and not opened until the contestant has finished the course. No animal is allowed into the ring until the previous contestant is excused.
5. Knocking over a barrel shall carry a 5 second penalty. (Three barrels knocked over shall be a disqualification.) Touching barrel with a hand is permissible. The contestant may start either to the right (making one right turn and two lefts turns) or to the left of the first barrel (making one left turn and two right turns.)
6. In case of timer failure, the participant is entitled to a rerun. If the initial run was a clean round and rerun was a penalty round, the participant is allowed one more rerun. The last run must be the official time.
7. Knocking down barrel - 5 second penalty for each barrel.

## Disqualifications

1. Knocking over three barrels.
2. Failing to follow course.
3. Spurring or striking horse forward of cinch.

## The Barrel Race

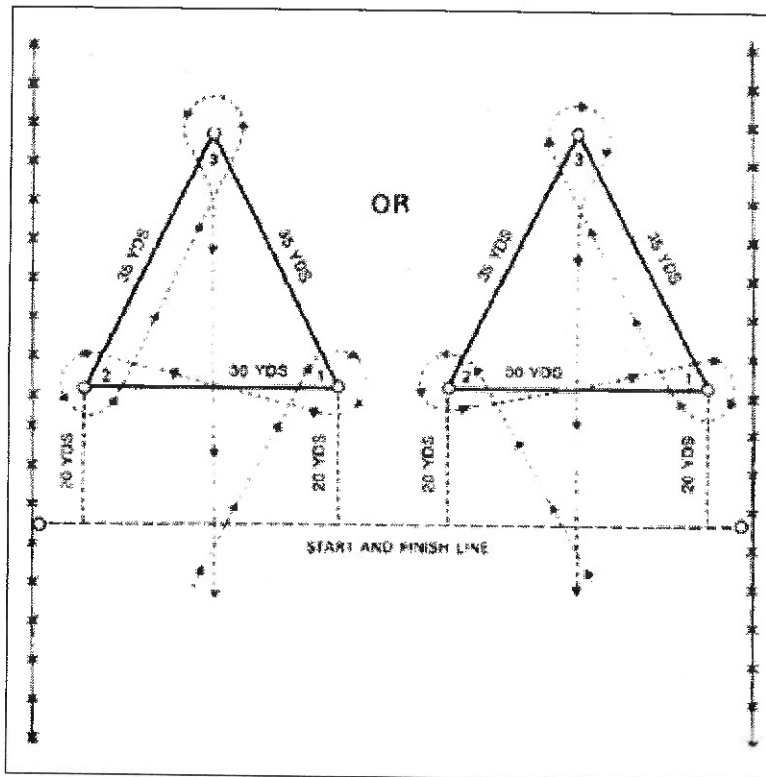

## FLAG RACE

### Purpose

The Flag Race is a timed event that tests the ability of the rider to safely maneuver their mount at speed around a prescribed course as well as the coordination of the rider on a set course.

### Tack and Attire

1. Refer to Western tack and attire or English tack and attire.
2. Optional Tack: Mechanical hackamore, closed reins, tie downs, martingales, cavesson nosebands, bats, crops, twisted wire snaffle bit, protective leg wraps or boots.
3. Optional Attire: Safety equipment such as a protective vest or shin guards. One light rubber band, not to exceed 1/16 inch thick and 1/4 inch wide, may be wrapped only one time around each boot and stirrup.
4. Prohibited Equipment: Chain bits or any sharp bit, metal or cable nosebands.

### Class Procedures

1. The course shall consist of three barrels set in a triangle pattern with a rubber or plastic container without handles (approximately 12 inches in diameter and 14 inches high) set on the two front barrels. Containers shall be filled with sand, soybeans, or like suitable porous material within 3 inches of top of container.



2. The first and third barrels are set in proximity to the timing line proportionate to the pattern and the arena size. Local management has the authority to determine the barrel pattern that best fits their arena subject to the restrictions addressed elsewhere in this description. The first and third barrels are 34 yards apart. The first and second and the third and second barrels are 37 yards apart. Each of the three barrels must be a minimum of 4 yards from the fence. If the course is too large for the available space, the pattern should be reduced 5 yards at a time until it fits the arena. The course may be run either to the right or left. The rider may also choose to run to the inside or outside of both the first and third barrel, but must pass outside the second barrel. The barrels are not moved.
3. The flag used should be made of wood, from 13 inches to 16 inches long and 3/4 to 1 inch in diameter with a maximum 6 inch-by-6 inch cloth flag attached to the untapered end. The other end shall be tapered. Show management must place tapered end of flag consistently 3 inches deep in center of bucket. The contestant must enter the ring in a controlled manner, and start and stop the animal inside the ring. The gate must be closed behind the contestant and not opened until the contestant has finished the course. No animal is allowed into the ring until the previous contestant is excused.
4. The contestant is allowed a running start. Time begins when the animal's nose passes over the starting line and ends when its nose passes over the finish line.
5. Rider must pick flag up at first barrel, proceed around second barrel, stick flag in container on third barrel, and proceed across the finish line.
6. The Flag Race is strictly a timed event. Electric timers or at least two stopwatches (operated by volunteers or show management) must be used. Penalties plus the time indicated by the timer or the average of the two stopwatches is the official time.
7. In a tie, the animal declared the winner in the run off must rerun the pattern within 2 seconds of its original time, or the run off must be held again.
8. In case of timer failure, the participant is entitled to a rerun. If the initial run was a clean round and the rerun was a penalty round, the participant is allowed one more rerun. The last run must be the official time.
9. Failure to stick flag in top of container or dropping flag after rounding the second barrel - 10 second penalty.

### **Disqualifications**

1. Spurring or striking animal forward of cinch.
2. Knocking over any barrel or container, failing to stay on course, (i.e., circling or backing).
3. Failing to pick up flag from first container or dropping flag before second barrel.
4. Striking animal with flag.
5. Failure to pass both inside or outside of both first and third barrels.

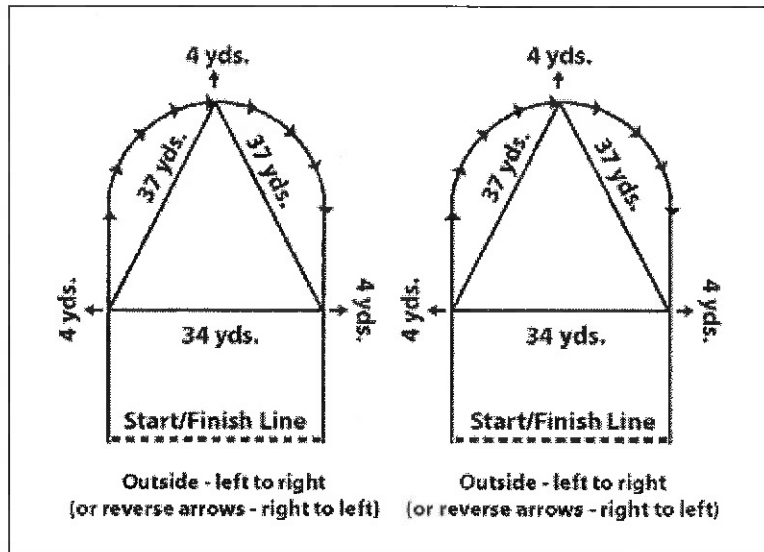

## KEYHOLE RACE

### Purpose

The Keyhole Race is a timed event that tests the ability of the rider to safely maneuver their mount at speed, stop and turn on a prescribed course.

### Tack and Attire

1. Refer to Western tack and attire or English tack and attire.
2. Optional Tack: Mechanical hackamore, closed reins, tie downs, martingales, cavesson nosebands, bats, crops, twisted wire snaffle bit, protective leg wraps or boots.
3. Optional Attire: Safety equipment such as a protective vest or shin guards. One light rubber band, not to exceed 1/16 inch thick and 1/4 inch wide, may be wrapped only one time around each boot and stirrup.
4. Prohibited Equipment: Chain bits or any sharp bit, metal or cable nose bands.

### Class Procedures and Guidelines

1. The Keyhole must be marked on the ground with flour, lime, or other suitable substance. The starting line shall be 50 feet to 100 feet (according to arena size) from the entrance to the Keyhole. The entrance shall be 4 feet wide and 10 feet long, connected to a circle 20 feet in diameter. All portions of the Keyhole must be a minimum of 4 yards from the fence.
2. The contestant must enter the ring in a controlled manner, and start and stop the animal inside the ring. The gate must be closed behind the contestant and not opened until the contestant has finished the course. No animal is allowed into the ring until the previous contestant is excused.
3. The contestant is allowed a running start. Time starts as the contestant crosses the starting line. The rider shall proceed through the entrance, turn right or left in the circle, return through the entrance and cross the finish line.

4. The Keyhole Race is strictly a timed event. Electric timers or at least two stopwatches (operated by volunteers or show management) must be used. The time indicated by the timer or the average of the two stopwatches is the official time.
5. In a tie, the animal declared the winner in the run off must rerun the pattern within 2 seconds of its original time or the run off must be held again.
6. In case of timer failure, the participant is entitled to a rerun. If the initial run was a clean round and the rerun was a penalty round, the participant is allowed one more rerun. The last run must be the official time.
7. Stepping on or outside of the chalk line is a disqualification.

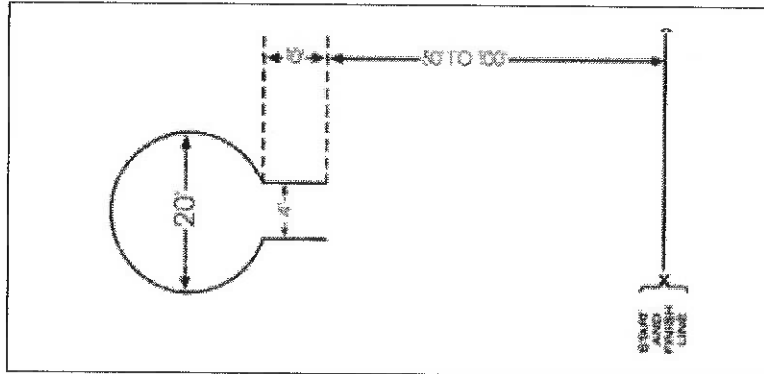

### Disqualifications

1. Stepping on or outside of the chalk line.
2. Spurring or striking animal forward of cinch.
3. Failing to stay on course, all four feet outside of the chalk line.

### POLE BENDING

#### Purpose

Pole Bending is a timed event that tests the ability of the rider to safely maneuver their mount at speed around a prescribed course.

#### Tack and Attire

1. Refer to Western tack and attire or English tack and attire.
2. Optional Tack: Mechanical hackamore, closed reins, tie downs, martingales, cavesson nosebands, bats, crops, twisted wire snaffle bit, protective leg wraps or boots.
3. Optional Attire: Safety equipment such as protective vests or shin guards, one light rubber band, not to exceed 1/16 inch thick and 1/4 inch wide, may be wrapped only one time around each boot and stirrup.
4. Prohibited Equipment: Chain bits or any sharp bit, metal or cable nose bands.

#### Class Procedures and Guidelines

1. The Pole Bending pattern is to be run around six poles. Each pole is to be 21 feet apart, and the first pole is to be 21 feet from the starting line. All poles must be a minimum of 4 yards from the fence.
2. Each pole should be set on top of the ground, be at least 6 feet in height and have a base no more than 14 inches in diameter.

3. An animal may start either to the right or to the left of the first pole and then run the remainder of the pattern accordingly.
4. Touching pole with the hand is permissible.
5. Knocking over a pole shall carry a 5 second penalty. (Three or more poles knocked over shall mean disqualification.)
6. Pole Bending is strictly a timed event. Electric timers or at least two stopwatches (operated by volunteers or show management) must be used. Penalties plus the time indicated by the timer or the average of the two stopwatches is the official time.
7. In a tie, the animal declared the winner in the run off must rerun the pattern within 2 seconds of its original time, or the run off must be held again.
8. The contestant must enter the ring in a controlled manner, and start and stop the animal inside the ring. The gate must be closed behind the contestant and not opened until the contestant has finished the course. No animal is allowed into the ring until the previous contestant is excused.
9. The contestant is allowed a running start. Time begins when the animal's nose passes over the starting line and ends when its nose passes over the finish line.
10. In case of time failure, the participant is entitled to a rerun. If the initial run was a clean round and the rerun was a penalty round, the participant is allowed one more rerun. The last run must be the official time.
11. Knocking down pole – 5 second penalty for each pole.

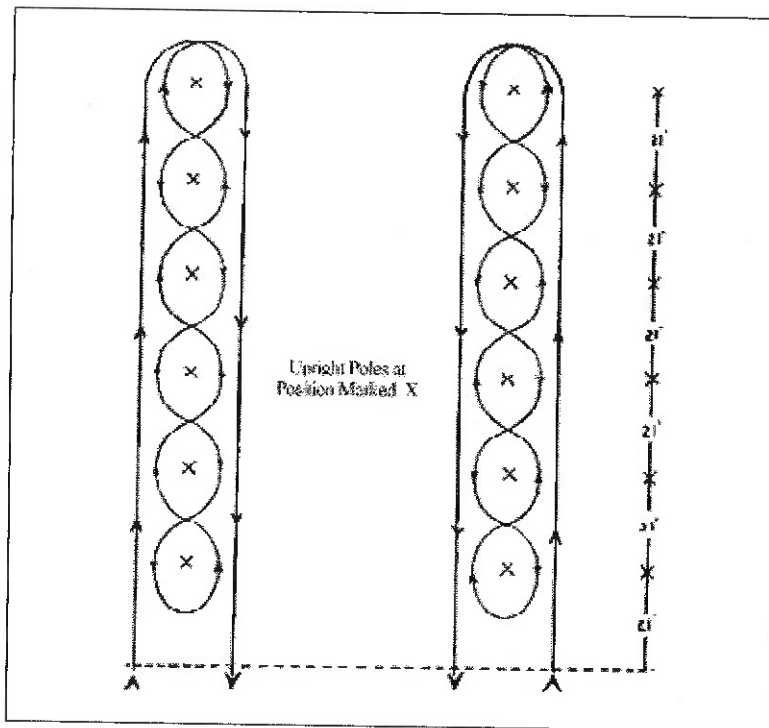

### Disqualifications

1. Knocking over three or more poles.
2. Failure to follow the course.
3. Spurring or striking the animal forward of the cinch.

## SPEED AND ACTION

### Purpose

Speed and Action is a timed event that tests the ability of the rider to safely maneuver their mount at speed and stop and turn on a prescribed course.

### Tack and Attire

1. Refer to Western tack and attire or English tack and attire.
2. Optional Tack: Mechanical hackamore, closed reins, tie downs, martingales, cavesson nosebands, bats, crops, twisted wire snaffle bit, protective leg wraps or boots.
3. Optional Attire: Safety equipment such as a protective vest, shin guards, one light rubber band, not to exceed 1/16 inch thick and 1/4 inch wide, may be wrapped only one time around each boot and stirrup.
4. Prohibited Equipment: Chain bits or any sharp bit, metal or cable nose bands.

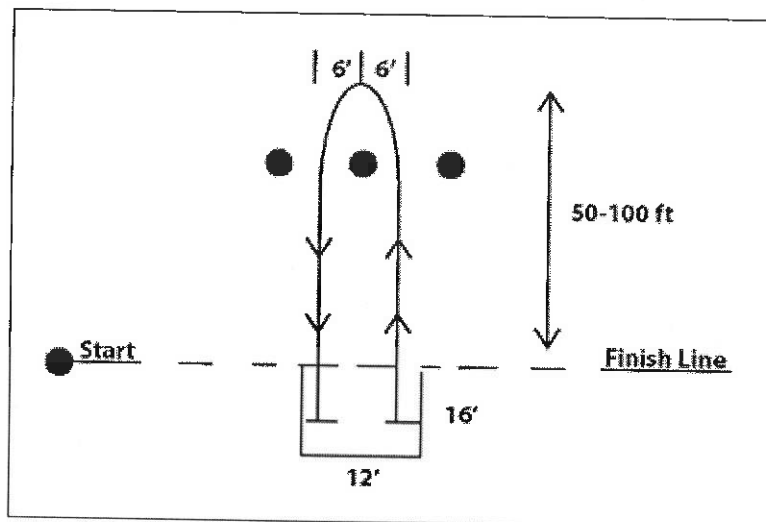

### Class Procedures and Guidelines

1. The speed and action pattern, runs through the box, across the start line 50 to 100 feet, runs around a middle cone, and runs back across the finish line and stops in the box until dismissed by the judge.
2. The three-sided box must be marked with lime or flour and be 12 feet by 16 feet and marked by cones at each corner. The side of the box closest to the cones must be on the start/finish line.
3. The line of three cones should be 50-100 feet from the start/finish line with the middle cone even with the middle of the box, and the cones should be 6 feet apart.
4. The contestant must enter the ring in a controlled manner, and start and stop the animal inside the ring. The gate must be closed behind the contestant and not opened until the contestant has finished the course. No animal is allowed into the ring until the previous contestant is excused.
5. Contestants can run down and turn left or right around the middle cone, but must not go around the outside cones, jump over a cone, or cross their own path while turning.

6. The contestant is allowed a running start. Time starts as the contestant crosses the starting line. Time ends when the entry again crosses the finish line, but the animal must stop with no forward motion and under control within the box until released by the judge. There is no length of time required; the judge must release the entry verbally as soon as the entry has stopped to the judge's satisfaction.
7. Time should be announced after each qualified run.
8. In case of timer failure, the participant is entitled to a rerun. If the initial run was a clean round, and the rerun incurs a penalty, the participant is allowed one more run. The final run must be the official time.
9. Knocking over a cone carries a 5-second penalty.

### **Disqualifications**

1. Stepping on or over the line of the box before being released by judge.
2. Jumping over a cone or failure to follow pattern between cones.
3. Crossing path or doing a Texas rollback around the cones.
4. Turning more than 180 degrees when achieving a stop in the box.
5. Spurring or striking the animal forward of the cinch.
6. Failure to complete the pattern as written.

## **DRESSAGE**

### **Purpose**

Dressage (pronounced like *massage*) is a system of skilled horsemanship that draws its foundation from the basic communication and execution between the rider and their mount. Dressage provides a method in which the 4-H member teaches a horse to be obedient, willing, supple, and responsive.

### **Dressage Tack – Performance**

1. Exhibitors must use an English type saddle with stirrups. Saddle pads are optional, but should be white or a conservative color.
2. A plain snaffle bridle is required with either a regular cavesson, a dropped noseband, a flash noseband (a combination of a cavesson noseband and a dropped noseband attachment) or a figure eight noseband. Except for the buckles, the noseband must be made entirely of leather or leather-like material. A padded noseband is allowed.
3. The bit used must be a snaffle with a smooth or solid surface.
4. Kimberwick, twisted, wire and roller bits are prohibited. A bushing or coupling is permitted as the center link in a double jointed snaffle. The mouthpiece of a snaffle may be shaped in a slight curve, but ported snaffles are prohibited. The diameter of the bit must be a minimum of 3/8 inch diameter at rings or cheeks of the mouthpiece.
5. Optional: One whip no longer than 48 inches including lash, breastplate and/or crupper, braiding of mane and/or tail.
6. Prohibited: Martingales, bit guards, any kind of training device (such as bearing, side, running, balancing reins, nasal strips, tongue tied down, etc.), any kind of boots or bandages, Kimberwick, twisted, wire and roller bits.

## **Dressage Attire**

1. Riders must wear a short riding coat of conservative color, with tie, choker or stock tie, white or light-colored breeches or jodhpurs, boots or Jodhpur boots, and approved protective headgear. Riders through First Level may wear half-chaps, gaiters, or leggings in solid black or brown, without fringe, matching color of their boots, and made of smooth leather or leather-like material. In extreme heat and/or humidity competitors may be allowed to show without riding coats. However, competitors must wear a solid white or very pale-colored long-sleeved shirt, without neckwear.  
\*At the discretion of the judge.
2. ASTM and/or SEI standard F1163 or approved protective headgear is required in all dressage classes and while mounted.
3. Hair must be neat and contained, as in a braid or hairnet, and must not obscure exhibitor number.
4. Competitors are allowed to wear a hat cover and a transparent or conservative color raincoat in inclement weather.
5. Spurs must be made of metal. The shank must be either curved or straight pointing directly back from the center of the spur when on the rider's boot. If the shank is curved, the spurs must be worn only with the shank directed downwards. Swan neck spurs, metal spurs with round hard plastic knobs on the shanks, and "dummy" spurs with no shank are allowed.
6. Optional: Gloves of white or conservative color; spurs.
7. Prohibited: Dark colored breeches or jodhpurs.

## **Guidelines**

1. The conducting of Dressage classes at the local 4-H show is simple and no more complicated than Trail, Western Riding, or Hunter Over Fences. For assistance with equipment, clinics, judges, and other information about dressage, show management are encouraged to contact the Indiana Dressage Society ([www.indianadressage.org](http://www.indianadressage.org)).
2. Dressage classes require a relatively level area, letters, an area boundary fence, a judge and scribe with dressage experience, and a designated volunteer to help the 4-H members prepare for the dressage tests.
3. Dressage events should be held in a standard size arena, 20 meters by 60 meters (65.6 feet by 196.8 feet), with a low border (plastic chains, hunter fence rails laid on the ground, or any other visible border lower than 1 foot in height). A smaller, 20 meter by 40 meter (65.6 feet by 131.2 feet), arena can be used. 1 meter = 39.37 inches/1.094 yards. A section easy to open should be at the end opposite the judge's stand (A) to let in the riders. A small dressage arena can be set inside most county horse show arenas or out in a level field. See Figure 1 for setting up a standard 20 meter by 60 meter dressage arena.

Figure 1.

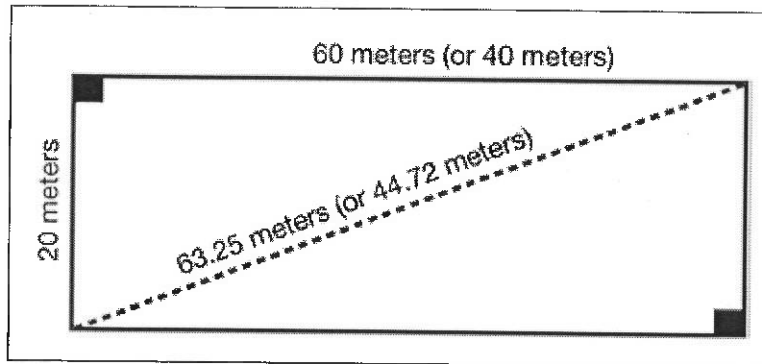

- Arena dressage letters should be placed on the inside of a conventional horse show arena fence or preferably just outside of the dressage arena border. Your club can easily make a set of letters from plastic, metal, or wood. The letters should be placed so they are visible to the judges and competitors as shown in the following diagram taken with permission from the USDF Calendar of Competitions:

### Measuring a Dressage Ring

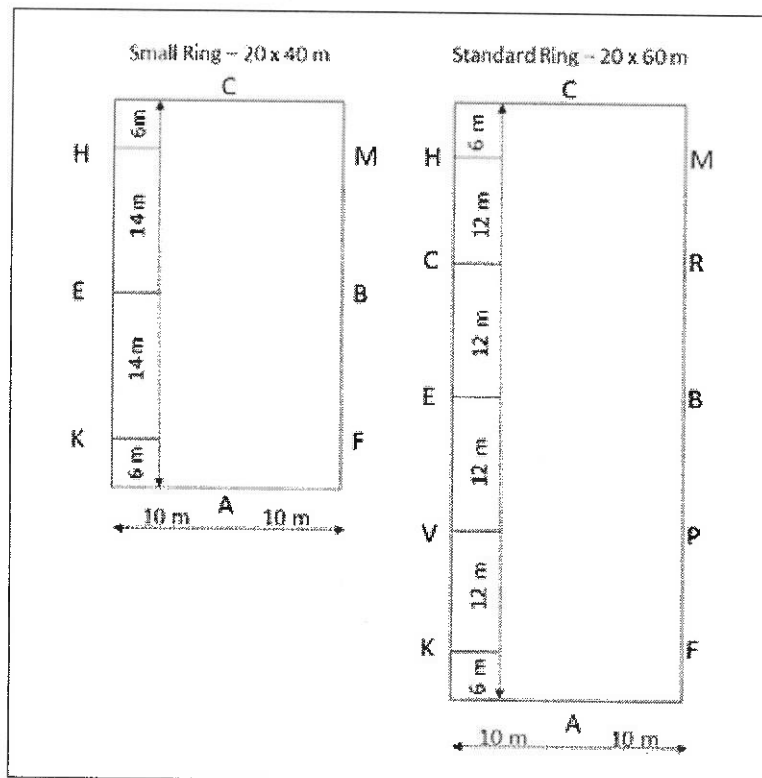

### Class Procedures

- The county 4-H Horse & Pony committee should determine the classes (tests) to be offered. All riders in one class should ride the same test in the same level. Once entries are made, assign a time for each rider to ride, allowing five to eight minutes for each rider. The average time to ride each test is indicated at the top of each test description and on the score sheet. Riders may enter any of the tests in any two consecutive levels (introductory, training, and first).



2. The judge should use a whistle or bell to signal for the next rider.
3. Riders have 45 seconds after the signal to enter the dressage arena and begin the test. All tests begin with a straight line to the middle of the arena (X), halt, and salute. At the salute the rider must take the reins in one hand, let one arm drop loosely along his/her body and then incline his/her head in a slight bow. Rider may choose to use a reader to "call the test," reading each movement once. Readers should stand outside the dressage arena at B or E. The use of a reader results in no discrimination. It is the responsibility of the exhibitor, not the management, to arrange for a person to "call" their test.
4. The judge and scribe (jury) should be seated at a table or elevated stand at (C), outside the end of the arena opposite the entrance gate (A).
5. At the completion of the test and the final salute to the judge, the rider should ride forward a few steps at a free walk on a long rein, then loop back and exit at (A).
6. Judges and scribes should complete the score sheets. A volunteer(s) usually tabulates the scores, ranks the riders, and makes the score sheets available to the riders. Judges are encouraged to make individual or collective comments to the 4-H members. Remarks and comments on the score sheets provide educational inputs for improvement.

### **Scoring**

1. Movements. Each movement is scored on the basis of control, effectiveness of rider's aids, and accuracy of the movement as follows:
  - 10 = Excellent
  - 9 = Very Good
  - 8 = Good
  - 7 = Fairly Good
  - 6 = Satisfactory
  - 5 = Sufficient
  - 4 = Insufficient
  - 3 = Fairly Bad
  - 2 = Bad
  - 1 = Very Bad
  - 0 = Not Executed
  - a. Depending on the test, some movements have coefficients that increase their emphasis.
2. Voice. The use of the voice in any way or clicking the tongue is a serious fault, causing a 2-point deduction from the marks that would have been otherwise awarded to the movement where the fault occurred.
3. Errors. When an exhibitor makes an "error of test" (takes a wrong turn, omits a movement, etc.) the judge should blow a whistle or bell, call the rider to them, and instruct the rider what the correct movement was; and the rider should pick up the test at the point where the error occurred. The rider should be penalized 2 points for the first error, 4 points for the second error, and be disqualified for the third error. The disqualified rider is allowed to continue their performance

to the end or until the judge chooses to end the performance and instruct the rider of their errors.

4. **Collective Marks.** General criteria including gaits (freedom and regularity), impulsion (desire to move freely forward in a clear and steady tempo), submission (obedience, confidence, and relaxed acceptance of the aids; horse should be ridden on a light but steady contact), and especially the rider (correctness of position, balance and harmony with horse; effectiveness and use of aids) are emphasized with coefficients of two or three as indicated.
5. In all competitions the winner is the competitor having the highest total points; the second placed competitor is the one with the next highest total points, and so on. In case of equality of points the competitor with the highest marks received under General Impressions shall be declared the winner. When the scores for General Impressions tie, the judge may be required to decide on the winner after review of both score sheets, or the horses may remain tied.

### **Disqualifications**

1. More than two course errors.
2. Prolonged resistance that prevents continuation of test.
3. Failure to enter the arena within 45 seconds of bell or whistle being sounded.
4. Leaving the arena before completion of the test (stepping all four feet outside the border). Official score sheets must be used, and competitors should receive their sheets at the end of the dressage competition. Score sheets for the current introductory level tests can be obtained from the United States Dressage Federation ([www.usdf.org](http://www.usdf.org)). Score sheets for the current Training through Fourth level tests can be printed from the United States Equestrian Federation website ([www.usef.org](http://www.usef.org)). Show management must follow the test guidelines outlined by the USEF (<http://www.usef.org/documents/disciplines/dressage/TestGuidelines.pdf>). The USDF and USEF change the dressage tests regularly. Please verify at the beginning of each competition year that you are using the most current tests.

## **WALK-TROT EQUITATION/HORSEMANSHIP**

### **Purpose**

Walk-Trot Equitation/Horsemanship provides an opportunity to participate for 4-H members whose inexperience or disability prevents them from riding their animal at the canter or lope. Exhibitor displays his or her ability as a rider, i.e., the seat, hand, leg position, and ability to control and show the mount, in a class that is appropriate to their skill level. Exhibitors in this class may not show in any class requiring the canter (lope) at the same show. Walk-Trot Equitation/Horsemanship is to be evaluated by the performance of the horse as a reflection of the ability of the rider.

### **Tack and Attire**

Appropriate to the selected riding style. Refer to appropriate section of this handbook.

### **Class Procedures and Guidelines**

1. The entire class shall be worked at a walk and trot (or equivalent breed gait) both ways of the ring. Extended gaits may be asked for. At the judge's discretion, the class may be asked to back.
2. The class is to enter the ring at the walk, and proceed at the ringmaster's instruction.
3. One "spotter" is allowed per rider. That spotter must not be between the horse and the judge, and may not touch, guide, or control the horse in any way. They may provide verbal coaching, but not to a degree that disrupts other riders in the ring. Spotters may be either 4-H members or adults, and must be neatly and safely attired (long pants, boots, no advertising insignia).
4. This class may be split into walk-trot with assistance (a spotter in the ring), and walk-trot without assistance (no spotter) divisions, at the discretion of the show management.
5. The class may be split into open walk trot, and a challenged rider's class at the discretion of show management.

### **Disqualifications**

1. Spotter touching, guiding, or controlling the horse, or otherwise interfering with the judge's ability to evaluate the class.
2. Equipment failure, or use of unsafe equipment or practices, causing an unsafe condition, as determined by the judge, equipment steward, show management, or Extension staff. Equipment used to attach a child to the tack or horse is considered unsafe, and is grounds for disqualification.
3. Showing in classes requiring the canter or lope at the same show.

## **LEADLINE EQUITATION/HORSEMANSHIP**

### **Purpose**

Leadline Equitation/Horsemanship provides an opportunity to participate for 4-H members whose inexperience or disability prevents them from controlling their animal independently. The exhibitor displays his or her ability as a rider, i.e., the seat, hand, leg position, and ability to steer and show the mount, in a class that is appropriate to their skill level. Exhibitors in this class may not show in any class requiring independent riding at a trot (jog) or canter (lope) at the same show. Leadline Equitation/Horsemanship is to be evaluated on the rider's position, and active involvement in guiding the animal.

### **Tack and Attire**

Appropriate to the selected riding style. Refer to appropriate section of this handbook.

### **Class Procedures and Guidelines**

1. The entire class shall be worked at a walk both ways of the ring. At the judge's discretion, the class may be asked to back, or to trot. Show management should communicate their expectations regarding gaits to the judge prior to the class entering the ring.
2. The class is to enter the ring at the walk, and proceed at the ringmaster's instruction.
3. Each rider is allowed up to three assistants (a leader and two side walkers). These assistants may be either 4-H members or adults, and must be neatly and safely attired (long pants, boots, no advertising insignia).
4. This class may be split into leadline with assistance (would include sidewalkers), and leadline without assistance (only a leader, no sidewalkers) divisions, at the discretion of the show management.
5. The class may be split into open walk trot, and a challenged rider's class at the discretion of show management

### **Disqualifications**

1. Equipment failure, or use of unsafe equipment or practices, causing an unsafe condition, as determined by the judge, equipment steward, show management or extension staff. Equipment used to attach a child to the tack or horse is considered unsafe and is grounds for disqualification.
2. Showing in classes requiring independent riding at the trot or canter at the same show.

## GLOSSARY

**Action:** The manner in which an animal travels and moves.

**Age (Animal):** The age of an animal shall be computed on the basis of a calendar year starting on January 1 of year foaled. Junior Horse shall be considered an animal 5 years of age and younger. Senior Horse shall be considered an animal 6 years of age and older.

**Age (Exhibitor):** Youth may become 4-H members when they enter the third grade and continue thru grade 12. These individuals may continue their 4-H membership for a maximum of 10 years. For summer shows, a child's grade in school is the grade they were in on January 1 of the current year. Each 4-H member advances one grade per year, regardless of academic status.

**Appointments:** The equipment and clothing used in showing.

**Approved Protective Headgear:** Refer to page 6.

**Bat:** A flat riding whip.

**Bight:** Excess reins that should hang on the shoulder of the rein hand side of the horse when using split reins.

**Bosal:** A braided rawhide or leather bosal may be used in lieu of a snaffle bit, no larger than 3/4 inch diameter at the cheek; must be a minimum of a one-finger space between the bosal and nose; absolutely no metal under the jaw or on the noseband in connection with the bosal. The bosal should be properly fitted relative to the horse's size and conformation. Refer to page 34.

**Breed Gait:** A four-beat gait, such as a rack, fox trot, running walk, paso largo, or slow gait. Used by these breeds in classes rather than the trot.

**Bridle, Full:** A bridle with separate curb and snaffle bits, separate cheekpieces and two sets of reins.

**Bridle Path:** Clipped section of mane behind the poll to allow better fit of bridle headstall.

**Canter:** A collected English, three-beat gait, smooth, balanced and moderately slow (not a fast gait), with rhythm in its action.

**Cantle:** Raised portion of saddle directly behind seat.

**Cavesson:** A noseband on a bridle.

**Colt:** A male horse/pony under 3 years of age.

**Conformation:** The build of an animal; the structure, form, balance and symmetrical arrangement of parts.

**Crop:** Short, handheld riding whip.

**Curb Strap, Acceptable:** See page 33.

**Dam:** The female parent of an animal.

**Diagonal:** Refers to the rising (posting) of the rider at the trot. Correct diagonal is "rise and fall with the leg on the wall."

**Equitation:** The art of riding horseback; horsemanship equivalent.

**Falling of Animal:** An animal is considered to have fallen when shoulder and hind quarters on the same side have touched the ground.

**Falling of Rider:** A rider is considered to have fallen when he/she is separate from his/her animal, which has not fallen, in such a way as to necessitate remounting. A driver is considered to have fallen when he/she touches the ground.

**Farrier:** A horseshoer; blacksmith.

**Filly:** A female horse/pony under 3 years of age.

**Foal:** A young horse/pony of either sex during the calendar year of its birth.

**Gaits:** The forward motion of the horse/pony at various speeds  
Example: walk, trot, canter.

**Gelding:** A castrated male horse/pony/donkey/mule.

**Groom:** An assistant in the cart in case of emergencies in driving and in restraining an animal for safety purposes during the class.

**Hackamore (Mechanical):** A type of bridle without a bit using a curb chain and metal shanks for leverage.

**Hand:** The unit by which the height of an animal is measured; hand equals 4 inches.

**Header:** Person (adult or 4-H member) who enters the arena for safety purposes while animals are lined up. Almost exclusively seen in driving classes.

**Headstall:** The part of a bridle or hackamore that fits over the animal's head.

**Hobble:** Rope or leather strap used to tie the legs together to restrain an animal.

**Horse:** Any equine over 56 inches tall at the withers.

**Horsemanship:** The art of riding horseback; equitation.

**Jog:** A western two-beat diagonal gait (trot).

**Knockdown:** The causing of any portion of the jump to fall down.

**Lead:** The sequence in which the feet hit the ground at a lope or canter. The correct lead shall mean the inside front leg descends last when working in a circle at a lope or canter, i.e., the left lead is correct when the right rear foot hits the ground, then the diagonal left rear and right front and lastly the left front hits the ground.

**Lope:** A collected western, three-beat gait (canter).

**Mare:** A mature female horse/pony/donkey/mule, 3 years or older.

**Martingale (Running):** A piece of training equipment where the reins are laced through rings attached to the breastplate. The running martingale helps keep the horse from elevating its head by applying pressure on the bit if the head is raised enough that the rings apply downward pressure on the reins.

**Martingale (Standing):** A piece of training equipment in which a strap is used to attach the cavesson to the breast collar. If the horse raises its head beyond the length of the strap, pressure is applied to the cavesson to keep the head down.

**Near side:** The animal's left side.

**Off side:** The animal's right side.

**Pads:** Leather or synthetic piece of material placed between the shoe and the hoof. This may either be a rim pad (just goes under the shoe and the wall, leaving the sole open), or a full pad (covers the entire bottom of the hoof). The term may also be used to refer to the protective pad between the horse's back and a saddle.

**Plates:** A standard shoe approximately 1/4 to 3/8 inch thick without weight added to enhance action. (A standard plate would usually not exceed 14 ounces.)

**Pony:** Any equine 56 inches and shorter at the withers.

**Posting:** The rising and descending of a rider with the rhythm of the trot. Remember the correct diagonal with the axiom, "rise and fall with the leg on the wall."

**Ring steward:** Shall be familiar with the show and contest procedure and etiquette. This person has charge of the activity in the ring or arena and may disqualify exhibitors for failing to control their animals, and endangering self or others. He/she is a mediator between the judge and exhibitor; and must have in mind that he/she is selected to assist the judge, not to advise the judge.

**Roached:** A mane that has been clipped or cut close to the crest of the neck.

**Roadster:** Horse or pony that simulates conditions of a harness race at speed.

**Romal (Rommel):** A long, flexible quirt or braided ends of closed reins.

**Seat:** A term referring to the ability of a rider to sit the saddle with grace and control of his/her mount.

**Showmanship safety zone:** See page 16.

**Show steward:** Individual appointed by the show management to act in the interest of the exhibitor, show management and judges by interpreting the rules without the need of a protest. He/she is not to advise the judge.

**Sire:** The male parent of an animal.

**Slicker:** A raincoat made of oiled canvas or plastic.

**Snaffle bit: Western:** Smooth snaffle bit with broken mouthpiece, minimum 3/8 inch in diameter measured 1 inch in from the cheek piece. Snaffle bits must be such that when reins are pulled, no leverage is applied. See page 34.

**Snaffle bit: Hunter:** A straight or broken mouthpiece bit with no leverage applied. Mouthpiece must not have sharp materials such as screws, cathedrals, donut holes, etc. Mouthpiece may be rubber, copper, twisted wire, etc. but a maximum 3/8 inch in diameter 1 inch in from the cheek piece.

**Sound:** A term meaning the animal is physically fit and shows no signs of weakness or illness.

**Stallion:** A mature male horse/pony 3 years of age and over.

**Stride:** The repeated limb coordination and placement exhibited by the moving horse. The distance and/or time from when a particular foot leaves the ground until that foot again strikes the ground.

**Tack:** Riding equipment or gear for the animal, such as saddle, bridle, halter, etc.

**Tie-down:** A strap connecting the noseband on the bridle (or with a separate headstall and noseband) to the cinch which prevents the horse from throwing its head up. This western version of the standing martingale is not acceptable for use in English classes.

**Touch:** A scoring aid for judging a jumping class; contact with any part of an obstacle without lowering the height of the fence.

**Trot:** A two-beat diagonal gait (jog).

**Walk:** A four-beat gait in which the horse should stride out freely and willingly; true, flat-footed and ground covering.

**Weanling:** A foal, colt or filly, under 1 year old that has been weaned from its mother.

**Weighted shoes:** Any shoe that has weight added to cause animation, usually 1/2 to 1 1/2 inches thick.

**Yearling:** A colt or filly that is at least 1 year old but not yet 2 years old.



## REFERENCES

### **American Horse Council**

1700 K Street N.W.  
Washington, D.C. 20006-3805  
(202) 296-4031  
[www.horsecouncil.org](http://www.horsecouncil.org)

### **American Miniature Horse Registry**

[www.shetlandminiature.com/registries/amhr](http://www.shetlandminiature.com/registries/amhr)

### **American Paint Horse Association**

2800 Meacham Boulevard  
Fort Worth, Texas 76137  
[www.apha.com](http://www.apha.com)

### **American Quarter Horse Association**

AQHA  
P. O. Box 200  
Amarillo, TX 79168  
[www.aqha.com](http://www.aqha.com)

### **American Ranch Horse Association**

PO Box 186  
Nancy, KY 42554  
[www.americanranchhorse.net](http://www.americanranchhorse.net)

### **American Youth Horse Council**

1-800-TRY-AYHC  
[www.ayhc.com](http://www.ayhc.com)

### **eXtension Horses**

[www.extension.org/horses](http://www.extension.org/horses)

### **Florida 4-H Bit Rule Examples and Explanations**

<https://animal.ifas.ufl.edu/youth/horse/documents/BitRules.pdf>

### **Indiana Horse Council**

[www.indianahorsecouncil.org](http://www.indianahorsecouncil.org)

### **National Barrel Horse Association**

[www.nbha.com](http://www.nbha.com)

### **National Reining Horse Association**

3000 NW 10th Street  
Oklahoma City, OK 73107-5302  
(405)946-7400  
[www.nrha.com](http://www.nrha.com)

### **United States Dressage Federation**

PO Box 806680  
Lincoln, NE 68501  
(402) 434-8550  
[www.usdf.org](http://www.usdf.org)

### **United States Equestrian Federation**

4047 Iron Works Parkway  
Lexington, KY 40511  
(859) 258-2472  
[www.usef.org](http://www.usef.org)



It is the policy of the Purdue University Cooperative Extension Service that all persons have equal opportunity and access to its educational programs, services, activities, and facilities without regard to race, religion, color, sex, age, national origin or ancestry, marital status, parental status, sexual orientation, disability or status as a veteran. Purdue University is an Affirmative Action institution. This material may be available in alternative formats.