

What's it all About?

With this project sheet you will learn how to size, build, and display an extension cord. The most important thing for you is to determine what do you need a cord for? Knowing this will allow you to use the charts provided to size the conductors, select the proper insulation and connecting bodies. Questions for you are what is the required voltage, what is the wattage of the load, and what is the operating environment of the load? These factors will help you build a safe and long-lasting cord. It is recommended that you read the entire project sheet before you begin so you can better understand the importance of using the proper materials.

Materials Needed

- A minimum of 20 feet of 12, 14, or 16 AWG junior hard service cord (“Special Purpose” cords may be longer or shorter than 20 feet).
- An appropriately sized dead front plug with cord grip for the size wire used
- An appropriately sized connector body for the size wire used

Tools Needed

- Utility Knife
- Wire Strippers/Cutters
- Screwdriver

For the Project

- Record sheet
- 4-H Exhibit Skills and Knowledge Sheet
- Display cord neatly with ends accessible
- Attach a note explaining its use

Wiring the Cord

1. Remove enough of the outer protective covering of the cord to allow you to wire the plug properly. To do so, cut the outer covering of the cord using a sharp utility knife, be careful not to nick or cut the insulation covering the conductors inside the cord. Repeat the process for the other end of the cord that will receive the connector body. Note at this point that there is a male and female end to a cord. With the proper end of the cord being used with the plug or connector body, the conductors/colors align.
2. Remove the insulation from the end of each wire so that there is just enough bare conductor showing to wrap around the shank of the screw or go into the terminal connection. You may use a sharp knife or wire stripper to remove insulation but be careful not to nick or cut through any of the copper strands.
3. Twist the strands of each conductor together. They should always be twisted in a clockwise direction (when viewed from the cut end) so that the strands will not separate when the wire is secured under the screw head.
4. Slide the connector housing and plug shell over the ends of the wires.
5. The wiring connections inside plugs and connector bodies are normally color-coded. The “hot”

(black) wire should be connected to the gold-colored screw or terminal. The “neutral” (white) wire should be connected to the silver-colored screw or terminal. The grounding (green) wire should be connected to the green-colored screw. If the plug or connector has only screws for making connections, wrap the bare wire around the screw shank in a clockwise direction and tighten the screw. If your plug or connector has terminals, you need only to insert the bare wire straight into the terminal between the flat metal pieces and tighten down the screw terminal.

6. Check to make sure all of the bare conductors are fully under the screw heads or terminals, and that the insulation covers the conductors all the way up to the screw heads or terminals. Be sure that the insulation is not under the screw heads or terminals and that the wire cannot be pulled off or out of the connections.
7. Assemble the plug body and connector body and tighten down the cord clamps on the outer jacket of the cord. Be careful when assembling the plug/connector bodies so as not to pinch and damage the insulation of the conductors.
8. Attach a note to your finished exhibit explaining how you intend to use your extension cord. You may also construct a display for your cord to include with your exhibit.

Three-Prong Plug

A three-prong plug is naturally polarized because it can only be plugged into a “3-wire” electrical outlet (one which uses a grounding wire) one way. Each prong on the plug has only one location that it can fit into on the electrical outlet. It cannot be rotated to fit in any other direction.

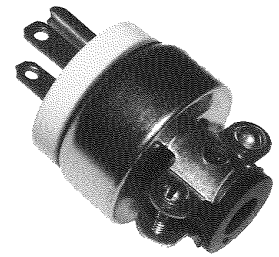

Three-Prong Plug with External Cord Clamp

Connector Bodies

- Connector Bodies are used on one end of an extension cord to allow an appliance to be connected to the circuit. Some connector bodies are “light-duty”. They should be used only on parallel extension cords for connecting low-wattage appliances such as radios, lamps, etc.
- Heavy-duty connector bodies should be used on heavy-duty extension cords for general use and special purpose around the house, shop, and farm.
- The size of a connector body should be matched to the cord size. For heavy-duty cords, use a connector body with a cord grip (clamp) for greater safety. Just like a plug, a connector body must have a strain relief device that prevents the wire from being easily pulled out of the connector body.



Three-Wire Connector Body with External Cord Clamp

Final Note

- Use the Current Carrying Capacity chart on the next page to help you select the correct wire gauge based on your intended use.
- Use the Type Letter Key and/or Table to help you select the proper insulation based on the cord’s intended operating environment.

Reference Charts

Standard Lamp and Extension Cord Current Carrying Capacities

Wire Size AWG	Maximum Current in Amps	
	2-Current Carrying Conductors	3-Current Carrying Conductors
10	30 (24)	25 (20)
12	25 (20)	20 (16)
14	18 (15)	15 (12)
16	13 (10)	10 (8)
18	10 (8)	7 (6)

(Bold values) are the maximum current ratings reduced to provide a 20% safety factor. Use these reduced values for activities in this manual and for any cords you wish to construct! Thus, if you wish to construct an extension cord that handles up to (15) Amps, use 14 AWG wire.

A cord that has three conductors (black, white, and green wires) is considered to be a "2-conductor cord with ground." This is because it has only two "current carrying" conductors. The markings printed on the outer jacket, however, which always indicate the total number of conductors, would read "3." We see from the table above, a 12 AWG 2-Conductor cord with ground is rated to carry up to (20) amps.

NEMA Configurations for Straight Blade and Locking Devices

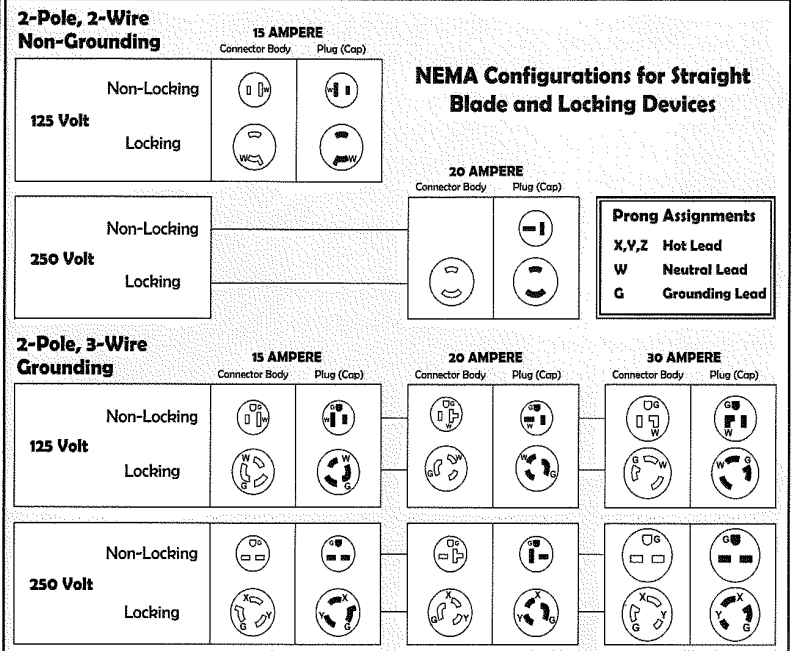

The National Electrical Manufacturers Association (NEMA) has assigned designators to the various configurations. The purpose of so many different types is to prevent the wrong combinations of electrical systems from being plugged together, thereby avoiding potentially dangerous conditions.

Electrical Cord Properties Type Letter Key

- SP, SPT, S, SJ, SV, ST, SJT, SVT
- S** = Service grade (also means extra hard service when not followed by J, V, or P)
- J** = Junior hard service
- P** = Parallel cord (also known as zip cord) - Always light duty
- 1,2,3** = Insulation thickness for parallel cords: 1-thinnest, 3-thickest
- O** = Oil resistant outer jacket
- OO** = Insulation covering conductors and outer jacket insulator are all oil-resistant
- T** = Thermoplastic
- E** = Thermoplastic elastomer
- H** = Heater cable
- N** = Neoprene
- W** = Wet
- D** = Suffix indicating twin wire with two insulated conductors laid parallel under an outer, non-metallic covering
- V** = Vacuum cord/cable

Type Letter	Wire Size (AWG) and Numbers of Conductors*	Carrying Capacity at 120 V (Watts)	Type of Insulation		Approved Use and Location of Extension Cord	
			Around Wires	Outer Coverings		
<i>Parallel</i>	SP-2	18/2 OR 18/3 16/2 OR 16/3	840 1200	Rubber	Rubber	Not hard usage, Dry or damp places; lamps, non-heating appliances
	SP-2	18/2 OR 18/3 16/2 OR 16/3	840 1200	Thermoplastic	Thermoplastic	Heater cords or heating appliances
	HPN	18/2	840	Rubber	Asbestos covered with cotton or rayon braid or rubber	Hard usage; dry or damp places; portable appliances
	HPD	16/2	1200			Hard usage; dry, damp, or oily places; portable appliances
<i>Junior Hard Service</i>	SJ	16/2 or 16/3 14/2 or 14/3 12/2 or 12/3	1200 1800 2400	Rubber	Rubber	Hard usage; dry, damp, or oily places; portable appliances
	SJT			Thermoplastic or Rubber	Thermoplastic	
	SJO			Rubber	Oil Resistant Compound	
<i>Hard Service</i>	S	16/2 or 16/3 14/2 or 14/3 12/2 or 12/3	1200 1800 2400	Rubber	Rubber	Hard usage; dry, damp, or oily places; portable appliances
	ST			Thermoplastic or Rubber	Thermoplastic	
	SO			Rubber	Oil Resistant Compound	

* This first number gives the size of each individual conductor. The number following the slash gives the total number of conductors in the cord. For Example: 14/3 means the conductor size is 14 AWG and the cord has three conductors.