



2022 Fulton County All Projects Summary Guide

-  Mini 4-H Projects
-  General (Non-Walking) Projects
-  Animal Projects

4-H Fair—July 9-16, 2022

I Pledge

my **HEAD** to clearer thinking,
my **HEART** to greater loyalty,
my **HANDS** to larger service, and
my **HEALTH** to better living, for
my club, my community, my country, and
my world.



Purdue University is an equal opportunity/equal access/affirmative action institution.

TABLE OF CONTENTS

List of Leaders and Clubs	3	Health & Well Being	101
Extension & Council Contact Page.....	4	Home Environment.....	121-103
Judging Locations & Times	5-6	Horseman Without Horses.....	104
4-H Record of Achievement form.....	7-8	Junior Leaders	105
Indiana 4-H Policies & Procedures	9-15	Micro Mini Tractor Pulling	106
Grievance/Appeal Form.....	16	Our American Heritage	107
Fulton County General 4-H Rules.....	17-18	Photography.....	108-109
4-H Council Organization	19-21	Poultry: Poultry Science Poster	110
College Choice Savings Program.....	22-23	Rabbit: Rabbit Poster.....	111
Mini 4-H Section	24	Scrapbooking	112-113
Mini 4-H Information & Project List	25-26	Sewing	114-118
4-H Community Building Projects Section.....	27	Shooting Sports	119-120
Fulton Co. 4-H Community Bldg. General Exhibit Rules ..	28	Small Engines	121
Poster Updates	29	Soil and Water Conservation	122
4-H Achievement Record Book	30	Sports.....	123
Aerospace.....	31-32	Sportfishing	124
Arts and Crafts Section	33	Tractor Section	125
Arts & Crafts, General (<i>Now includes Holiday Décor</i>).....	34	Lawn & Garden Tractor Operator Skills	126-127
Construction & Architectural Replica	35	Tractor Safety & Operator Skills.....	128-129
(<i>Formerly Farm Toy & Construction Scene</i>)		Zero-Turn Mower Safety & Operator Skills	130-131
Fine Arts	36	Travelogue	132
Model Crafts	37	Veterinary Science.....	133
Needle Crafts	38-39	Weather and Climate Science	134
Arts & Crafts, General: Gift Wrapping.....	40-41	Welding	135
Arts & Crafts, General: Legos	42-43	Wildlife.....	136
Arts & Crafts, General: Model Railroad.....	44-45	Woodworking	137-140
Arts & Crafts, General: Recycling.....	46	4-H Animal Rules & Requirements.....	141
Arts & Crafts, General: Scarecrow	47	Animal ID Requirements per Species.....	142
Aquatic Science	48	Selection & Responsibilities of Departments & Heads	143
Bicycle.....	49	Livestock Department Heads & Committees	144
Books.....	50	4-H Livestock Sale Guidelines	145
Bottle Rockets	51	Animal Enrollment Deadlines	146
Cake Decorating.....	52-53	Livestock Exhibit General Guidelines	147-148
Cat: Cat Poster	54-55	Supreme Showmanship Rules	149
Child Development	56-57	Fraud & Deception	150
Collections	58	Specific Animals	
Consumer Clothing	59-60	Beef	151-153
Crops (<i>Corn, Hay, Silage, Soybeans, Wheat</i>).....	61	Feeder Calf	154
Cupcake Decorating	62	Cats	155
Do Your Own Thing	63	Dairy.....	156-157
Dog: Dog Poster.....	64-65	Dogs.....	158-161
Electric	66-68	Indiana 4-H Aggressive Dog Policy	162
Entomology.....	69-70	Goats.....	163-166
Fashion Revue.....	71-72	Horse & Pony	167-172
Floriculture.....	73-75	Extreme Challenge	173-175
Foods Baked.....	76-79	Poultry	176-181
Foods Preserved	80-83	Rabbits.....	182-184
Foods—Fun with Food Mixes	84-85	Sheep	185-190
Forestry	86-88	Swine	191-192
Garden.....	89-93	2022 Animal Health Requirements for Exhibition of Domestic Animals in Indiana	193-198
Genealogy	94-98		
Geology.....	99-100		

2021-2022 4-H CLUB INFORMATION

Club	Leaders	Phone #	Location
Aubbee Gamblers Tuesday, 7:00 p.m.	Emily Schouten Erica Rude	574-542-2853 765-480-0689	Leiter's Ford Community Building
Burton Busy Bees Monday, 7:00 p.m.	Scott Burton Jenna Burton	574-551-7559	Fairgrounds—Community Bldg. (CB) or Everett Smith (ES)
Cat's Meow—For those who DO NOT plan on attending meetings. Books will be available in the office and not sent to a leader.		574-223-3397	
Fulton County Bullseyes Monday, 6:30 p.m.	Steve Whistler Brian Johnson Rick Notz Joe Cook	574-223-5019 574-223-9690 574- 260-579-2299	Fulton County Conservation Club (behind Fulton County Museum) or Everett Smith Bldg. or Ringers Outdoors
Fulton County Horse & Pony Tuesday, 6:45 p.m. sign in	Julie Moore Leslie Crissinger	574-505-0042 574-835-0255	Fairgrounds—Community Bldg.
Henry Hardy Farmers Sunday, 4:00 p.m.	Stacey Harsh Kim Backus	574-780-0534 574-505-0056	Tippy Valley Middle School Commons
Liberty Leaders Various days, 7:00 p.m.	Rachel Burns R.D. Burns	574-930-0447 574-201-7330	Fulton Baptist Temple
Model Railroading Sunday, 2:00-4:00 p.m.	Allison Earp Tara Seuferer Scott Seuferer	574-225-2749 574-835-0145 574-835-3755	Model Railroading Club House
Newcastle Nifties Monday, 7:00 p.m.	Letitia Geller Jessica Clauson	574-835-0945 574-835-6760	Jessica's house 4127 E 550 N; Rochester
Reiter Busy Workers Tuesday, 7:00 p.m.			
Richland Clodhoppers/Never Give Up	Betsy Gardner	574-223-6175	
Rochester Ag 4-H Club—for High School Ag Students ONLY	Justin Pearson	574-835-4223	High School during school hours
Wayne Trophy Finders/Wide Awake Sunday, 2:30 p.m.	Tammy Vigar Sandy Rock	574-835-5292 574-230-3833	Grass Creek Fire Station
Woodrow Peppers/Sodbusters Wednesday, 7:00 p.m.	Lee Ann Eizinger	574-223-8137	Fairgrounds—Everett Smith Building

OTHER GROUPS—NOT CONSIDERED A CLUB

Group	Leaders	Phone #	Location
Fulton County Electric Meetings	TJ Garner	574-817-0118	REMC
Fulton County Mighty Mutts Tuesday	LeeAnn Pollock Penny Conover	765-427-3623 574-835-4138	Fairgrounds—Everett Smith Building
Junior Leaders—for 6th through 12th Graders Only Various days & times	Jeannie Rock Beth Cohagan RaeAnn Reichard	574-817-0756 574-223-3515	Fairground—Community Building or Everett Smith

PURDUE UNIVERSITY COOPERATIVE EXTENSION SERVICE

Fulton County

1009 W. 3rd Street
Rochester, IN 46975

www.extension.purdue.edu/Fulton/

Office Hours: Monday-Friday, 8:00 a.m.-4:00 p.m.

Phone: (574) 223-3397

Fax: (574) 223-2386

EXTENSION EDUCATORS:

Mark Kepler
County Extension Director
Agriculture & Natural Resources
mkepler@purdue.edu

Extension Educator
4-H Youth Development

Jessica Riffle
Extension Educator
Health & Human Sciences
jcanned@purdue.edu

ADMINISTRATIVE ASSISTANTS:

Kris Batten
Office Manager
ANR & HHS Secretary
battenk@purdue.edu

Jeannie Rock
4-H Secretary
rock3@purdue.edu

It is the policy of the Purdue University Cooperative Extension Service that all persons have equal opportunity and access to its educational programs, services, activities, and facilities without regard to race, religion, color, sex, age, national origin or ancestry, marital status, parental status, sexual orientation, disability or status as a veteran. Purdue University is an Affirmative Action institution.

FULTON COUNTY 4-H PROGRAM

Rules and guidelines listed for the 4-H program have been approved by the Fulton County 4-H Council. Any recommended changes must be approved by the Fulton County 4-H Council.

4-H COUNCIL OF FULTON COUNTY, INC.

The purpose of the 4-H Council of Fulton County, Inc. is to help plan and implement a 4-H program that is consistent with the mission of Purdue University Cooperative Extension Service. The program should offer a variety of high-quality 4-H youth educational opportunities, be adequately supported, and be in line with the developmental needs of young people.

2021-2022 4-H Council Executive Members:

- Ron Clauson.....President
- Rick Rock..... Vice-President
- Jenny Stiffler.....Secretary
- Sandy Owens.....Treasurer



2022 Judging Locations & Times



Tuesday, June 28, 2022—5:00-7:00 p.m.—Community Building

- Aerospace
- Books
- Bottle Rockets
- Cat Poster
- Child Development
- Dog Poster
- Entomology
- Forestry
- Geology
- Health & Well Being
- Horseman w/o Horses
- Photography
- Poultry Poster
- Rabbit Poster
- Sewing
- Shooting Sports
- Small Engines
- Soil & Water
- Sports
- Sport fishing
- Tractor Poster
- Travelogue
- Vet Science
- Weather
- Wildlife

Tuesday, June 28, 2022—5:00-7:00 p.m.—Everett Smith Building

- Foods, Baked
- Foods, Preserved
- Fun with Food Mixes

Wednesday, June 29, 2022—9:00 a.m.—Community Building

- Achievement Record Books
- Genealogy

Wednesday, June 29, 2022—Everett Smith Building

12:15 p.m.—Consumer Clothing Notebook Judging

12:30 p.m.—Fashion Revue Registration

1:00 p.m.—Fashion Revue

Consumer Clothing—Fashion Revue—Following the Fashion Revue, garments modeled are to be turned in at the 4-H Community Building for exhibit. Consumer Clothing notebooks will be on display in the Community Building.

Wednesday, June 29, 2022—5:00-7:00 p.m.—Community Building

- Arts & Crafts, General
- Cake Decorating
- Collections
- Construction & Architectural Replica
- Cupcake Decorating
- Do Your Own Thing
- Fine Arts
- Gift Wrapping
- Holiday Decorations
- Home Environment
- Legos
- Model Railroading
- Models
- Needle Crafts
- Recycling
- Scrapbook
- Welding
- Woodworking

Wednesday, June 29, 2022—6:00 p.m.—Everett Smith Building

- Micro Mini Tractor Pulling Judging

Thursday, July 7, 2022—6:00 p.m.—Jud Hudkins Arena

- Dog Agility

Friday, July 8, 2022—Everett Smith Building

- 8:30 a.m.—Electric
- 10:00 a.m.—Aerospace and Bottle Rocket launch outside the Everett Smith Building
- 6:00 p.m.—4-H & Mini 4-H Cat Show

Saturday, July 9, 2022—Project Judging

- 8:00 a.m.—Dog Obedience & Showmanship—**Hudkins Arena**
 - 9:00 a.m.—Crops—**Quonset Building**
 - 9:00 a.m.—Our American Heritage Judging—**Quonset Building**
 - 9:00 a.m.—Floriculture
Garden
Scarecrow
Mini 4-H Non-Walking Exhibits
- Community Building**
- 10:00 a.m.—Aquatic Science—**Community Building**
 - 10:00 a.m.—4-H Tractor, Lawn and Garden, and Zero Turn Tractor Contest—**Fairgrounds Parking Lot**

Saturday, July 16, 2022—9:00-11:00 a.m.—Community Building

Release all 4-H Exhibits not going to the State Fair. **Be sure to bring your 4-H Achievement Record Sheet filled out on BOTH SIDES.**

Animal Check-in and Judging

Saturday, July 9	7-10 p.m.	Swine check-in
Sunday, July 10	11:00-1:30	Beef, Feeder Calf & Dairy check-in/weigh-in
	Noon-2:00	Poultry check-in
	1:00-6:00	Horse & Pony check-in
	2:00-4:00	Sheep check-in
	4:00-5:00	Goat check-in
	4:00-6:00	Rabbit check-in
	7:00 p.m.	Community Building Awards Program—Jud Hudkins Arena
Monday, July 11	8:30 a.m.	Horse & Pony—Showmanship & Halter Classes followed by Trail Class
	9:00 a.m.	Poultry Show—Mini 4-H followed by 4-H Classes & Showmanship—Poultry Barn
	9:30 a.m.	Dairy Show—Mini 4-H followed by 4-H—Hudkins Arena
	12:30 p.m.	Sheep Show—Mini 4-H followed by 4-H—Hudkins Arena
	6:30 p.m.	Horse & Pony—Equitation Classes
Tuesday, July 12	8:00 a.m.	Rabbit Show—Mini 4-H followed by Rabbit Showmanship—Rabbit Barn
	1:00 p.m.	Beef Show—Includes Dairy Beef, Feeder Calves, & Mini 4-H—Hudkins Arena
	4:00 p.m.	Horse & Pony—Western Classes
Wednesday, July 13	8:00 a.m.	Swine Show—4-H in the morning; Mini 4-H first class after lunch—Hudkins Arena
	4:00 p.m.	Horse & Pony—4-H Costume Class and Mini 4-H Show
	10:00 p.m.	Release Swine not in the sale or carcass show
Thursday, July 14	8:30 a.m.	Goat Show—Includes Dairy, Boer, Meat, Pygmy, Market & Mini 4-H
	5:00 p.m.	Horse & Pony—Grand Entry, Awards, Fun Show
	5:00 p.m.	Supreme Master Showmanship—Hudkins Arena
	10:00 p.m.	Release 4-H Horse & Pony and 4-H Livestock NOT in the sale
Friday, July 15	5:00 p.m.	Livestock Auction—Hudkins Arena
	7:00 p.m.	Grand Champions Spotlight Sale—Hudkins Arena
Saturday, July 16	6:00 p.m.	Swine Carcass Show—Hudkins Arena



4-H Point Schedule

		✓ or #	Points	Points Earned
Points per Year				
Fashion Revue--Sewing	County		10	
	State		20	
Fashion Revue—Consumer Clothing	County		10	
4-H Council Fish Fry Shift	County		10	
Club Offices	Local (club)		10	
	County (Jr. Leaders)		10	
Ag and Lawn/Garden Tractor Operator's Contest	County		10	
	Area		20	
	State		30	
Horse & Pony Fun Show	County		15	
Dog Fun Show	County		15	
Fair Project Check-In or Judging Assistant	County		10	
Fair Project Check-Out Assistant	County		10	
Points per Project, Committee, Demonstration, Etc.				
Project advances to state fair (including livestock) Livestock should be counted by project not per animal.	State		20 per project	
Grand Champion	County		20 per project	
Reserve Grand Champion	County		10 per project	
Showmanship Participant (per species)	County		5 per species	
	State		5 per species	
Showmanship Winner	County		10 per species	
	State		20 per species	
Master Showmanship Winner	County		20 per species	
Serving on a Committee (<i>examples of county would be committee for Jr. Leaders; area would be committees at camp</i>)	Club		5 per committee	
	County		10 per committee	
	Area		15 per committee	
4-H Demonstrations & Public Speaking	Local (club)		15 each	
4-H Judging Event /Career Development Event (Do not include FFA), Soils, Forestry, Livestock, etc. <i>You are part of a 4-H team at these events.</i>	Area		20 each	
	State		30 each	
4-H Promotion Events (post 4-H picture on Facebook, wear shirt, send thank you to leader, random act of kindness 4-H related) Represent 4-H in one of the local area parades.			5 each (maximum 4 events per year for total of 20 pts.)	
Community Service with your club 4-H related (<i>example: recycling with your club, Christmas shopping & Easter Egg Hunt for kids with Jr. Leaders, etc.</i>)			10/each time	
4-H Band, Chorus, Science Trip, Round-Up, Ambassador, 4-H Camp, 4-H Camp Counselor			30 each	
National Activities/Events (<i>National Youth Congress, Tractor Driving Contest</i>)			50 each	
Points Everyone Can Earn—(529 College Choice will be based on the following also):				
Projects Completed (<i>10 pts. x # of projects completed</i>) Livestock should be counted by project not per animal.			10 per project	
Workshops (Spark Clubs, project, livestock, judging/CDE, other county, area, or state workshop that is 4-H affiliated. (<i>Dog meetings, Electric meetings, H & P clinics, Animal workshops, YQCA training, and Tractor are included here because they are not clubs</i>))			5/each (maximum 10 workshops or events per year for total of 50 pts.)	
Club Meetings Attended (<i>includes regular club meetings, Jr. Leaders, & H & P meetings</i>)			5 each	
Fair Clean-Up (Pre-fair or after shows)			10 each (max. 3 per year for total of 30 pts.)	
Total Points Earned				



The Indiana 4-H Program Philosophy and Expectations

The Indiana 4-H Youth Development program serves the youth of Indiana by providing a strong educational youth development program. This program delivers educational experiences in a variety of settings. Caring, capable and contributing adults assist in the 4-H program as models for young people. The rich heritage of the 4-H Program is one to be valued and passed along to future generations.

The Indiana 4-H Youth Policy and Procedures Handbook sets out certain standards and guidelines to be used to assure that 4-H is a positive youth development program. County 4-H policy is guided by the county 4-H policy making or governing board (i.e., 4-H Council) as provided by the County Extension Board. Legal authority for the 4-H Program rests with the Director of the Cooperative Extension Service at Purdue University. No county 4-H policy may conflict with state 4-H policy or with federal guidelines and requirements.

Deadlines for county and state participation should be carefully constructed so as to encourage rather than to discourage participation. Such deadlines should be well published. Members not complying with established and published dates and deadlines for exhibition may be denied the opportunity to exhibit.

It is the policy of 4-H to be an inclusive organization. No county policy or practice should be used to arbitrarily exclude youth from either membership or participation. Youth should participate in 4-H Youth Development opportunities at levels and times that best suit the youth's development and support family involvement.

Per state and federal guidelines, volunteers and Extension Educators may not require youth to attend 4-H club meetings in order to complete 4-H or exhibit their work.

4-H Mission and Vision

***4-H Mission:** The Indiana 4-H Youth Development mission is to provide real-life educational opportunities that develop young people who positively impact their community and world.*

***4-H Vision:** Indiana 4-H Youth Development strives to be the premier, community-based program empowering young people to reach their full potential.*

4-H Club Membership

Youth may become 4-H members when they enter the third grade and may continue their membership through the completion of Grade 12. Each individual may continue membership for a maximum of ten (10) consecutive years.

Exceptions:

- (1) Youth who enroll in Grade 3 and are advanced academically (thus graduating early) may continue for a total of 10 years ONLY if the enrollment occurs in consecutive years.
- (2) Those youth who are academically advanced and “skip” third grade, may begin the program as a 4th grader and may continue for a total of 10 years ONLY if the enrollment occurs in consecutive years.
- (3) Those youth who enroll in Grade 3 and are retained a grade in school may continue to progress through the 4-H Program by adding subsequent years of participation, but MAY NOT exceed 10 years of participation. For example, if a member is retained one year in school (public, private, or home), their final year of 4-H membership would conclude the summer following their junior year of high school.
- (4) Those youth who entered the program in 3rd grade and for one reason or another leave formal education prior to the completion of 12th grade may continue for a total of 10 years ONLY if the enrollment occurs in consecutive years.

NOTE: Ten years of membership in the 4-H Youth Development Program is an opportunity—not an entitlement. Those youth who do not enroll as 3rd Grade students or meet the exceptions above, conclude their involvement with the program during the summer immediately following the completion of their senior year in high school.

An individual's 4-H grade is determined by the school grade in which he or she is classified at the time of year he or she enrolls in 4-H. A member does not advance in 4-H grade until he or she enrolls in 4-H for the subsequent year. Each member should enroll in the division of the project/subject that would best suit his/her interest and potential for personal growth and would enhance their family involvement.

Opportunities in the 4-H program are available to all Indiana youth as defined regardless of race, religion, color, sex, age, national origin or ancestry, marital status, parental status, sexual orientation or disability. Married young men and women of 4-H age may participate in any of the 4-H projects and activities. However, married persons must participate by the same terms and conditions and/or guidelines as unmarried participants. Membership in 4-H is gained by annually enrolling through a Purdue University Cooperative Extension Service Office located in each of Indiana's 92 counties.

The Indiana 4-H Youth Development program year is October 1 to September 30 annually. Enrollment is an annual process attained by completing individual 4-H enrollment via the 4-HOnline enrollment process. Statewide 4-HOnline enrollment occurs annually October 1 through January 15.

Mini 4-H Non-Competitive Policy

Mini 4-H is a program designed to encourage positive development of children, Kindergarten through second grade. The goal of Mini 4-H is to help young children explore friendships outside the family; explore the way in which things work; practice both small and large muscle control; and think about the ways people work together on projects.

The NON-COMPETITIVE learning environment for Mini 4-H includes:

1. Planned learning activities in which children are invited to be active and explore materials and ideas without the pressure of completing a specific product or exhibit.
2. Low adult/leader to child ratio that allows time for adults/leaders to provide individual, positive encouragement and assistance.
3. Simple, interesting activities that are fun.
4. Encouragement of children to participate in a group activity by sharing and or displaying their activity projects.
5. Rewards that are identical and/or ribbons of the same color for everyone.

DO NOT JUDGE projects, but instead discuss them with the child.

NOTE: Purdue University and the Indiana 4-H Youth Development Program do not support, endorse, or encourage 4-H programming for children prior to Kindergarten. 4-H Youth Development Extension staff members and 4-H Volunteers may not offer, or encourage others to offer, programming for children prior to Kindergarten.

Statements for 4-H Enrollment:

There is an annual formal enrollment process for each young person who chooses to participate in the 4-H program. The following statements will appear on EVERY county’s online and paper 4-H enrollment forms. Statements should be printed in such a manner that a box for parent initials appears next to each statement, thus affording the opportunity for a single signature (see sample below). The photo consent statement is optional. [4-H members 18 and over are considered legal adults and sign parent/guardian statements.]

Liability Release Statement:

Initial here
***required**

I understand that participating in 4-H activities can involve certain risks to my child. Those risks may include injury or harm, including, but not limited to, bodily injury, disability, exposure to COVID-19 and other viruses and or illnesses, and death. During virtual 4-H activities, I understand that program staff are not providing supervision for my child during the online program, and the Released Parties do not have control over the information available through the internet or other electronic data sources beyond that which is a part of the 4-H activity. On behalf of my child, I fully assume the inherent risks associated with my child participating in 4-H activities and assert that my child has chosen to participate in this program with my express approval. I hereby release and discharge Purdue University, The Trustees of Purdue University, the _____ County Commissioners, the _____ County Cooperative Extension Service, and each of their trustees, officers, appointees, agents, employees, and volunteers ("Released Parties") from all claims which my child or I might have for any injury or harm to my child, arising out of my child’s participation in any activity related to the 4-H program, even if such injury or harm is caused by the negligence or fault of any of the Released Parties. I do not, however, release these individuals and entities from liability for intentional, willful or wanton acts and this release shall not be construed to include such acts.

Parent/Legal Guardian Statement:

Initial here
***required**

I (we) understand, agree to abide by, follow, and comply with the rules, policies and expectations of the 4-H program and will conduct myself (ourselves) in a courteous and respectful manner by exhibiting good sportsmanship and being a positive role model for youth. I (we) also understand that failing to do so will constitute grounds for sanctions against and/or dismissal of me (us) and/or the member from the program.

Parent/Guardian Signature Required

Member Statement:

I agree to follow the rules, policies and expectations of the 4-H program and will conduct myself in a courteous and respectful manner by exhibiting good sportsmanship and good behavior. I understand that failing to do so will result in sanctions, discipline, and/or dismissal from the program.

I agree to follow the rules, policies and expectations of the 4-H program and will conduct myself in a courteous and respectful manner by exhibiting good sportsmanship and good behavior. I understand that failing to do so will result in sanctions, discipline, and/or dismissal from the program.

4-H Member Signature (required)

Photo Policy Statement: (optional on enrollment form)

I (we) grant permission to the 4-H Youth Development program to use videos or photographs of my (our) child for educational purposes or promotion of 4-H and/or Purdue Extension programs.

I (we) grant permission to the 4-H Youth Development program to use videos or photographs of my (our) child for educational purposes or promotion of 4-H and/or Purdue Extension programs.

Parent/Guardian Signature (required)

4-H Enrollment Policy Statement:

We are excited that your family has opted to join Indiana's premiere (and largest) youth development program and look forward to working with your family to provide an excellent educational experience for the 4-H members.

Via the 4-H Online Enrollment Center, youth may enroll in the Indiana County 4-H Program of your choice. (Enrollment typically occur in the county of residence). There is an annual \$15 per person State 4-H Program fee. For your convenience, you will have the option of paying the fee online with a credit card or paying in person with personal check or cash at your local Purdue Cooperative Extension Service Office. Some county 4- programs charge an additional county 4-H Program fee which may also be conveniently paid online.

An individual child's 4-H enrollment will be considered complete once the required signatures/permissions have been submitted and respective fees have been paid.

Residence:

Indiana youth typically enroll in 4-H Youth Development programs in the county or state in which they reside. However, individuals living in one county may join 4-H in another county. There may be educational or social reasons for an individual joining 4-H in a different county than that of their primary residence. During a single calendar year, a 4-H member enrolled in a given project is expected to enroll and exhibit that project only in one county of enrollment.

In the event that a project is not offered in the county of primary 4-H enrollment, a 4-H member may enroll in that specific project in a different county. Approval of this special exception rests with the Fulton County 4-H Council and/or Extension board of the receiving county. Participation in 4-H related activities and events (i.e., judging, share-the-fun, auction) must be in the county of primary 4-H enrollment.

The above policy is not intended to provide an escape mechanism for 4-H members and families who are unwilling to follow the terms and/or conditions in their current county of 4-H membership. Decisions regarding 4-H membership in a non-resident county (a county you do not live in), rest with the 4-H Extension Educator in the receiving county.

Note: In a statement from our federal partner in Washington, D.C., the following statement appears: *"Anytime there are procedures for exclusion of individuals from events which use the 4-H name there are potential challenges to enforcement of the exclusions. The challenges have a substantial potential to prevail and they frequently result in negative publicity for the organization. Therefore, before choosing a policy of exclusion it is wise to evaluate the exclusion being considered, to be sure there is an overwhelming educationally based need for the exclusion."*

Extension employees and volunteers are obligated to eliminate (and should not create) any practices that limit, deprive, or tend to deprive any youth of opportunities for membership and/or participation in the Indiana 4-H program.

Behavioral Criteria for 4-H Events and Activities

To 4-H members, volunteers, parents and the public: When attending, participating or acting on behalf of the 4-H program, all persons are expected to conduct themselves in accordance with accepted standards of social behavior, to respect rights of others, and to refrain from any conduct which may be injurious to the 4-H program. The following actions constitute misconduct for which persons may be subject to disciplinary consequences and/or dismissal from the program:

- (a) Dishonesty in connection with any 4-H activity by cheating or knowingly furnishing false information.
- (b) Alteration or unauthorized use of 4-H records.
- (c) Obstruction or disruption of any 4-H activity or aiding and encouraging other persons to engage in such conduct.
- (d) Failure to comply or aiding or encouraging other persons not to comply with specific terms and conditions of a given project, contest, or activity.
- (e) Failure to comply with directions of 4-H officials acting in the proper performance of their duties.
- (f) Inhumane treatment of 4-H animal projects.

There are many opportunities for 4-H members, volunteers, parents and the public to participate in 4-H events and activities. When involved in such experiences, members, volunteers, parents and the public are expected to follow all rules and regulations as outlined by those responsible for the specific program or activity. In all such 4-H activities, the following constitute a violation of behavioral expectations:

1. Possession or use of fire crackers, gun powder, firearms, chemicals or other materials that can be used to create an explosive mixture.
2. Misuse of fire equipment or sounding a false fire alarm.
3. Having a guest of a different gender in your sleeping quarters, or inappropriate sexual behavior.
4. Physical or verbal abuse of any person or conduct which threatens or endangers the health or safety of any person.
5. Theft of or malicious damage to property.
6. Possession, use, or distribution of alcohol, illegal drugs, tobacco and tobacco-like products, or other dangerous substances.
7. Inappropriate displays of affection towards another person(s).
8. Distribution, misuse, or abuse of over-the-counter, homeopathic (including supplements and vitamins), or prescription medications.
9. Inappropriate clothing or lack of clothing during the event or activity.
10. Lewd, indecent, or obscene conduct or language.
11. Unauthorized entry, use or occupancy of any facility.
12. Any conduct which threatens or interferes with maintenance of appropriate order and discipline or invades the rights of others.
13. Unwillingness to follow appropriate health and safety procedures.
14. Reckless or inappropriate behavior.

When violations occur at out-of-county, district, area, state and/or national 4-H events, the following procedures will be followed:

- (a) The parents/legal guardians may be contacted to arrange transportation home for the violator(s) and
- (b) The local extension educator may be notified.

I verify that I am a 4-H member, I have read and will abide by the rules and behavioral expectations, set by the Indiana 4-H program or I will forfeit my right to stay. Both signatures are required.

4-H member Signature _____ Date _____
 Parent/Legal Guardian Signature _____ Date _____

(Attach 4-H member's recent photo to back of this form).

Guidelines for Exhibition and Completion of 4-H Projects:

Exhibition: Exhibition of 4-H projects/subjects in local, county, or state exhibits/fairs, in person or virtually, is voluntary on the part of the exhibitor. The exhibition of 4-H projects/subjects provides 4-H members an opportunity to display their 4-H projects/subjects, enter into competition, and participate in an educational/social environment with peers. With exhibition also comes the responsibility for abiding by all the terms and conditions pertaining to the respective 4-H project.

Completion: The completion of a 4-H experience may include a variety of options and must not be misinterpreted solely as exhibition of a project at a local, county, or state fair. There are a number of ways that a young person may participate in the 4-H Youth Development Program in addition to the club-based option. Participating in these 4-H opportunities enable the youth to build skills that will serve them well throughout their adult lives.

Some of these participation options do not include the preparation of a specific exhibit by an individual that would be on display at a fair or similar event. In some cases, the youths' actual participation may be the final product that results in their completion of a year of 4-H. Some examples of this participation include working as a team to develop a robot for a workshop or challenge; completing a Spark Club experience; participating in State 4-H Band or Chorus; taking part in a science training or experiment; participating in an after school 4-H experience; etc.

4-H members are considered complete in their 4-H educational experience for the year when they have (1) completed the 4-H member enrollment process prior to the established and published date for enrolling; and (2) had an officially recognized 4-H volunteer/Extension Educator verify the existence of the completed project/subject or the member's participation in a 4-H educational experience—this could be in the form of an exhibit, poster, report, presentation, etc. Or, a member may choose to submit a completed record sheet in lieu of an exhibit to complete the club- or fair-based

4-H project/subject. The 4-H record sheet will be based on printed or web-based educational materials (used by Indiana 4-H Youth Development) and submitted prior to the established and published date.

Though exhibiting in local, county, and state exhibits/fairs is not required for project completion, as it does not necessarily relate directly to content and skills learned in the development of the 4-H project, project exhibition is encouraged as a continuation of the educational experience.

Extension employees and volunteers are obligated to eliminate (and should not create) any practices that limit, deprive, or tend to deprive any youth of opportunities for membership and/or participation in the Indiana 4-H program.

Per state and federal guidelines, volunteers and Extension Educators may not require youth to attend 4-H club meetings in order to complete 4-H or exhibit their work.

Guidelines for Animal Exhibits: Each 4-H member shall own his/her 4-H exhibit. Ownership, personal possession, and regular care of the animal must be in effect on or before the county and state enrollment deadlines and continuously until after the 4-H show at the county and/or state fair.

1. **For 4-H breeding animals:** family corporations and/or partnerships of 4-H members with one or more parents, siblings, grandparents, aunts, uncles, or legal guardians are acceptable.
2. **For 4-H dairy cattle:** family corporations and/or partnerships of the 4-H member with unrelated persons or dairy operations are also acceptable.
3. **Dairy heifers, horses, ponies, alpacas and llamas** may be leased subject to approval of both the county 4-H dairy, horse and pony, or llama committee and the respective County Extension educator. 4-H animals (horse and pony, dairy, alpacas and llamas) are only eligible to be leased by a single 4-H member in a 4-H program year.
4. **4-H animals** are expected to be in the possession and regular care of the 4-H member who owns/leases them (unless other arrangements have been agreed upon by the County 4-H Extension educator) from the animal ID deadline until the conclusion of the county and/or state fair.
5. **4-H market animals and commercial animals** must be individually identified and verified under the supervision of the county 4-H program at county identification events by May 15th. These species include market lambs and commercial ewes, dairy wethers, dairy feeder steers, dairy beef steers, beef steers, market and commercial heifers, meat goat wethers, and market wether dams.
6. **4-H animals purchased, sold or offered for sale after the ID deadline and prior to the Indiana State Fair (including animals that have gone through a “Premium Only auction”)** shall not be eligible to show in the 4-H show at the Indiana State Fair. Sale of products of animals (milk, cheese, wool, etc.) in lieu of the animal, are considered equivalent to a “Premium Only Auction.”
7. **4-H animals exhibited after the May 15 State 4-H animal ID deadline at any show by anyone other than the individual whose 4-H enrollment record is connected to the ID of the animal in Indiana 4-H Online** will not be eligible to be shown in the 4-H show at the Indiana State Fair. This term/condition does not apply to siblings and parents, who may show each other’s animals at any show during the year without jeopardizing State Fair eligibility. 4-H animals that are selected by 4-H Extension Staff or 4-H Adult Volunteers for use in supreme showmanship contests (Master Showmanship, Round Robin etc.) may be used in those county events without jeopardizing State Fair eligibility. This policy applies to all 4-H animal projects. For animal projects without state ID deadlines, the person who enters them in the Indiana State Fair 4-H show is the equivalent of the owner of the animals.
8. **Temporary guardianships** established for the intent of animal exhibition or grooming purposes are not permitted and shall result in immediate disqualification.

Grievance/Appeal Guidelines for County 4-H Program Issues (Activities, Programs, Projects)

The grievance procedures outlined in this document are utilized as part of an internal process of the Indiana 4-H Youth Development program when grievances of 4-H members, their parents/guardians, or 4-H volunteers cannot be resolved via reasonable conversation. This policy affords the opportunity in those unique situations to allow voice or opinion to be heard when there is a dispute regarding 4-H participation, activities or programs. **This is not a mechanism for complaints against individual 4-H members (or their families), 4-H volunteers, judging officials for competitive events, or Purdue Extension staff.** All resulting decisions will be made in accordance with the Indiana 4-H

Program's stated mission to be an inclusive organization designed to encourage and maximize youth participation. The rights of the individual filing the grievance are limited to those provided by Indiana 4-H Program policy.

Purdue University, as the Land Grant University in Indiana, is charged (by the United States Department of Agriculture) with implementing the 4-H Program in communities across the State of Indiana. Purdue Extension Educators in each Indiana county represent the university in local communities and have the responsibility of assuring all 4-H volunteers meet basic university criteria as they serve as representatives of the University. Purdue Extension Educators additionally provide oversight to 4-H volunteers including the assurance that Indiana 4-H Policies and Procedures are appropriately implemented in 4-H Program delivery.

Individual county 4-H policies and procedures should be created and reviewed to assure they do not contradict established statewide 4-H policies and procedures. If a contradiction is discovered during the grievance process, Indiana 4-H Program policy shall be followed in determining the grievance outcome.

1. Grievances are made by completing the Indiana 4-H Grievance/Appeal form with the burden of proof being the responsibility of the individual filing the grievance. The completed grievance/appeal form and supporting documentation shall be presented to the president of the 4-H policy-making body (e.g., 4-H council) or the Purdue Extension Educator who works with the 4-H Program. (NOTE: concern regarding staff, volunteers, members, or other individuals are not issues for which a grievance may be filed. 4-H volunteers are assigned by the 4-H Extension Educator. Concerns regarding 4-H volunteers, members, or other individuals should be addressed directly with the Purdue 4-H Extension Educator.)
2. Grievances pertaining to 4-H activities, programs or projects shall be filed with 14 days of an incident or occurrence. Grievances pertaining to county fair related issues are often time-sensitive and must be filed within 24 hours of the incident.
3. The grievance process occurs in the county where the issue or concern arises and offers three opportunities for a concern to be heard and reviewed.
 - a. The grievance is initially heard by an unbiased representative grievance sub-committee of approved 4-H Volunteers. It is the Purdue Extension Educator assigned to 4-H Programming who shall annually work with the chair of the county 4-H Council to determine this committee's membership to include a combination of 3-6 of the following individuals: one representative of the 4-H Council; two 4-H volunteers serving as a 4-H club organizational leader; one member of the County Extension Board; one 4-H volunteer knowledgeable in the subject matter (project) of concern (this individual will vary dependent on the issue raised with the grievance); and up to three community leaders. The Purdue Extension Educator assigned to 4-H shall convene the group.
 - b. The person filing the grievance may appeal the decision of the grievance sub-committee to the 4-H policy-making body, which will then review the facts in evidence and render a decision.
 - c. The person filing a grievance may appeal a decision of the 4-H policy-making body to the County Extension Board. The Extension Board will review the facts in evidence and render a decision. **This is the FINAL LEVEL in the appeal process.**

****While there is no doubt some overlap in who serves on these committees, the intent of a three-level process is to assure different individuals have the opportunity to hear and act on the grievance. ALL individuals involved at any level of the grievance procedure are reminded of the importance of keeping discussions regarding grievances confidential. To maintain the confidentiality of the parties involved, the grievance hearings at each level will be closed to the public. Only the individuals who have filed the grievance, the members of the grievance committee, and the Purdue Extension Educators will be present during each level of the grievance process. ***The grievance process is internal to the Indiana 4-H Youth Development Program and meetings of the grievance committees are not subject to Indiana's Open-Door Policy.**

The Purdue Extension Educator assigned to work with the 4-H Program has the obligation to inform all parties that there is a grievance procedure if there are disagreements with policies.

The practice of charging fees from those filing grievances shall be eliminated and all counties will utilize the Indiana 4-H Grievance/Appeal Form as part of the grievance process.

Indiana 4-H Grievance/Appeal Form

WARNING: You must read and initial this section before proceeding to complete this document.

- ___1. I understand and agree that filing a grievance that alleges
 - A. facts that are not true, or
 - B. facts that I know are not true, or
 - C. facts I should know are not true:
 will be considered a violation of the 4-H behavioral expectations.

- ___2. I understand and agree that all statements made herein by me are subject to the pains and penalties of perjury and I hereby affirm that my statements herein are true.

- ___3. I understand that perjury is a crime in Indiana.

I, the undersigned, allege that the following term(s) and condition(s) have been violated:

The facts which support this allegation are set out as follows:
(If needed, additional sheets may be attached.)

I swear or affirm under the penalties of perjury ⁽¹⁾⁽²⁾ that I have read, understand, and accept the above statements to be true, accurate, and complete.

Signed: _____ Date: _____ Time submitted: _____

Print your name: _____

Address: _____

Phone: _____

Oath ⁽³⁾

Before me, _____ A Notary Public in and for _____ County, State

of Indiana, personally appeared _____ and he/she being first duly sworn by me upon his/her oath, says that the facts alleged in the foregoing instrument are true.

(signed) _____ My commission expires: _____

(SEAL)

- 1. Perjury –making a false, material statement under oath or affirmation, knowing the statement to be false or not believing it to be true. In Indiana, a person who commits perjury commits a Level 6 felony, ⁽⁴⁾ which may be punishable by imprisonment, fine, or restitution (Indiana Code 35-44.1-2-1 and 35-50-2-1)
- 2. Prosecution for violations of Indiana law will be referred to the proper authorities.
- 3. Oath – An affirmation of truth of a statement before an authorized person.
- 4. Felony – A crime of graver or more serious nature than those designated as misdemeanors.

General Terms and Conditions

Revised 1/18

FULTON COUNTY GENERAL 4-H RULES (Revised 2021)

1. All 4-H & Mini 4-H members are encouraged to enroll by January 15. **The \$15.00 program fee for each 4-H member (with a maximum of \$45.00 per family) must be received before enrollment is considered complete. If these fees are not paid:**
 - ☼ Livestock exhibitors will not be eligible to participate in the livestock auction.
 - ☼ General project exhibitors will receive a participation ribbon and their entries will not be eligible to compete at the Indiana State Fair.
 - ☼ Please see **4-H LIVESTOCK AND ANIMAL PROJECTS GENERAL RULES for livestock enrollment form policy.** This is found in the Animal Section of the All Projects Summary guide for Fulton county which in on <http://v2.4-honline.com>
2. All 4-H members and their parents are responsible for the individual enrollment form. This includes all projects signed up for and any and all changes to the enrollment form with a drop/add form. **This must be done online using 4HOnline. (If you do not have access to the internet please contact the Extension Office for assistance.)**
3. 4-H members can only exhibit the project or projects in which they are properly enrolled. **4-H members must come in to the Extension Office or log on to their online enrollment account by May 15th to drop or add 4-H projects.**
4. A Fulton County 4-H member must join one (1) 4-H club to exhibit in any 4-H project.
5. **All 4-H members and their parents are responsible for entering their projects into the correct division and creating a description of the project using the Fairentry.com system by June 10th in order to ensure a smooth judging process.**
6. All general project exhibits will be judged in advance of the Fulton County 4-H Fair. Each 4-H member should try to be present when his/her exhibit is judged.
7. All exhibits will be required to be in place at the time designated in each individual project requirements.
8. All exhibits must be prepared during the current 4-H club year which is from **October 1—September 30 of the current 4-H year.**
9. Project guidelines will be found under the 4-H project listing in the Community Building Project Requirements section of the All Project Summary Guide.
10. Record sheets and projects that require activities out of a project manual as part of the exhibit guidelines
11. (as indicated in the specific project rules) must be checked in and checked at the time of judging. After check-in is complete the 4-Her will receive their record sheet back. If a record sheet or a required manual are not with a project when it is checked in, it can automatically be dropped & placed.
12. For every 4-H member a **4-H Record of Achievement form (with points on the back) is to be turned in, the last Saturday of the county fair when projects are picked up. This form must be turned in for a 4-H member to receive awards and Promise points.** Any state fair additions may be added later. (A sample is found on page 7 & 8).
 - ☼ Completion of activities in project books for general projects is highly recommended. **The exception to this is for projects that require activities in the manual for State Fair.**
 - ☼ For **animal projects**, record sheets must be completed and submitted to the species committee within 24 hours of check-in in order to show your animal at the county fair.
13. **General Project Policy**
 - ☼ **Check-out will be on the last Saturday of the fair from 9:00-11:00 a.m.** Exhibits may not be taken prior to release except through special permission from the 4-H Extension Educator or Community Building Department Head.

14. **Animal Release Policy**

- ✿ An animal or animals may be released prior to the official release time due to health and/or safety issues/concerns at the discretion of that project’s Department Head or Assistant.
- ✿ It is recommended that the Department Head communicate the situation to his/her committee members prior to releasing the animal or animals AND notify the Extension Educator 4-H Youth Development after the decision has been made.
- ✿ If there is a need to have early dismissal of multiple animals from a barn or department (i.e. weather, disaster, etc.) a committee will meet and discuss the situation and make the final decision. The committee includes: Fulton County 4-H Council President and Vice President, Fulton County 4-H Fair Association Chairperson and Vice Chairperson, All Animal Department Heads and Extension Educators for 4-H Youth Development and Agriculture Natural Resources. Any member may delegate a proxy if needed.
- ✿ Prior to the fair youth may seek permission from the 4-H Council to remove their animal early by submitting in writing a request. This will only be granted under special circumstances and will be reviewed on a case by case basis.

- 14. Failure to follow the general rules could result in an incomplete exhibit and may make a child a 4-H member ineligible to sell an animal in the auction.
- 15. The Fulton County 4-H Council, Inc. and Purdue Cooperative Extension Service accepts no responsibility for damages to or loss of 4-H projects while projects are in their care, custody, or control.
- 16. **Transportation of non-animal 4-H projects to and from the Indiana State Fair may be provided by Purdue Extension 4-H staff or volunteers. Large or Fragile projects going to the State Fair will be the responsibility of the 4-H member and his/her family. A 4-H member has the right to transport his/her project(s) to and from the Indiana State Fair or to elect not to exhibit at the State Fair. If you choose not to exhibit a selected project at the Indiana State Fair, you must notify the Extension Office by July 25th.**
- 17. Before the 4-H Council implements a rule change, the committee(s) with responsibility for the project area(s) affected by the rule must be notified and consulted before any change is made.
- 18. 4-H Project levels equal the following grade levels:

Division 1—3 rd Grade	Division 6—8 th Grade
Division 2—4 th Grade	Division 7—9 th Grade
Division 3—5 th Grade	Division 8—10 th Grade
Division 4—6 th Grade	Division 9—11 th Grade
Division 5—7 th Grade	Division 10—12 th Grade

Projects with 3 Levels
Level 1 or A—Grades 3-5
Level 2 or B—Grades 6-8
Level 3 or C—Grades 9-12

Junior/Beginner—Grades 3-8
Senior/Advanced—Grades 9-12

Projects with 4 Levels
Level 1 or A—Grades 3 & 4
Level 2 or B—Grades 5 & 6
Level 3 or C—Grades 7-9
Level 4 or D—Grades 10-12

Beginner—Grades 3-5
Intermediate—Grades 6-8
Advanced—Grades 9-12

*****Please note your grade level is determined by your grade as of JANUARY 1st of the current year*****

4-H COUNCIL ORGANIZATION INFORMATION

I. ORGANIZATION OF 4-H COUNCIL OF FULTON COUNTY, INC. (Revised December 2021)

1. It is the duty of the County Extension Educators to cooperate with the local community in organizing a 4-H club in each community in the county.
2. This reorganization is to be completed at the fall meeting. The Extension Office is to be notified of the member's names by November 15. Horse and Pony Advisory committee elects 4 members every year.
3. The voting membership of the 4-H COUNCIL OF FULTON COUNTY, INC. shall consist of one (1) representative from each 4-H Club, three (3) Junior Leaders, with the 3 going together for one (1) vote, one (1) 4-H Fair Association Representative, the 4-H Department Heads, Sale Committee Chairperson and Treasurer, four (4) persons who are "Friends of 4-H", further listed as At Large . It be further required that prior to every annual meeting, the 3rd Tuesday in October, the names of the persons qualifying for such membership for the coming year shall be furnished to the 4-H Council Executive Committee, which consists of President, Vice President, Secretary, and Treasurer, at least one (1) week prior to each annual meeting of the 4-H Council of Fulton County, Inc, the persons so selected to qualify as members under the aforesaid member qualifications shall be furnished to the Executive Committee of said Corporation except for the said four (4) At Large members to be appointed annually by the Executive Committee immediately following each annual meeting. Newly elected council members' terms will run from October 1 to September 30.
4. 4-H club leaders, project leaders, department chairmen, extension staff, project committees, and others may be involved in the implementation of 4-H policy, however, the 4-H Council of Fulton County, Inc. reserves the exclusive right to make and interpret 4-H policy and rules. In cases where a policy or rule interpretation must be made before a full council meeting, it can be held (such as during the fair) with the Executive Committee, as set out in 4-H Council by-laws, will act on behalf of the council and the decisions made by this group will be reported at the next council meeting.
5. All policy changes must be adopted no later than the November Council meeting, if they are to be implemented for that project year.
6. The 4-H Council of Fulton County, Inc. will establish 4-H policy for Fulton County.
7. All meetings of the 4-H Council of Fulton County, Inc. will be open to 4-H members, 4-H leaders, businesses, schools, other youth groups, and any other interested individuals.
8. The chairman of the 4-H Council of Fulton County, Inc. shall appoint such committees as may be needed to further implement the council's goals and purposes; such committees being: awards, rules and policy; finance; 4-H Fair and others as may be necessary.
9. The Council will also set up a 4-H and Youth Expansion Committee to study the total county program and youth needs and to recommend those programs needed to expand the 4-H and Youth Program. The 4-H Council of Fulton County, Inc. encourages and welcomes any member regardless of race, religion, color, sex, age, national origin, or ancestry, marital status, parental status, sexual orientation, disability or status as a veteran. Minority groups have and will continue to serve on the 4-H Council of Fulton County, Inc.

II. LOCAL 4-H CLUBS

1. Each local 4-H club must be supervised by at least one adult 4-H leader selected and approved by the local 4-H sponsoring committee in the community.
2. Each local club should hold a minimum of six scheduled 4-H meetings from October 1—June 30 each year.
3. A scheduled meeting will be those meetings that are planned at the beginning of the year and listed in the printed program.
4. Each scheduled local meeting shall consist of at least a business session and an educational feature.
5. **Each local 4-H leader shall prepare and submit a printed 4-H program to the County Extension Office on or before January 1st. Each program should show:**
 - a. **6 scheduled meetings**
 - b. **Time and place of meetings**

6. Guidelines for Fulton County 4-H clubs:
 - a. Have at least 1 or more approved adult leader in charge
 - b. Have project and Jr. Leader assistants as can be developed
 - c. Have at least 5 members
 - d. Have a club organization with necessary officers and a constitution and by-laws
 - e. Have a well-planned 4-H program developed by the program committee and adopted by the club
 - f. Strive to have at least one demonstration per member
 - g. It is suggested to hold 6-10 regular 4-H club meetings during the year
 - h. Strive to have at least 85 percent or more of the members complete one or more projects

III. Membership in Fulton County 4-H Clubs is open to all persons regardless of race, religion, color, sex, age, national origin, or ancestry, marital status, parental status, sexual orientation, disability or status as a veteran. Minority groups have and will continue to serve on the 4-H Council of Fulton County, Inc.

IV. **FINANCE**

1. The 4-H Council of Fulton County, Inc. will handle all financial matters pertaining to the Fulton County 4-H programs
2. A complete financial 4-H record will be kept by the treasurer of the 4-H Council of Fulton County, Inc. These records shall be open for public inspection at any time and will be audited at the start of each council year.
3. The 4-H Council of Fulton County, Inc. will prepare a county 4-H budget early in the 4-H year.

V. **4-H LIVESTOCK SALE**

1. The 4-H Council of Fulton County, Inc. will be responsible for the organization and conduct the 4-H Livestock Sale held at the county fair. The treasurer of the 4-H Livestock Sale Committee will furnish a financial report to the council by November 1 of each year.

VI. **ENROLLMENT**

1. 4-H project enrollment should be done online between October 1 and January 15. Payment must be received at the time of enrollment for the member to be considered enrolled.
2. All 4-H enrollments must be signed by a parent (guardian) before being accepted by the County Extension Office.
3. A 4-H member must be in 3rd through 12th grades as of January 1st to be eligible to enroll in 4-H.
4. For project manuals that have a charge, the manuals shall be purchased by the 4-H member and be his/her responsibility.
5. A boy or girl living in a county may be a 4-H member and an exhibitor in only one county during any given year unless a project is not offered in their home county.
6. 4-H Horse and Pony, Modeling Railroad, Fulton County Bullseyes, Dogs and Electric will be county-wide special interest clubs. Members enrolling in these clubs need not enroll in local or township clubs.

VII. **COMPLETION REQUIREMENTS**

1. **A 4-H Record of Achievement form** (with points on the back) should be filled out completely for the current year only and **turned in to the Fulton County Extension Office by the last Saturday of the fair. Record Sheets for each project will be checked when the project is entered for judging. ***FAILURE TO DO SO WILL RESULT IN 4-HERS FORFEITING ANY AND ALL COMPLETION, and PROMISE incentives for that year. Anyone earning State Fair points will be responsible for coming into the Extension Office and telling the Extension Educator by September 1.)**
2. 4-H members are encouraged to make public exhibits of the member's 4-H project work as announced by the County Extension Office (at the County 4-H judging and fair.).
3. Members are encouraged to have attended a minimum of four regularly scheduled local 4-H club meetings prior to time of making a project exhibit at the County 4-H judging and fair.
4. If a member is attending a 4-H training meeting or any county bona fide 4-H meeting or scheduled activity on a county or higher level, they are to be counted present at local club meetings.

VIII. JUDGING POLICIES

1. 4-H ribbons will be given to projects as follows:
 - a. Each project will be judged on the Danish System with Blue (A), Red (B), and White (C) ribbons.
 - b. In livestock judging, use of ribbons shall rest with the superintendents(s).
 - c. In any class an “A” ribbon will be given only if the exhibit is deemed deserving; otherwise, it will be placed as “B” or “C”.
 - d. Grand Champion and Champion will be given in all projects when an exhibit is deemed deserving of said ribbon by the judge regardless of the number of entries.
 - e. Reserve Grand Champion and Reserve Champion ribbons do not have to be awarded if the judge deems the entries are not deserving of said ribbons.
 - f. Those exhibits that do not follow requirements specified in the manual or fair exhibit requirements sent out by the Extension Office will be lowered one ribbon placing.
 - g. Those exhibits that do not follow requirements specified in the manual or fair exhibit requirements sent out by the Extension Office will be lowered one ribbon placing.
2. The awarding of Grand Champion indicates the best exhibit in the project. The Grand Champion and Reserve Grand Champion are chosen from the level Champions or best A ribbon projects if level Champions are not awarded.
3. The judges, using Indiana State Fair project entry guidelines, shall select state fair entries.
4. An exhibit (excluding livestock) shall not be entered in more than one (1) project.
5. An exhibit (excluding livestock) shall be prepared in the current 4-H year and shall only be exhibited during that year.
6. The placing of 4-H exhibits will not be adjusted after placings have become official.
7. Exhibitor’s project record sheet shall NOT be used as criteria during judging.
8. All Fair Judging—Judges’ decisions will be final.

FULTON COUNTY COLLEGE SAVINGS INCENTIVES

A NOTE FROM THE 4-H COUNCIL:



In cooperation with PROMISE FULTON COUNTY, the 4-H Council has established this program to provide financial incentives for project completion and involvement. The chart below explains the incentives which are attainable each year, based upon grade level.

The 4-H program has always strived to provide our members opportunities to be college and career ready after high school. In that spirit, these incentives will be in the form of contributions to a **529 COLLEGE CHOICE DIRECT SAVINGS ACCOUNT**. These tax advantageous accounts are a great tool for families to save for any post high school program—including trade schools, community college, 2- and 4- year traditional colleges.

FULTON COUNTY PROMISE has assisted Fulton County families opening 529 accounts for over 550 students since 2016.

We know the mere existence of an account regardless of the balance, increases by 3 times the chances of a child **ENROLLING** in a post high school course of study. It also increases by 4 times the chances of the child **COMPLETING** the course of study. Think of this program as a 4-H scholarship which could add up to nearly \$500 during a member's 4-H career.

Grade	Requirements	\$
3-6	BRONZE <ul style="list-style-type: none"> ▪ 4-H member must attend 2 club meetings through 4-H program year ▪ Must complete all projects enrolled in as of May 15th 	\$15
3-6	SILVER <ul style="list-style-type: none"> ▪ 4-H member must attend 2 club meetings through 4-H program year ▪ Must complete all projects enrolled in as of May 15th ▪ Volunteer during Fairgrounds Clean-up 	\$25
3-6	GOLD <ul style="list-style-type: none"> ▪ 4-H member must attend 2 club meetings through 4-H program year ▪ Must complete all projects enrolled in as May 15th ▪ Volunteer during Fairgrounds clean-up ▪ Attend a county, area, or state level camp or workshop (4-H Camp, Spark Club, Electric Workshop, Dog Workshop, YQCA, H & P clinics, Other advertised county workshops) 	\$40
7-12	BRONZE <ul style="list-style-type: none"> ▪ 4-H member must attend 2 club meetings through 4-H program year ▪ Must complete all projects enrolled in as of May 15th 	\$20
7-12	SILVER <ul style="list-style-type: none"> ▪ 4-H member must attend 2 club meetings through 4-H program year ▪ Must complete all projects enrolled in as of May 15th ▪ Volunteer during Fairgrounds Clean-up 	\$40
7-12	GOLD <ul style="list-style-type: none"> ▪ 4-H member must attend 2 club meetings through 4-H program year ▪ Must complete all projects enrolled in as May 15th ▪ Volunteer during Fairgrounds clean-up ▪ Attend a county, area, or state level camp or workshop (4-H Camp, Spark Club, Electric Workshop, Dog Workshop, YQCA, H & P clinics, Other advertised county workshops) 	\$50

FULTON COUNTY COLLEGE SAVINGS INCENTIVES

Completion Incentive. These are based upon the 4-H program year of **October 1-August 31**. **The completion incentive will be distributed into the 520 account by November 30, following the most recently completed 4-H year.** These awards are not cumulative. A member may qualify for a single level, based upon their level of involvement (grade level). Incentives will be based upon tracking by the Club leaders and Fairground Clean-up Supervisors.



Step by Step Guide for Families:

- ✓ Open each 4-H member a 529 college savings account (it only needs to be done once—amounts will be added to this one account each year) at:
www.collegechoicedirect.com/home/ymca/promise.html
- ✓ It only takes approximately 10 minutes to open the account online. You will need to have available:
 - Account owner's birthday and social security number (owner is typically a parent or guardian).
 - Account beneficiary's birthdate and social security number (beneficiary is the 4-H member). If you cannot find the SSN of the beneficiary, please contact Betty Martens at 475-835-9484. More than one beneficiary can be added under the same account.
 - You can start an account **with \$10 or more**. However, if this is not possible, at the time, please **click "Pay by Check."** **The Fulton County Promise funds will start the account with a \$25 Incentive Deposit. All accounts started qualify for this Incentive Deposit.**
- ✓ Review the list of Completion Incentives with your member and help them set a goal for which level they wish to achieve. Get to work on those 4-H projects and take full advantage of all the program has to offer!
- ✓ Watch your college savings grow! Those who earn a completion incentive will automatically see that money deposited into their 529 College Savings Account by the end of November.
- ✓ Have questions or need assistance? Contact:

Betty Martens at 574-835-9484 or
betty.m.promisefultoncounty@gmail.com

Fulton County



Mini 4-H





Mini 4-H is:

A learn-by-doing activity designed for Kindergarten, First, and Second Grade boys and girls who live in or go to school in the Fulton County area.

Mini 4-H is designed as a preparation activity for the 4-H program. Mini 4-H members are not required to attend meetings but may if they want to. There are no dues or cost for manuals. (There could be a cost involved for Electric and Micro Mini Tractor Pull). Members work with their parents to prepare their projects for exhibit at the Fulton County 4-H Fair.

We suggest that you choose projects that interest you to exhibit at the Fulton County 4-H Fair. For each project you exhibit, you will receive a special Mini 4-H ribbon.

Mini 4-H members will have the opportunity to come to events that are planned with them in mind such as Mini 4-H Craft nights and Mini 4-H Camp.



What to Do to Join Mini 4-H:

1. Look at the list of projects and decide what you would like to bring to the Fulton County 4-H Fair.
2. You may enroll online from October 1 through January 15 at <http://v2.4honline.com> or pick up an **enrollment form and return to: Fulton County Extension Service; 1009 W. Third Street; Rochester, IN 46975**. If you have questions, please call us at: **574-223-3397**.
3. You will receive your project materials through the mail, at a club meeting, or you may pick them up at the Extension Office.
4. There is no cost for the Mini 4-H manuals or to join Mini 4-H. If you join a 4-H club, you may be asked to pay club dues.
5. Mini 4-H members in Kindergarten, First, and Second Grades will be allowed to show, work with, or care for animal projects after their legal guardian has signed a liability release. Mini 4-H members may independently show, work with, or care for animals that weigh 300 pounds or less. Mini 4-H members may only show, work with, or care for animals over 300 pounds when they are assisted by a parent, guardian, or another adult designated in writing by the parent or legal guardian (*Assisted means with the child at all times*).
6. Indiana Mini 4-H members may not handle firearms—Purdue’s liability coverage does NOT extend to that age group.
7. Mini 4-H members exhibiting horses must wear ASTM or SEI standard F1163 (or above) certified helmets whenever mounted.
8. Mini 4-H member are covered by insurance.





Mini 4-H Project List

Arts & Crafts—Exhibit an art or craft that you have made. The exhibit could be fine arts pictures done with paint, crayons, etc.; needlecrafts that are done with a needle; basic crafts done with wood, plaster, ceramics, etc.; stuffed animal pillows, beads, weaving, etc.

Beef—Care for a beef calf born between Feb. 15 and April 30. Participate in the Beef Show during the fair. If the animal is over 250 pounds the parent/guardian must have control of the animal.

Cat—Learn about and care for your cat. Participate in the Cat Show during the fair.

Collections—Exhibit a part of your favorite collections. Ideas include matchbox cars, coins, pencils, shells, super hero figures, etc.

Dairy Calf—Care for a dairy calf born between February 15 and April 30. Your dairy calf can be a heifer, steer, or bull calf. Participate in the Dairy Show during the fair.

Do Your Own Thing—Make an object or poster covering any topic of your choice.

Electric—Learn about electricity and safety. For this project, they will go to the REMC for meetings and to pick up their little projects. **THERE MAY BE A SMALL COST FOR THIS PROJECT.**

Farm Animals—Learn about farm animals by coloring pictures and displaying a poster.

Farm Toy Scene—Exhibit a farm or construction scene.

Foods—Learn how to make no-bake cookies or simple treats.

Goats—Care for a goat. Your goat can be any age and either male or female. Participate in the Goat Show during the fair.

Horse & Pony—Care for a horse or pony. Participate in the Fun Show during the fair.

Micro-Mini Tractor Pull—Youth build from scratch, a 1/16 scale pulling tractor (farm). Project guidelines and information is available at Micro Mini workshops. **THERE MAY BE A COST FOR BUYING THE TRACTOR.**

Models & Legos—Put together a simple model or Lego project.

Photography—3 pictures mounted on a poster.

Plants & Flowers—Care for a flower, vegetable, or houseplant.

Poultry—Care for a chicken or a duck. Participate in the Poultry Show during the fair.

Rabbit—Care for a rabbit. Your rabbit can be any age and any breed. Participate in the Rabbit Show during the fair.

Scarecrow—Make a scarecrow with your family.

Sheep—Care for a lamb. Your lamb can be a market lamb or a ewe. The lamb can be enrolled in 4-H by a member of your family. Participate in the Sheep Show during the fair.

Swine—Care for a pig, either a barrow or gilt. The pig must be already enrolled in 4-H by a 4-H member. Participate in the Swine Show during the fair.

Wildlife—Learn about wild animals by coloring animals and making a poster to display.

4-H Community Building (Non-Walking)

Project Exhibit Guidelines



FULTON COUNTY 4-H COMMUNITY BUILDING GENERAL EXHIBIT GUIDELINES

1. 4-H project manuals and guidelines are designed to coordinate with a member's grade level in school. If you are entering 4-H for the first time or rejoining or if you are enrolling in a new community building project for the first time, you must enroll in the division that corresponds with your current grade level as of January 1 unless specified differently for that project. Exceptions to this clause may be presented by written note (signed by the 4-H member) to the Extension Educator.
2. **All poster exhibits are to be 22" x 28". It is suggested they be mounted on a firm backing and covered in clear plastic or other transparent material and must be displayed horizontally. Matte board is acceptable as poster board but needs additional stiff backing.**
3. **Displays are to be no larger than 2'x 3'x 3' (outside dimensions) unless specified differently in project manual.**
4. **All posters, notebooks and display boards must include a reference list indicating where information was obtained, giving credit to the original author, to complete the 4-H member's exhibit. This reference list should/might include website links, people and professionals interviewed, books, magazines, etc. It is recommended this reference list be attached to the back of a poster or display board, be the last page of a notebook, or included as part of the display visible to the public. A judge is not to discredit an exhibit for the manner in which references are listed.**
5. The 4-H exhibit tag must be placed in the lower right-hand corner of the poster. The tag is 5½ inches tall and 3 inches wide.
6. All exhibits that may become soiled should be covered with clear plastic; especially Sewing, some Arts and Crafts exhibits, and Home Environment items, etc.
7. No exhibits may be changed by anyone without prior approval of the 4-H educator (either changing to a different category or altering of the exhibit itself) following the judging or entry of the item.
8. No boy or girl can exhibit more than one division in non-livestock 4-H projects.
9. Attendance of 4-H members is not required at project judging but it is strongly encouraged.
10. The Community Building Committee will consider dropping projects with less than 3 in project for 3 years.

Community Building Exhibit Displays are to be no larger than 2'x3'x3' (outside dimensions) unless specified differently in the project manual. If your project is larger than this size or very valuable, you may bring it to Project judging along with a poster or notebook describing how and what you made. The notebook or poster will be on display during fair week and be considered your exhibit.

Rules During 4-H Events

- ❁ **Overnight Stay at Fairgrounds**—4-H members are not allowed to stay overnight at the fairgrounds unless accompanied by his/her parent or legal guardian. The time associated with overnight is that time when the fair shuts down for the evening or by midnight until early morning feeding of animals (early morning is normally construed as morning light in our summer season.)
- ❁ **Dogs**—Dogs are not allowed on the Fulton County 4-H Fairgrounds during County Fair week. Exceptions: Service Dogs (Seeing Eye dogs, etc.) and dogs enrolled in the 4-H Dog Obedience project on Show Day.
- ❁ **Parking During Fair Week**—There is no parking allowed on the east side of Third Street after 4:00 p.m. (The area inside the fence around the barns and buildings.) Parking is allowed in the parking lot on the west side of Third Street.
- ❁ **Alcohol**—There will be no alcohol on the grounds for any 4-H event.

POSTER UPDATES

It is suggested that all poster exhibits be mounted on a background board 22 inches by 28 inches, displayed horizontally, mounted on **stiff backing (foam board, corrugated board, thin paneling, or thin luan board—keep it thin and light)** and covered with clear acetate/plastic. Matte board is acceptable as poster board but **needs additional stiff backing.**

All posters, notebooks and display boards must include a reference list indicating where information was obtained, giving credit to the original author, to complete the 4-H member's exhibit. This reference list should/might include website links, people and professionals interviewed, books, magazines, etc. It is recommended that this reference list be attached to the back of a poster or display board, be the last page of a notebook, or included as part of the display visible to the public.

Posters are to be 22"x28" and displayed horizontally and placed in a clear plastic sleeve or covered with clear plastic to protect contents. Display boards should be designed to sit on a table using no more than 36" of tabletop space. Space should be left in the lower right-hand corner to place an exhibit tag provided by Purdue Extension staff.

Judges evaluating exhibits should recognize individual differences and creativity, therefore using information in this document as a guide rather than a requirement.

Poster Exhibit Guidelines

1. **Poster Board**—Use white when required by your county and experiment with other colors when not required. All posters must be 22" x 28" unless otherwise specified.
2. **Mounting Adhesives**—rubber cement works best as it leaves no marks and will not wrinkle paper. White glue should be used only in cases when wrinkling or damage will not occur.
3. **Colored Pencils**—The best pencils are soft leaded since they are easy to use and blend well and strokes will not show if handled properly. Hard leaded pencils are less expensive but are more difficult to use. Soft leaded pencils can be purchased at art stores.)
4. **4-H Exhibit Tags**—Labels for posters will be supplied by the 4-H office to identify 4-H member, project, and level. This label will be attached **to the lower right-hand corner of the poster**. Please adjust your display accordingly. The tag will be **5½ inches tall and 3 inches wide**.
5. **Stiff backing**—Any material that will keep the poster from bending forward will work. Some examples are: foam core board, very stiff cardboard, plywood (this can make a poster very heavy); and Masonite (1/8" thick is found to work well and could be used year after year.) If you can find foam core board in the correct size it can take the place of poster and backing.
6. **Acetate or other clear plastic covering**—Required for most poster projects. It keeps them clean and keeps fairgoers from touching the poster. Clear heavy plastic sleeves are available from the Extension Office for \$1.00 each. Do not use kitchen wrap.
7. **Plastic or cloth tape**—Tape is not necessary but it makes attaching poster board to the stiff backing easy. Tape is available in many colors and widths. The 1½" wide tape can give the poster a border and is available at discount stores.
8. **Lettering**—Stencils, self-adhesive, or press-type letters may be purchased at discount or art stores. Some youth prefer to print their labels and title from a computer.
9. **Your poster should be oriented horizontally, like a dollar bill (see below).**

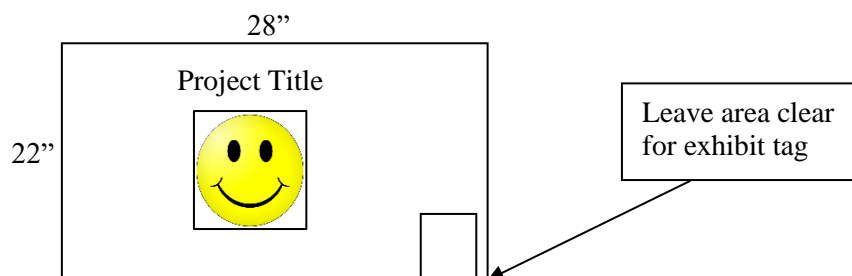

4-H ACHIEVEMENT RECORD BOOK



No State Fair Exhibits

Grades 3, 4 & 5

Grades 6, 7, 8, 9, 10, 11, & 12

Manual:

- Fulton County My 4-H Achievement Record Book Project Manual

The Achievement Record Book is to assist you as a 4-H member with recordkeeping and will help with resumé writing in later years. Also, it provides a detailed scrapbook of your 4-H Career. This form is designed so that you record all information now and important items can be selected later when working on Accomplishment Resumés. When assembling your Achievement Record Book, include all years up to and including the present year. If you are beginning your Achievement Record Book after you have been in 4-H for several years, you may need to “lump” some years together—do the best you can!

Divisions 1, 2, & 3 (Grades 3-5)

Project Completion: Turn in completed record sheet to finish the project.

Exhibit: One or more Notebooks containing your 4-H Story (2-3 pages double-spaced) and pictures. See manual for more information. On “Your Story”, use no smaller than a size 12 font; a size 14 font is preferred.

- Cover
- Individual photo
- Information sheet
- Experiences in 4-H
- 4-H Leadership Experiences
- Citizenships/Community Service

Divisions 4 through 10 (Grades 6-12)

Project Completion: Turn in completed record sheet to finish the project.

Exhibit: One or more Notebooks containing your 4-H Story (up to 5 pages double-spaced) and pictures. See manual for more information. On your story, use no smaller than a size 12 font; a size 14 font is preferred.

- Cover
- Individual photo
- Information sheet
- Experiences in 4-H
- 4-H Leadership Experiences
- Citizenship/Community Service

AEROSPACE

State Fair Project

One rocket, remote control aircraft, or drone may be exhibited at the State Fair.
6 State Fair Exhibits (3 rockets, drones, remote control aircraft, posters, notebooks or display boards per county; one per level.)

Beginner—Grades 3, 4, & 5

Manual: Aerospace 2: Lift-Off

Intermediate—Grades 6, 7, & 8

Manual: Aerospace 3: Reaching New Heights

Advanced—Grades 9, 10, 11, & 12

Manual: Aerospace 4: Pilot in Command

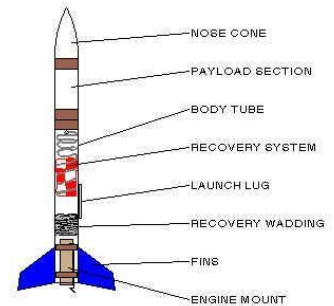

The 4-H aerospace program provides youth with educational information and experiences about aerodynamics, flight and rocketry. In Aerospace, you need to enroll in a Stage, based upon your grade level as of January 1st of the current year. Under each Stage, you then select a level according to your ability. You may choose the current grade level or if you are a first-time rocket builder you may select a lower grade level within the Stage. No “Ready to Fly” or E2X rockets are acceptable in the 4-H Aerospace project.

Exhibit Guidelines:

All posters, notebooks, and display boards must include a reference list indicating where information was obtained, giving credit to the original author, to complete the 4-H member’s exhibit. This reference list should/might include web site links, people and professionals interviewed, books, magazines, etc. It is recommended this reference list be attached to the back of a poster or display board, be the last page of a notebook, or included as part of the display visible to the public. A judge is not to discredit an exhibit for the way references are listed.

Posters are to be 22”x28” and displayed horizontally and placed in a clear plastic sleeve or covered with clear plastic to protect contents. Display boards should be designed to sit on a table using no more than 36” of tabletop space. Space should be left in the lower right-hand corner to place an exhibit tag provided by Purdue Extension staff.

Judges evaluating exhibits should recognize individual differences and creativity, therefore using information in this document as a guide rather than a requirement.

“Ready to Fly” and E2X rockets are not permitted. Rockets may be exhibited with a base, but launch pads are not permitted. All rockets must weigh less than 3.3 pounds and considered an amateur rocket according to FAA regulations. Remote control aircraft or drones may be constructed from a kit or purchased ready-to-fly. The power source (rocket engine, battery pack, etc.) is to be removed before being placed in public exhibition.

Rockets will not be launched and remote-control aircraft or drones will not be flown at state fair. Launching rockets and flying aircraft or drones at the county level is optional based on adult supervision experience.

Needed for judging:

- Aerospace Record Sheet
- Rockets may be exhibited with a base, but launch pads are not permitted. All rockets must weigh less than 3.3 pounds and considered an amateur rocket according to FAA regulations.
- Remote control aircraft or drones may be constructed from a kit or purchased ready to fly.

Beginner (grades 3-5 suggested):

Construct a rocket of your choice designed for a new model rocket enthusiast with a difficulty level that is appropriate for the suggested grade level, or a poster or display board on any topic in the manual. Similar topics not included in the manual are permissible. Rockets cannot be ready-to-fly (RTF) or have plastic fins. Cluster engine rockets and rockets that take an engine D or above are not permitted in this level.

Remote control aircraft or drone of your choice that is age/grade appropriate and compliant with FAA regulations, federal and state laws, and local ordinances. This exhibit choice is to include a notebook or poster including how the aircraft/drone was used and aerospace skills learned. Displaying the aircraft or drone is optional.

Intermediate (grades 6-8 suggested):

Construct a rocket of your choice designed for a model rocket enthusiast with some experience and with a difficulty level that is appropriate for the suggested grade level, or a poster or display board on any topic in the manual. Similar topics not included in the manual are permissible. Rockets cannot be ready-to-fly (RTF) or have plastic fins. Cluster engine rockets and rockets that take an engine E or above are not permitted in this level.

Remote control aircraft or drone of your choice that is age/grade appropriate and compliant with FAA regulations, federal and state laws, and local ordinances. This exhibit choice is to include a notebook or poster including how the aircraft/drone was used and aerospace skills learned. Displaying the aircraft or drone is optional.

Advanced (grades 9-12 suggested):

Construct a rocket of your choice designed for an experienced model rocket enthusiast and with a difficulty level that is appropriate for the suggested grade level, or a poster or display board on any topic in the manual. Similar topics not included in the manual are permissible. Rockets cannot be ready-to-fly (RTF) or have plastic fins. Cluster engine rockets and rockets that take an engine G or above are not permitted in this level.

Remote control aircraft or drone of your choice that is age/grade appropriate and compliant with FAA regulations, federal and state laws, and local ordinances. This exhibit choice is to include a notebook or poster including how the aircraft/drone was used and aerospace skills learned. Displaying the aircraft or drone is optional.

County Fair Judging and Launching Guidelines:

The rocket judging will be held on Saturday during project check-in. 4-H members are not required to be present during the rocket judging but it is recommended.

4-H members will have the opportunity to launch their rockets on Friday morning during fair week. If a 4-H member has a rocket selected for State Fair, they have the option of launching that rocket or a substitute one.

1. Rockets will be judged for proper construction.
2. All rockets will be checked for safety before they are launched.
3. Launching Rules:
 - a. No alternating from the basic rocket kit. (Scratch built rockets are acceptable.)
 - b. Launch pad angle should be no more than 30°.
 - c. Only 4-H members allowed in launch area.
 - d. Each member will be allowed to launch their rocket once.
 - e. Rockets will be launched by divisions with each member having their turn.



ARTS & CRAFTS SECTION

State Fair Eligible projects are listed first:

- **Arts and Crafts, General**—formerly known as “Other Crafts”. Holiday Decorations will now be included in this project and not be a separate project as in the past. (You **will not** be able to choose “Holiday Decorations” but in the **Arts & Crafts, General** project, you may do something holiday related.)—5 entries per county as determined by the county 4-H educator and fair officials.
- **Construction and Architectural Replica**—formerly known as “Farm Toy & Construction Toy Scene”—1 entry per county as determined by the county 4-H educator and fair officials.
- **Fine Arts**—2 entries per county as determined by the county 4-H educator and fair officials.
- **Model Crafts**—2 entries per county as determined by the county 4-H educator and fair officials.
- **Needle Crafts**—2 entries per county as determined by the county 4-H educator and fair officials.

Non-State Fair projects are listed after that and are classified as Arts & Crafts, General:

- Arts & Crafts, General: Gift Wrapping
- Arts & Crafts, General: Legos
- Arts & Crafts, General: Model Railroad
- Arts & Crafts, General: Recycling
- Arts & Crafts, General: Scarecrow

ARTS AND CRAFTS, GENERAL

(Formerly known as Other Crafts)

5 Exhibits allowed for the State Fair

This project allows youth to learn life skills and grow in project knowledge while expressing creativity in a variety of mediums.



These categories may go to the State Fair:

- ✿ Arts and Crafts, General—formerly known as “other crafts”. Holiday Decorations will now be included in this project and not be a separate project as in the past.
- ✿ Construction and Architectural Replica—formerly known as “Farm Toy & Construction Toy Scene”
- ✿ Fine Arts
- ✿ Model Crafts
- ✿ Needle Crafts

Exhibit Guidelines:

- Turn in completed record sheet to finish the project.
- Youth may exhibit any art or craft that does not meet exhibit requirements in Fine Arts, Needle Craft, Model Craft or Construction and Architectural Replica.
- Exhibitors should be considerate of space. Exhibits too large to safely move or requiring lots of space should be exhibited using photographs and a description of work in a notebook.
- All arts and craft exhibits must include a [4-H Craft Information Card, 4-H 618A](#). This information card is to describe work completed so the judge can more accurately evaluate the exhibit. Craft information cards are for judging purposes only and will not be returned to the exhibitor.
- If multiple pieces make up the exhibit, a photograph of the complete exhibit should be attached to the exhibit so the total exhibit can properly be displayed. For safety purposes any craft exhibit that resembles a sword, knife, or look-a-like weapon will be judged but will not be displayed.
- Judges evaluating exhibits should recognize individual differences and creativity, therefore using information in this document as a guide rather than a requirement.

Arts & Craft, General Ideas—Suggestions but not limited to:

Basket Making	Fabric Craft	Leather	Plaster Craft	Scrap
Bead	Felt	Machine Knitting	Plastic Canvas	Seed
Candle Making	Fused Glass	Machine Quilting	Pottery	Sew for Fun
Ceramics	Holiday Decor	Macramé	Quilting	Tie Dye
Clothing Embellishment	Jewelry	Metal	Reed Craft	Woodcraft
Decoupage	Latch Hook	Paint by Number		

Beginner (Grades 3-5 suggested)

Create and exhibit one age/grade appropriate artwork.

Intermediate (Grades 6-8 suggested)

Create and exhibit one age/grade appropriate artwork.

Advanced (Grades 9-12 suggested)

Create and exhibit one age/grade appropriate artwork

CONSTRUCTION AND ARCHITECTURAL REPLICA

(Formerly known as Farm Toy & Construction Toy Scene)

1 Exhibit allowed for State Fair

Allows youth to learn life skills and grow in project knowledge while expressing creativity when designing replicas.



These categories may go to the State Fair:

- ✿ Arts and Crafts, General—formerly known as “other crafts”. Holiday Decorations will now be included in this project and not be a separate project as in the past.
- ✿ Construction and Architectural Replica—formerly known as “Farm Toy & Construction Toy Scene”
- ✿ Fine Arts
- ✿ Model Crafts
- ✿ Needle Crafts

Exhibit Guidelines:

- Turn in completed record sheet to finish the project.
- Exhibits can include farm scenes, town models, building replicas, or similar items and can be constructed from any material as in the past years but can now include building blocks, Legos, erector sets, etc. The product should be constructed to scale as much as possible. Consider adding a clear cover to protect the exhibit while being displayed to the public. This exhibit will most likely be displayed on an 8’ long table top with two or three exhibits per table.
- Exhibitors should be considerate of space. Exhibits too large to safely move or requiring lots of space should be exhibited using photographs and a description of work in a notebook.
- All arts and craft exhibits must include a [4-H Craft Information Card, 4-H 618A](#). This information card is to describe work completed so the judge can more accurately evaluate the exhibit. Craft information cards are for judging purposes only and will not be returned to the exhibitor.
- If an exhibitor is concerned about their creation being damaged while on display, they should consider constructing a clear plastic cover to encase the exhibit.
- Judges evaluating exhibits should recognize individual differences and creativity, therefore using information in this document as a guide rather than a requirement.

Grades 3, 4, & 5

- Create and exhibit one age/grade appropriate artistic scene or replica.

Grades 6, 7, & 8

- Create and exhibit one age/grade appropriate artistic scene or replica.

Grades 9, 10, 11, & 12

- Create and exhibit one age/grade appropriate artistic scene or replica.





FINE ARTS

2 Exhibits allowed for the State Fair

Allows youth to learn life skills and grow in project knowledge while expressing creativity through painting and drawing.

These categories of Arts & Crafts may go to the State Fair:

- ✿ Arts and Crafts, General—this is the same as “other crafts” in the past. Holiday Decorations will now be included in this project and not be a separate project as in the past.
- ✿ Construction and Architectural Replica—this is the same as “Farm Toy & Construction Toy Scene” in the past.
- ✿ Fine Arts
- ✿ Model Crafts
- ✿ Needle Crafts

Exhibit Guidelines:

- Turn in completed record sheet to finish the project.
- All arts and craft exhibits must include a [4-H Craft Information Card, 4-H 618A](#). This information card is to describe work completed so the judge can more accurately evaluate the exhibit. Craft information cards are for judging purposes only and will not be returned to the exhibitor.
- Oil, charcoal, pastels, pencil, ink, acrylic, watercolor or similar artistic work can be displayed on canvas, canvas board, or paper.
- All work must be framed as a picture and prepared for hanging.
- Canvas art on a wooden frame is considered prepared for hanging provided that frame has a hanger.
- Judges evaluating exhibits should recognize individual differences and creativity, therefore using information in this document as a guide rather than a requirement.

Beginner (Grades 3-5 suggested)

Create and exhibit one age/grade appropriate artwork.

Intermediate (Grades 6-8 suggested)

Create and exhibit one age/grade appropriate artwork.

Advanced (Grades 9-12 suggested)

Create and exhibit one age/grade appropriate artwork.

MODEL CRAFTS

2 Exhibits allowed for State Fair

This project allows youth to learn life skills and grow in project knowledge while expressing creativity when building a model.



These categories may go to the State Fair:

- ✿ Arts and Crafts, General—this is the same as “other crafts” in the past. Holiday Decorations will now be included in this project and not be a separate project as in the past.
- ✿ Construction and Architectural Replica—this is the same as “Farm Toy & Construction Toy Scene” in the past.
- ✿ Fine Arts
- ✿ Model Crafts
- ✿ Needle Crafts

Exhibit Guidelines: Model Craft Exhibits must be a small-scale replica and meet the following criteria:

- Turn in completed record sheet to finish the project.
- All arts and craft exhibits must include a [4-H Craft Information Card, 4-H 618A](#). This information card is to describe work completed so the judge can more accurately evaluate the exhibit. Craft information cards are for judging purposes only and will not be returned to the exhibitor.
- If multiple pieces make up the exhibit, a photograph of the complete exhibit should be attached to the exhibit so the total exhibit can properly be displayed. For safety purposes any craft exhibit that resembles a sword, knife, or look-a-like weapon will be judged but will not be displayed.
- Exhibits must be a small-scale replica made of injected styrene plastics with approximately 25% of the surface painted. Wood, paper, clay die-cast, or snap together models are not permitted. Screws and pre-painted or pre-decaled factory models are not permitted. Exhibits made from building blocks (Lego) are not permitted.
- If the model is being built from a kit, include a copy of the instructions with the information card. Original instructions should be kept by the exhibitor in a safe location at home.
- Judges evaluating exhibits should recognize individual differences and creativity, therefore using information in this document as a guide rather than a requirement.

Beginner (Grades 3-5 suggested)

Create and exhibit one age/grade appropriate model.

Intermediate (Grades 6-8 suggested)

Create and exhibit one age/grade appropriate model.

Advanced (Grades 9-12 suggested)

Create and exhibit one age/grade appropriate model.

NEEDLE CRAFTS

2 Exhibits allowed for State Fair

This project allows youth to learn life skills and grow in project knowledge while expressing creativity in needle crafts.

These categories may go to the State Fair:

- ✿ Arts and Crafts, General—this is the same as “other crafts” in the past. **Holiday Decorations will now be included in this project and not be a separate project as in the past.**
- ✿ Construction and Architectural Replica—this is the same as “Farm Toy & Construction Toy Scene” in the past.
- ✿ Fine Arts
- ✿ Model Crafts
- ✿ Needle Crafts

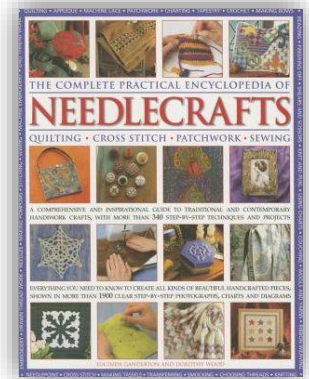

Exhibit Guidelines:

- Turn in completed record sheet to finish the project.
- All arts and craft exhibits must include a [4-H Craft Information Card, 4-H 618A](#). This information card is to describe work completed so the judge can more accurately evaluate the exhibit. Craft information cards are for judging purposes only and will not be returned to the exhibitor.
- Hand crafted knitting, embroidery, crocheting, needlepoint, crewel, candle wicking, chicken scratching, hand quilting, tatting, huck embroidery, and hemstitching are suggested exhibits. Entries may also include pulled, drawn and counted thread work and punch needle work.
- **Needle craft exhibits do not include latch hook, plastic canvas, machine knitting, machine quilting, or arm knitting/crocheting—These will fall under the Arts and Crafts, General category.**
- Judges evaluating exhibits should recognize individual differences and creativity, therefore using information in this document as a guide rather than a requirement.

Beginner (Grades 3-5 suggested)

Create and exhibit one age/grade appropriate needle craft.

Intermediate (Grades 6-8 suggested)

Create and exhibit one age/grade appropriate needle craft.

Advanced (Grades 9-12 suggested)

Create and exhibit one age/grade appropriate needle craft.

Examples of Needle Craft include:

Counted Cross Stitch

- **Counted Cross Stitch:** Any needlework done on material as a counted thread (cross stitch) technique.
 - Suggested Articles: jar lid cover, small simple picture, bread basket towel, finger towel, sampler, pillow top

Embroidery, Crewel, Chicken Scratch OR Candlewicking

- **Embroidery:** A type of needlework where a needle and thread are used to decorate a piece of fabric
- **Crewel:** Needlework similar to embroidery where yarn is used to decorate fabric
- **Chicken Scratch:** A typed of embroidery done on gingham fabric
- **Candlewicking:** A form of whitework embroidery that traditionally uses an unbleached cotton thread on a piece of unbleached muslin. It gets its name from the soft spun cotton thread which was braided and used to form the wick for candles.
 - Suggested Articles: pillowcase, tea towel, pot holder, baby bib, or picture.



Other Needlework

- **Needlepoint:** Any needlework done on canvas
- **Hand Appliqué, Hand Quilting, Tatting, Lace making, etc.** (All projects in this category must be done by hand. Anything done by machine would be in OTHER CRAFTS.)
- **Punch Needlework:** Any article using a punch needle, (i.e.) pillows, pictures, wall hanging, table mats, etc.
- **Quilting:** Any article that has three (3) layers sandwiched as one, except for novelty quilts such as yo-yo and cathedral window. This means that a top is either pieced, embroidered, appliquéd, or solid laid on top of a backing material with a batting laid between and then sewn together and sewn by hand or knotted with yarn. All work must be done by the 4-Her—pieced and quilted by the 4-H member.
 - Suggested Articles: bag, wall hanging, placemat, etc.
- **Tatting:** Any lace made with a tatting shuttle.
- **Weaving:** Weaving done on a loom or off loom weaving.
 - Suggested Articles: purse, belt pillows wall hanging, table mats, etc.
- **Crochet:** Any crocheted article or set using crochet hook and thread or yarn. Possible Resources: ABC of Crocheting: Left- or Right-Hand version.
 - Suggested Articles: slippers, pot holders, placemat, hat, vest, mittens afghan, sweater, etc.
- **Knitting:** Any knitted article or set using knitting needles and thread or yarn.
 - Suggested Articles: slippers, pot holders, placemats hat, vest, mittens, afghan, sweater, etc.



ARTS AND CRAFTS, GENERAL: GIFT WRAPPING

No State Fair Exhibit *County Project*

Division 1	Division 6	8 th Grade
Division 2	Division 7	9 th Grade
Division 3	Division 8	10 th Grade
Division 4	Division 9	11 th Grade
Division 5	Division 10	12 th Grade
7 th Grade		



Manual:

- Fulton County Gift Wrapping Manual
- Pinterest and YouTube are also good sources to check for ideas.

General Guidelines—All Divisions:

1. **Do Not** put a gift in the wrapped package unless it is part of the irregular-shaped box requirement for Division 8.
2. Each wrapped package should include an index card containing the following information. It should be attached to the bottom of your package:
 - a. Occasion for the gift
 - b. Gender of the recipient
 - c. Age of the recipient
3. Attach your printed exhibit card (provided for you from the office) to the ribbon on your package. This way it can be moved freely by the judge. Judging will be based on neatness, originality, creativity, and appropriateness of materials chosen.
4. Turn in completed Gift Wrapping Record Sheet.

Division 1—Grade 3—Small Gift Box

Project Completion: Turn in completed record sheet to finish the project.

Exhibit: One small gift box with a purchased bow

- Attach the index card to the bottom and the exhibit card to your package by a ribbon.
- Judging will be based on neatness only.

Division 2—Grade 4—Large Rectangular Shirt Box

Project Completion: Turn in completed record sheet to finish the project.

Exhibit: One large shirt box and attach a self-made bow with loops.

- Attach the index card to the bottom and the exhibit card to your package by a ribbon.
- Judging will be based on neatness, originality, creativity and appropriateness of materials chosen.

Division 3—Grade 5—Kleenex or Tissue Box

Project Completion: Turn in completed record sheet to finish the project.

Exhibit: One wrapped Kleenex or tissue box—rectangular or square. A self-made bow with loops is to be attached to the package.

- Attach the index card to the bottom and the exhibit card to your package by a ribbon.
- Judging will be based on neatness, originality, creativity and appropriateness of materials chosen.

Division 4—Grade 6—Shoe Box

Project Completion: Turn in completed record sheet to finish the project.

Exhibit: One wrapped shoe box. A self-made bow with loops is to be attached to the package.

- Attach the index card to the bottom and the exhibit card to your package by a ribbon.
- Judging will be based on neatness, originality, creativity and appropriateness of materials chosen.

Division 5—Grade 7—Jewelry Box

Project Completion: Turn in completed record sheet to finish the project.

Exhibit: One wrapped jewelry box. A self-made bow with loops is to be attached to the package.

- Attach the index card to the bottom and the exhibit card to your package by a ribbon.
- Judging will be based on neatness, originality, creativity and appropriateness of materials chosen.

Division 6—Grade 8—Shoe Box

Project Completion: Turn in completed record sheet to finish the project.

Exhibit: One wrapped shoe box with top and bottom wrapped separately. The box must have tissue paper inside. Attach your own bow with loops and trimmings.

- Attach the index card to the bottom and the exhibit card to your package by a ribbon.
- Judging will be based on neatness, originality, creativity and appropriateness of materials chosen.

Division 7—Grade 9—Cylinder-Shaped Box

Project Completion: Turn in completed record sheet to finish the project.

Exhibit: Wrap a cylinder-shaped box. Attach your own bows and trimmings.

- Attach the index card to the bottom and the exhibit card to your package by a ribbon.
- Judging will be based on neatness, originality, creativity and appropriateness of materials chosen.

Division 8—Grade 10—Irregular-Shaped Box

Project Completion: Turn in completed record sheet to finish the project.

Exhibit: One wrapped irregular-shaped box such as a heart, star, hexagonal, or odd-shaped toy box, etc. Attach your own bows and trimmings.

- Attach the index card to the bottom and the exhibit card to your package by a ribbon.
- Judging will be based on neatness, originality, creativity and appropriateness of materials chosen.

Division 9—Grade 11—Series of up to 3 Boxes

Project Completion: Turn in completed record sheet to finish the project.

Exhibit: Individually wrap a series (of not more than three) boxes in tiers. Attach your own bows and trimmings.

- Attach the index card to the bottom and the exhibit card to your package by a ribbon.
- Judging will be based on neatness, originality, creativity and appropriateness of materials chosen.

Division 10—Grade 12—Series of up to 3 Boxes

Project Completion: Turn in completed record sheet to finish the project.

Exhibit: Individually wrap a series (of not more than three) boxes in tiers. Use something other than gift wrapping paper. Attach your own bows and trimmings.

- Attach the index card to the bottom and the exhibit card to your package by a ribbon.
- Judging will be based on neatness, originality, creativity and appropriateness of materials chosen.



ARTS AND CRAFTS, GENERAL: LEGOS



No State Fair Exhibits *County Project* No Manual

The Legos project allows 4-H members to create projects with Legos, K-Nex, Construx, Erector, Tinker Toys, Lincoln Logs, and Duplo Blocks. There are lots of different things you can do with this project. Remember, the exhibit must be transported and moved for judging and fair display. You may want to consider how well your project holds/stays together. Since there are not a lot of guidelines with this project—be creative!

Since you have the option of a poster, here are some guidelines:

All posters, notebooks and display boards must include a reference list indicating where information was obtained, giving credit to the original author, to complete the 4-H member's exhibit. This reference list should/might include website links, people and professionals interviewed, books, magazines, etc. It is recommended that this reference list be attached to the back of a poster or display board, be the last page of a notebook, or included as part of the display visible to the public.

Posters are to be 22"x28" and displayed horizontally and placed in a clear plastic sleeve or covered with clear plastic to protect contents. Display boards should be designed to sit on a table using no more than 36" of tabletop space. Space should be left in the lower right-hand corner to place an exhibit tag provided by Purdue Extension staff.

Judges evaluating exhibits should recognize individual differences and creativity, therefore using information in this document as a guide rather than a requirement.

Grades 3, 4, & 5

Project Completion: Turn in a completed record sheet to finish the project

Exhibit: Kits are recommended. Construct a character such as an animal, a person, or a statue (figurine). Exhibit **SHOULD NOT** be a building or scene of any kind—just one (1) item.

- Exhibit an animal, person, or statue (figurine).
- Exhibit must be no taller than 24 inches high.
- Exhibit must rest on a sturdy base which is no more than 24 inches square. It can be smaller.
- Blocks may be glued together, but it's not mandatory.
- Members should construct a more advanced project each year.
- Members have the option of constructing a poster displaying their architectural model, along with related information, in place of displaying the actual model.



Grades 6, 7, & 8

Project Completion: Turn in completed record sheet to finish the project.

Exhibit: Kits may be used. Construct a structure, a scene or some form of transportation (car, plane, etc.)

- Exhibit should be a structure, a scene, or a form of transportation.
- Exhibit must be no taller than 24 inches high.
- Exhibit must rest on a sturdy base which is no more than 24 inches square. It can be smaller.
- Blocks may be glued together, but it's not mandatory.
- Members should construct a more advanced project each year.
- Members have the option of constructing a poster displaying their architectural model, along with related information, in place of displaying the actual model.



Grades 9, 10, 11, & 12

Project Completion: Turn in completed record sheet to finish the project.

Exhibit: Kits may be used. Must use moveable or motorized part(s). For example, construct a tractor on a farm, a space shuttle with lunar module, windmill and house, etc.

- Exhibit should be a scene that includes moveable parts.
- Exhibit must be no taller than 36 inches high.
- Exhibit must rest on sturdy base which is no more than 36 inches square. It can be smaller.
- Blocks may be glued together, but it's not mandatory.
- Members should construct a more advanced project each year.
- Members have the option of constructing a poster displaying their architectural model, along with related information, in place of displaying the actual model.



ARTS AND CRAFTS, GENERAL: MODEL RAILROADING

No State Fair Exhibits *County Project*

Division 1—Grade 3	Division 6—Grade 8
Division 2—Grade 4	Division 7—Grade 9
Division 3—Grade 5	Division 8—Grade 10
Division 4—Grade 6	Division 9—Grade 11
Division 5—Grade 7	Division 10—Grade 12



Manual:

- 4-H Model Railroad Club Summary Guide for Fulton County

Poster Guidelines:

All posters, notebooks, and display boards must include a reference list indicating where information was obtained, giving credit to the original author, to complete the 4-H member's exhibit. This reference list should/might include web site links, people and professionals interviewed, books, magazines, etc. It is recommended this reference list be attached to the back of a poster or display board, be the last page of a notebook, or included as part of the display visible to the public. A judge is not to discredit an exhibit for the way references are listed.

Posters are to be 22"x28" and displayed horizontally and placed in a clear plastic sleeve or covered with clear plastic to protect contents. Display boards should be designed to sit on a table using no more than 36" of tabletop space. Space should be left in the lower right-hand corner to place an exhibit tag provided by Purdue Extension staff.

Judges evaluating exhibits should recognize individual differences and creativity, therefore using information in this document as a guide rather than a requirement.

Divisions 1 and 2—Brakeman

Project Completion: Turn in completed record sheet

Exhibit: See Model Railroading Information and Exhibit section at the end of Divisions 9 and 10.

Select one of the following:

- A poster explaining parts of a railroad car and how they work
- OR a Skill Level 1 train car kit

Divisions 3 and 4—Hand Brakeman

Project Completion: Turn in completed record sheet

Exhibit: See Model Railroading Information and Exhibit section at the end of Divisions 9 and 10.

Select one of the following:

- A model of a railroad car made from a Skill Level 2 kit
- OR a model of a building made from a Skill Level 2 kit

Divisions 5 and 6—Fireman

Project Completion: Turn in completed record sheet

Exhibit: See Model Railroading Information and Exhibit section at the end of Divisions 9 and 10.

Select one of the following:

- A railroad car made from a Skill Level 3 model kit
- OR a building made from a Skill Level 3 model kit
- OR use weathering and details for a Skill Level 2 kit

Divisions 7 and 8—Engineer

Project Completion: Turn in completed record sheet

Exhibit: See Model Railroading Information and Exhibit section at the end of Divisions 9 and 10.

Select one of the following:

- A railroad car made from a Skill Level 3 model kit adding details and weathering
- OR a building made from a Skill Level 3 model kit adding weathering and details.

Division 9 and 10—Conductor

Project Completion: Turn in completed record sheet

Exhibit: See Model Railroading Information and Exhibit section at the end of Divisions 9 and 10.

Select one of the following:

- A railcar made from a Master Craftsman kit
- OR a building made from a Master Craftsman kit
- OR 16 inches wide by two (2) feet long diorama showing a railroad industry.
- OR scratch build a building car or locomotive from plans you have drawn. Include your plans.

Model Railroad Information and Exhibit Section

- Completed Record Sheet is due when project is entered at project judging.
- All models will be judged according to the National Model Railroad Association Form No. 902.
- Any NMRA scale of Model Railroading may be used.
- The term buildings include: models like water towers, cranes, etc.
- Each exhibitor will get a 16" x 24" display board. This will be used to show exhibit: car, building, diorama, etc. (Ask leader for details)
- If a member shows financial need and would be willing to donate his or her project to the club after the fair the member may work with the leaders to complete the project.
- Members should help with club activities and fundraisers to assist in purchasing new train materials.

ARTS AND CRAFTS, GENERAL: RECYCLING

No State Fair Exhibit *County Project*

The goal of this project is for youth to understand what recycling means and the benefits and importance of the practice.

Beginner:	Grades 3, 4, & 5
Intermediate:	Grades 6, 7, & 8
Advanced:	Grades 9, 10, 11, & 12



Manual:

- Fulton County 4-H Recycling Project

Project Completion: Turn in a completed Recycling Record Sheet to finish the project.

Exhibit:

- An article or display made of discarded items or recycled products such as paper, plastic, aluminum, cloth, etc.
- All materials used must be recycled or repurposed except for bonding agents.
- No materials used in the items should be of a hazardous nature, i.e. old batteries, chemical containers, or anything with mercury.
- The object of the Recycling project is to re-use items on hand that are no longer of value. When planning your project, keep in mind that at least 75% of your project needs to be from recycled items. (Paint/finishes are not included in the 75%). The higher the percentage of recycled materials used the better.
- The project should be different and more advanced each year.

ARTS AND CRAFTS, GENERAL: SCARECROW

No State Fair Exhibits *County Project*

This is a “Family” project which may include father, mother, single parent, grandparents, guardian, sisters, brothers, etc.

Beginner: Grades 3, 4, & 5
 Intermediate: Grades 6, 7, & 8
 Advanced: Grades 9, 10, 11, & 12

Manual:

- Fulton County 4-H Scarecrow Project

Project Completion: Turn in the completed Scarecrow Record Sheet to finish the project. It should be turned in at judging.

Exhibit: A scarecrow

- Limit of one (1) scarecrow per family.
- Scarecrows may be made out of any type of building materials such as wood, metal, or plastic. Any type of clothing material may be used.
- Exhibit shall not be taller than 5 feet or wider than 4 feet.
- Exhibit must be constructed so that it can be hung with an appropriately attached hanger OR design your own stand to support or hold your scarecrow. A “T” type construction is easiest and recommended.
- Must be functional (durable) for field (outdoor) use. Any type of clothing material may be used including traditional farm apparel.
- A new scarecrow must be made each year. The stand, however, may be reused.



AQUATIC SCIENCE



No State Fair Exhibit

Beginner (Grades 3-5)	Intermediate (Grades 6-8)	Advanced (Grades 9-12)
Fish Bowl up to 1 gallon	Fish Bowl up to 1 gallon	Fish Bowl up to 1 gallon
1-5 Gallon Aquarium	5-10 Gallon Aquarium	5-10 Gallon Aquarium

Judging and Check-In:

- Check-in will be the 1st Saturday of the fair from 9:00-10:00 a.m. with judging immediately following.
- Exhibitor name cards may be attached to the table in front of the tank or bowl.
- There will be one (1) Champion and one (1) Reserve Champion for each of the following divisions:
 - Beginner Fish Tanks (Grades 3-5)
 - Intermediate Fish Tanks (Grades 6-8)
 - Advanced Fish Tanks (Grades 9-12)
 - Fish Bowl
- There will be one (1) overall Grand Champion and one (1) Reserve Grand Champion chosen from the Champions and Reserve Champions

Exhibit Guidelines for Fish Bowls:

1. Any fish bowl, tank, or betta bowl; no larger than one (1) gallon in size.
2. One (1) fish may be exhibited in the fish bowl.
3. Gravel, plants, decorations, and backing are all optional.

Beginner Tanks—Grades 3-5

Exhibit Guidelines for Tanks or Aquariums:

1. One (1) tank 1-5 gallons in size
2. One (1) fish, or one (1) pair of fish
3. Use a plain or solid color backing for your tank
4. Plants, gravel, and decorations are optional



Intermediate Tanks—Grades 6-8

Exhibit Guidelines for Tanks or Aquariums:

1. One (1) tank 5-10 gallons in size
2. Community tank—the number of fish should be proportionate to the size of the tank
 - The rule of thumb on this is 1” of fish per gallon of water
3. Member must provide all equipment needed for their tank
 - Lights, filter, heater, etc.
4. Gravel and a background are required
5. Plants and lighting are recommended, but are not required.

Advanced Tanks—Grades 9-12

Exhibit Guidelines for Tanks or Aquariums:

1. One (1) tank 5-10 gallons in size
2. Tanks should fall into one of the following categories
 - Natural—use only natural accessories and plants
 - Artificial—use only artificial accessories and plants
 - Breeding/Spawning tank—must be fish the exhibitor has spawned, 7 or more fish are recommended
3. For all advanced categories:
 - Background and gravel are required
 - Lighting, plants, and decorations are recommended but not required
 - Member must provide all necessary equipment for their exhibit
 - Lights, filters, heater, etc.
 - The number of fish should be proportionate to the size of the tank. 1” of fish per gallon of water.

BICYCLE

Description:

The 4-H bicycle project teaches safe riding habits.

State Fair Entries:

No state fair entries.

Exhibit Guidelines:

All posters, notebooks, and display boards must include a reference list indicating where information was obtained, giving credit to the original author, to complete the 4-H member's exhibit. This reference list should/might include web site links, people and professionals interviewed, books, magazines, etc. It is recommended this reference list be attached to the back of a poster or display board, be the last page of a notebook, or included as part of the display visible to the public. A judge is not to discredit an exhibit for the way references are listed.

Posters are to be 22"x28" and displayed horizontally and placed in a clear plastic sleeve or covered with clear plastic to protect contents. Display boards should be designed to sit on a table using no more than 36" of tabletop space. Space should be left in the lower right hand corner to place an exhibit tag provided by Purdue Extension staff.

Judges evaluating exhibits should recognize individual differences and creativity, therefore using information in this document as a guide rather than a requirement.

Exhibit Class Guidelines:

Educational Exhibits

Beginner (grades 3-5 suggested)

Create an educational poster, notebook or display about a bicycle topic of choice that is age/grade appropriate.

Intermediate (grades 6-8 suggested)

Create an educational poster, notebook or display about a bicycle topic of choice that is age/grade appropriate.

Advanced (grades 9-12 suggested)

Create an educational poster, notebook or display about a bicycle topic of choice that is age/grade appropriate.

Section 1.01 *Riding Skills Option (grades 3-12)*

Some county 4-H programs offer group rides and/or an obstacle course to develop safe riding habits and skills. Check with your county 4-H educator to learn more.

BOOKS

(Listed under Collections & Hobbies)



No State Fair Exhibits

Beginner:	Grades 3, 4, & 5
Intermediate:	Grades 6, 7, & 8
Advanced:	Grades 9, 10, 11, & 12

Manual:

- Books Project—Fulton County

Members will select a module from those listed in the manual, and then complete all requirements and activities for their division. The module selected must be one that has not been chosen by the 4-Her in a previous year.

Beginner—Grades 3, 4, & 5

Project Completion: Turn in completed record sheet to finish the project.

Exhibit: Read three books chosen from the selected module. The books should be appropriate for the 4-Her's age and ability level.

1. Complete two activities from the activity list. The activities may not be ones that have been completed by the member in a previous year.
2. Exhibit a poster. The exhibit should reflect the module selected by the 4-Her. Refer to Poster requirements in your manual.

Intermediate—Grades 6, 7, & 8

Project Completion: Turn in completed record sheet to finish the project.

Exhibit: Read four books chosen from the selected module. The books should be appropriate for the 4-Her's age and ability level.

1. Complete two activities from the activity list. The activities may not be ones that have been completed by the member in a previous year.
2. Exhibit a poster. The exhibit should reflect the module selected by the 4-Her. Refer to Poster requirements in your manual.

Advanced—Grades 9, 10, 11, & 12

Project Completion: Turn in completed record sheet to finish the project.

Exhibit: Read five books chosen from the selected module. The books should be appropriate for the 4-Her's age and ability level.

1. Complete two activities from the activity list. The activities may not be ones that have been completed by the member in a previous year.
2. Exhibit a poster. The exhibit should reflect the module selected by the 4-Her. Refer to Poster requirements in your manual.

All posters, notebooks and display boards must include a reference list indicating where information was obtained, giving credit to the original author, to complete the 4-H member's exhibit. This reference list should/might include website links, people and professionals interviewed, books, magazines, etc. It is recommended that this reference list be attached to the back of a poster or display board, be the last page of a notebook, or included as part of the display visible to the public.

Posters are to be 22"x28" and displayed horizontally and placed in a clear plastic sleeve or covered with clear plastic to protect contents. Display boards should be designed to sit on a table using no more than 36" of tabletop space. Space should be left in the lower right-hand corner to place an exhibit tag provided by Purdue Extension staff.

Judges evaluating exhibits should recognize individual differences and creativity, therefore using information in this document as a guide rather than a requirement.

BOTTLE ROCKETS

(Listed under Aerospace)

No State Fair Exhibits

Division 1—Grades 3, 4, & 5

Division 2—Grades 6, 7, & 8

Division 3—Grades 9, 10, 11, & 12

Manual:

- Fulton County Two Liter Bottle Rockets Manual

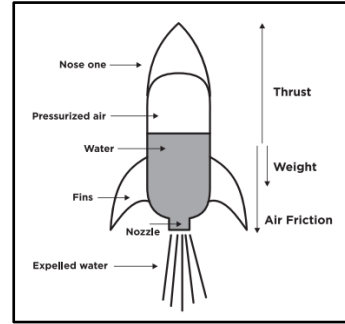

Each member will be given an opportunity to launch their rocket. Bottle rockets are judged on how they are decorated.

Division 1—Grades 3, 4, & 5

Project Completion: Turn in completed record sheet to finish the project.

Exhibit: Members will construct a Bottle Rocket using a single 2-liter soft drink bottle.

- Plans for the fins and nose cone will be provided. No other fin or nose cone design may be used.
- The rocket may be decorated in any manner.
- Fins, nose cones, and other items should be made from cardboard or lightweight plastic (not metal).

Division 2—Grades 6, 7, & 8

Project Completion: Turn in completed record sheet to finish the project

Exhibit: Members will construct a Bottle Rocket using a single bottle of any size.

- In order to be launched the bottle rocket must fit properly on the launcher.
- Fins and nose cone may be of any design.
- The rocket may be decorated in any manner.
- Fins, nose cones, and other items should be made from cardboard or lightweight plastic (not metal).

Division 3—Grades 9, 10, 11, & 12

Project Completion: Turn in completed record sheet to finish the project.

Exhibit: Member will construct a multistage rocket using any size bottle.

- In order for the rocket to be launched the lower bottle must fit on the launcher.
- Fins and nose cone may be of any design.
- Only the lower bottle will be pressurized.
- The rocket may be decorated in any manner.
- Fins, nose cones and other items should be made from cardboard or lightweight plastic (not metal).

It is recommended you provide your own display rack, if you use more than 3 bottles.

CAKE DECORATING

State Fair Project—Champion from each level to State Fair (3)

Beginners:	Grades 3, 4, & 5
Intermediate:	Grades 6, 7, & 8
Advanced:	Grades 9, 10, 11, & 12



Guidelines for Judging:

- Cake Decorating Record Sheet
- Cake Decorating Level Skill Sheet

No Manual

- Choose skills from the **Indiana 4-H Cake Decorating Skills and Techniques Sheet, (4-H 710)A**

Exhibit Introduction:

- The cake decorating project provides skills-based educational experiences that provide an opportunity for mastery before building on that experience to develop more advanced skills. This subject area is divided into three levels:
 - Beginner (Grades 3-5)
 - Intermediate (Grades 6-8)
 - Advanced (Grades 9-12)

While the defined grades are intended to be a guide, older youth enrolled in this subject for the first time may start in a lower grade skill level with permission by the county extension educator, followed by an appropriate level the following year.

- Skills and techniques demonstrated should be age/grade appropriate. While it is not to say a beginner level member cannot master an advanced level skill, it would be rare and unique. **Therefore, exhibited cakes must demonstrate the minimum five techniques from their given level outlined in Indiana 4-H Cake Decorating Skills and Techniques, 4-H 710A**, but may also include higher/lower level techniques that have been mastered. Any higher/lower level techniques will not be counted as part of the minimum five, but nevertheless will be evaluated for quality.
- All exhibited cakes must be created using a Styrofoam, foam, or other solid dummy.
- Unless otherwise stated, cakes are to be iced using royal icing or buttercream. Buttercream icing will not withstand environmental conditions and may become soft, melt, not withhold its shape, and colors may bleed when being displayed an extended period of time.
- When displaying a cut-up cake or tiered cake, the exhibitor must include a diagram and description indicating how the cake was assembled. This diagram and description can be attached to or written on the skills sheet. **All exhibits must include a completed Cake Decorating Skills Sheet (4-H 710) and must accompany the cake for the judge's reference during judging.** Skills sheets are for judging purposes only and will not be returned to the exhibitor.
- Judges evaluating exhibits should recognize individual differences and creativity, therefore using information in this document as a guide rather than a requirement.

Beginner—Grades 3-5

- A minimum of five beginner level skills are to be demonstrated. A list of skills to choose from can be found on the **Indiana 4-H Cake Decorating Skills and Techniques, 4-H 710A sheet**.
- Cakes must be on a cake board strong enough to support the cake (approximately 3/8" thick) and 2-4" larger than the cake. For example, if the cake is 8" in diameter, then the cake board must be 10-12" in diameter. The cake board must be neatly covered and well-taped or otherwise attached underneath.
- Cakes exhibited in the beginner level are to be a single tier/layer no more than 5" tall, and may be round, square, or rectangular and the cake board is to be no more than 12" x 12".

Intermediate—Grades 6-8



- A minimum of five intermediate level skills are to be demonstrated and the cake may include additional skills from the beginner level. A list of skills to choose from can be found on the **Indiana 4-H Cake Decorating Skills and Techniques, 4-H 710A sheet**.
- Cakes must be on a cake board strong enough to support the cake (approximately 3/8" thick) and 2-4" larger than the cake. For example, if the cake is 9" x13" rectangular, then the cake board must be 11" x15" to 13" x17" rectangular. The cake board must be neatly covered and well-taped or otherwise attached underneath.
- Cakes exhibited in the intermediate level are to be a single or double tier/layer, no more than 12" tall and may be any shape. Youth may choose to decorate an inverted (upside down) character pan or create a 3-dimensional cake. It is also permissible to cup up pieces of Styrofoam, foam, or other solid material to create a new shape, like a butterfly or castle for example. The cake board is to be no more than 24" x 24".

Advanced—Grades 9-12

- A minimum of five advanced level skills are to be demonstrated and the cake may include additional skills from the beginner and intermediate levels. A list of skills to choose from can be found on the **Indiana 4-H Cake Decorating Skills and Techniques, 4-H 710A sheet**.
- Cakes must be on a cake board strong enough to support the cake (approximately 1/2" thick) and 4" larger than the base cake. For example, if the cake is 26" in diameter, then the cake board must be 30" in diameter. The cake board must be neatly covered and well-taped or otherwise attached underneath.
- Cakes exhibited in the advanced level may be multiple layer and/or tiered and may include multiple cakes, like a wedding cake. Youth may choose to create a character or 3-dimensional cake by cutting up pieces of Styrofoam, foam, or other solid material to create a new shape.
- Dowel rods, plates, etc. should be used to support multiple layers and tiers.
- Fondant icing, gum, and sugar paste is permissible.
- Cakes may be any shape, no more than 36" tall and the cake board is to be no more than 36" x 36".



Cat: CAT POSTER

State Fair—1 champion from each level exhibits at State Fair

- Level 1: Grades 3, 4, & 5
- Level 2: Grades 6, 7, & 8
- Level 3: Grades 9, 10, 11, & 12

Guideline for Judging:

- General Record Sheet

Cat Manual:

- Level 1: Purr-fect Pals
- Level 2: Climbing Up!
- Level 3: Leaping Forward



Exhibit Guidelines:

Owning or showing an animal is not required. Members enrolled in any 4-H animal or livestock project can exhibit in this project and are to contact their county 4-H educator to learn if they are to also be enrolled in animal education.

All posters, notebooks, and display boards must include a reference list indicating where information was obtained, giving credit to the original author, to complete the 4-H member's exhibit. This reference list should/might include web site links, people and professionals interviewed, books, magazines, etc. It is recommended this reference list be attached to the back of a poster or display board, be the last page of a notebook, or included as part of the display visible to the public. A judge is not to discredit an exhibit for the way references are listed.

Posters are to be 22"x28" and displayed horizontally and placed in a clear plastic sleeve or covered with clear plastic to protect contents. Display boards should be designed to sit on a table using no more than 36" of tabletop space. Space should be left in the lower right-hand corner to place an exhibit tag provided by Purdue Extension staff.

Judges evaluating exhibits should recognize individual differences and creativity, therefore using information in this document as a guide rather than a requirement.

Level 1—Grades 3-5

Project Completions: Turn in a completed record sheet with your poster.

Exhibit: Create an educational poster, notebook or display about any manual activity or on any specie related topic of choice that is age/grade appropriate. Check with the Purdue Extension office in your county to determine if enrollment is required in the species project you want to learn about. Owning or possessing an animal is not required. Suggested educational exhibit topics may include but are not limited to:

- Cat care
- Cat breeds
- Litter-training
- Cat responsibilities
- Grooming skills
- Training my cat
- Neutering or spaying
- Determining cat costs
- Traveling with my cat
- Treating my cat with care and respect
- My cat's safety

Level 2—Grades 6-8

Project Completions: Turn in a completed record sheet with your poster.

Exhibit: Create an educational poster, notebook or display about any manual activity or on any specie related topic of choice that is age/grade appropriate. Check with the Purdue Extension office in your county to determine if enrollment is required in the species project you want to learn about. Owning or possessing an animal is not required. Suggested educational exhibit topics may include but are not limited to:

- National cat fancier associations
- A cat clinic
- Training with extra praise
- Careers related to cats
- Should my cat have kittens?
- Feeding my cat
- Things I've learned
- Insect pests
- Symptoms of ill health
- My visiting pet therapy program
- Cats get old too!
- Saying good-bye

Level 3—Grades 9-12

Project Completions: Turn in a completed record sheet with your poster.

Exhibit: Create an educational poster, notebook or display about any manual activity or on any specie related topic of choice that is age/grade appropriate. Check with the Purdue Extension office in your county to determine if enrollment is required in the species project you want to learn about. Owning or possessing an animal is not required.

Suggested educational exhibit topics may include but are not limited to:

- Understanding a cat show
- Planning a cat business
- Cat genetics
- Cat organs and systems
- Exploring careers
- Learning about leadership
- Teaching others
- Having fun learning
- Protecting our environment
- Issues of animal welfare/rights



CHILD DEVELOPMENT

State Fair—1 Champion for each level to State Fair.

Level A: Grades 3 & 4

Level B: Grades 5 & 6

Level C: Grades 7, 8, & 9

Level D: Grades 10, 11, & 12

Description:

Youth will learn about developmental stages of infants, toddlers and young children.



Child Development Manual:

- Level A: Building a Bright Beginning
- Level B: Building Blocks of Learning
- Level C: Building a Strong Foundation
- Level D: Building Relationships Toward a Brighter Tomorrow

Project Completion Guidelines:

- Child Development Record Sheet

Exhibit Guidelines:

All posters, notebooks, and display boards must include a reference list indicating where information was obtained, giving credit to the original author, to complete the 4-H member's exhibit. This reference list should/might include web site links, people and professionals interviewed, books, magazines, etc. It is recommended this reference list be attached to the back of a poster or display board, be the last page of a notebook, or included as part of the display visible to the public. A judge is not to discredit an exhibit for the way references are listed.

Posters are to be 22"x28" and displayed horizontally and placed in a clear plastic sleeve or covered with clear plastic to protect contents. Display boards should be designed to sit on a table using no more than 36" of tabletop space. Space should be left in the lower right-hand corner to place an exhibit tag provided by Purdue Extension staff.

Activities may be designed to be displayed on the floor, but please be considerate of space availability. Each item is to be labeled with the 4-H member's name, county and club so fair staff can keep all components together if it needs to be moved after judging is complete.

Notebooks are to include the following:

- Identifications on the front showing 4-H member's name, county, club, grade and year in project.
- Title page naming the activity.
- Pages explaining how activity was developed and is to be used.
- Photographs showing how the activity was used along with assembly.
- Explanation of skills learned and any additional information to share with the reader.

Judges evaluating exhibits should recognize individual differences and creativity, therefore using information in this document as a guide rather than a requirement.

Level A—Grades 3 & 4

Exhibit:

- Exhibit a poster, display, or notebook about a manual activity. Other similar activities are permissible.
- Turn in your Child Development record sheet

Level B—Grades 5 & 6

Exhibit:

- Exhibit a poster, display, or notebook about a manual activity. Other similar activities are permissible.
- Turn in your Child Development record sheet

Level C—Grades 7, 8, & 9

Exhibit:

- Exhibit a poster, display, or notebook about a manual activity.
- **OR** other similar activities are designed to help develop physical, emotional, or cognitive skills are permissible.
- Turn in your Child Development record sheet

Level D—Grades 10, 11, & 12

Exhibit:

- Exhibit a poster, display, or notebook about a manual activity.
- **OR** other similar activities are designed to help develop physical, emotional, or cognitive skills are permissible.
- Turn in your Child Development record sheet

COLLECTIONS & HOBBIES

No State Fair Exhibit

- Level A: Grades 3 & 4
- Level B: Grades 5 & 6
- Level C: Grades 7, 8, & 9
- Level D: Grades 10, 11, & 12

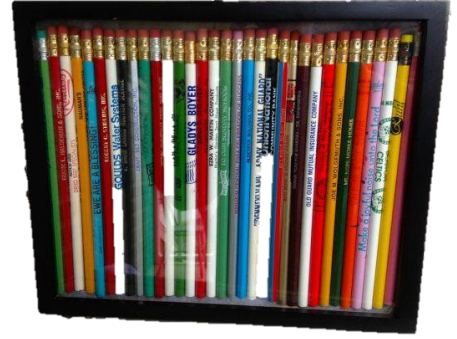

Manual:

- Fulton County Collections Manual

Guidelines for judging:

- Collections notebook that includes:
 - Your collection story
 - Collection question sheet
 - Record Sheet
- Include previous year's record sheet and information
- Members receiving Grand Champion may continue to add to their collection but must exhibit at least 5 new pieces and indicate in their notebook they were a previous Grand Champion.

Level A—Grades 3 & 4

Exhibit at least 3 pieces of your collection along with your completed notebook.

- Pieces should be different each year.
- Add to your notebook each year so you will be able to show the growth of your collection.

Level B—Grades 5 & 6

Exhibit at least 3 pieces of your collection along with your completed notebook.

- Pieces should be different each year.
- Your story should be more detailed and informative than the Level A story.
- Add to your notebook each year so you will be able to show the growth of your collection.

Level C—Grades 7-9

Exhibit at least 3 pieces of your collection along with your completed notebook.

- Pieces should be different each year.
- Your story should be more detailed and informative than the Level B story.
- Add to your notebook each year so you will be able to show the growth of your collection.

Level D—Grades 10-12

Exhibit at least 3 pieces of your collection along with your completed notebook.

- Pieces should be different each year.
- Your story should be more detailed and informative than the Level C story.
- Add to your notebook each year so you will be able to show the growth of your collection.

Collection projects will not be accepted for items that have their own 4-H project areas. Leaves, insects, and rocks may not be entered in the collection project. These should be entered in the proper project area—Forestry, Entomology, or Geology. Collections should not contain materials deemed inappropriate for youth collections. For example: alcoholic beverage can/bottles are not appropriate for the 4-H Collection Project.

Use an attractive display not to exceed 3' wide x 2' deep x 2' high outside measurement. You will need to attach the 5½" x 3" project label (provided by the office) to your display and the notebook.

After selecting the type of items you are going to collect, keep a record of how your collection grows by filling out the "4-H Collector's Record Sheets." This is very important because your record sheets are to be displayed with your collection at the county fair. The record sheets are also judged.

CONSUMER CLOTHING

State Fair exhibits:

One from Beginners, Intermediates, Advanced each level

One from the advanced level to model in State Fair Fashion Revue.

Beginner:	Grades 3, 4, & 5
Intermediate:	Grades 6, 7, & 8
Advanced:	Grades 9, 10, 11, & 12



Manual:

- Consumer Clothing: Beginner
- Consumer Clothing: Intermediate
- Consumer Clothing: Advanced

Guidelines for judging:

- Consumer clothing Record Sheet
- Notebook—3 ring binder

All posters, notebooks, and display boards must include a reference list indicating where information was obtained, giving credit to the original author, to complete the 4-H member's exhibit. This reference list should/might include web site links, people and professionals interviewed, books, magazines, etc. It is recommended this reference list be attached to the back of a poster or display board, be the last page of a notebook, or included as part of the display visible to the public. A judge is not to discredit an exhibit for the way references are listed.

The front of the notebook is to include the 4-H member's name, county, club, and level. Personal information such as phone number, mailing address, etc. should not be included in any notebook documentation.

Youth will be expected to model their purchased outfit and accessories at the county level. Modeling at state fair is limited to only the advanced level and will be judged separate from the notebook.

Judges evaluating exhibits should recognize individual differences and creativity, therefore using information in this document as a guide rather than a requirement.

Beginners—Grades 3, 4, & 5

1. Complete one activity from each group in the manual and share your results or answers in a notebook, labeling each activity.
2. With help from a parent or mentor, purchase an item of clothing that you'll wear with other clothes in your wardrobe. Examples might be slacks, blouse, jeans, shirt, sweater, or sweatshirt.
3. Choose an accessory to go with your purchase. Accessories could be shoes, sweatband, belt, jewelry, socks or similar item.

Intermediates—Grades 6, 7, & 8

1. Complete one activity from each group in the manual and share your results or answers in a notebook, labeling each activity.
2. Purchase and accessorize a casual or school outfit. Accessories may be purchased or selected from what you currently have.

Advanced—Grades 9, 10, 11, & 12

1. Complete one activity from each group in the manual, or similar activity of choice and share your results or answers in a notebook, labeling each activity.
2. If completing an activity not included in the manual, be sure to include in your notebook an explanation describing how the activity was developed and intended objectives.
3. Purchase and accessorize an outfit of your choice. Accessories may be purchased or selected from what you currently have.

Special note regarding Indiana State Fair – In addition to the advanced consumer clothing state fair entry submitting their notebook for evaluation, the exhibitor will also be invited to model their purchased outfit in fashion revue. The notebook and modeling will be judged independently and one will not have any consideration for the other at state fair.



CROPS

No State Fair Exhibits *County Projects*

All crops may be exhibited at the fair. All crops exhibits must have been produced in the current crop season on the 4-Her's farm. There are no divisions, just judged by the type of crop.

Corn

Project Completion: Turn in completed record sheet to finish the project.

Exhibit: Exhibit two stalks—roots and all.

- Roots must be in a ball of dirt.
- The corn stalks should be in a bucket or pail.



Hay

Project Completion: Turn in completed record sheet to finish the project.

Exhibit: Alfalfa—Mixed—Grass—Exhibit one slab in clear plastic.



Silage

Project Completion: Turn in completed record sheet to finish the project.

Exhibit: Exhibit one gallon of silage in one of the following classes. The container is to be clear.:

- Corn Silage
- Legume Silage
- Legume—Grass Mixture



Soybeans

Project Completion: Turn in completed record sheet to finish the project.

Exhibit: Exhibit six stalks of beans, roots and all

- Washed
- In a pail of water



Wheat

Project Completion: Turn in completed record sheet to finish the project.

Exhibit: Exhibit one quart of grain

- In order to complete, (only if crop is not mature) exhibit 8-inch bundle of stalks, roots and all, in a small plastic bag.



CUPCAKE DECORATING *(Listed under Cake Decorating)*

No State Fair Exhibits *County Project*

- Beginner: Grades 3, 4, & 5
 Intermediate: Grades 6, 7, & 8
 Advanced: Grades 9, 10, 11, & 12



Manual:

- Fulton County Cupcake Decorating Manual

All Divisions:

- Turn in Completed Record Sheet
- Skills Card must be attached to your display.**
- All projects must be on a solid base such as cardboard or wood that is approximately 3/8" thick and is not more than 3 inches larger than the cupcake display. Boards should be covered.
- Cupcakes must be attached to the exhibit as to not allow them to be picked up.
- Icing must be used on your project. Cupcakes will not be judged on taste.
- All cupcakes exhibited must meet the specific level requirements (no more, no less) or they will be scored down a ribbon.
- Styrofoam dummy cupcakes are an option if an exhibitor does not want to use real cake.
- Cupcakes will be judged on creative decorating, technique, instruction, construction, and appearance according to guidelines for each level.

Beginner—Grades 3, 4, & 5

Exhibit:

- Display 6 individual decorated cupcakes, all decorated alike, in uniform appearance.
- Cupcakes must be displayed in a single layer on a solid surface, not to exceed 16 x 16 inches in exhibit size.
- The Skills Card must be attached to the board.
- All items used for decorating must be edible.
- Artificial/added sprinkles, candies or cookies may be used, but no artificial items may be used.
- Each year should be a little more challenging.



Intermediate—Grades 6, 7, & 8

Exhibit:

- Display 6-16 cupcakes decorated in a theme.
- Cupcakes may be decorated individually or as a group as long as the theme is carried out in your display.
- Cupcake display area must not exceed 18 x 18 inches in exhibit size. Cupcakes must be presented on a solid base in a single layer.
- The Skills Card must be attached to the board.
- Smooth or decorate top with added edible sprinkles, candies, cookies, etc., that incorporate your theme. No artificial items may be used.



Advanced—Grades 9, 10, 11, & 12

Exhibit:

- Display 12-24 cupcakes decorated in a theme.
- Cupcakes may be decorated individually, or as a group as long as the theme is carried out in your display.
- Cupcake displays are must not exceed 24 x 24 inches in exhibit size. Your cupcakes must be presented on a solid base in a single layer.
- The Skills Card must be attached to the board.
- Smooth or decorate top with added edible sprinkles, candies, cookies, etc. that incorporate your theme. Artificial items may be used in this division.



DO YOUR OWN THING

(Listed under Collections & Hobbies)

No State Fair Exhibit

- Beginner: Grades 3, 4, & 5
 Intermediate: Grades 6, 7, & 8
 Advanced: Grades 9, 10, 11, & 12

Manual:

- Fulton County Do Your Own Thing Manual

You may do one of the following:

- Develop a project not now offered in 4-H
- Exhibit a 4-H project that is **NOT** offered in Fulton County. Examples include: Beekeeping, Computer, Plant Science, and Strawberries.
- Take an existing 4-H project but change its exhibit to your interest
- The exhibit should be one that could not be exhibited in any other project.



All Divisions

Project Completion: Turn in a completed record sheet.

Exhibit: Choose one of the following for your exhibit:

- A display or object that you made
- A notebook or scrapbook
- A 22" x 28" poster on a subject of your choice. Exhibit must be accompanied by the record sheet to further explain your exhibit.

All posters, notebooks and display boards must include a reference list indicating where information was obtained, giving credit to the original author, to complete the 4-H member's exhibit. This reference list should/might include website links, people and professionals interviewed, books, magazines, etc. It is recommended that this reference list be attached to the back of a poster or display board, be the last page of a notebook, or included as part of the display visible to the public.

Posters are to be 22"x28" and displayed horizontally and placed in a clear plastic sleeve or covered with clear plastic to protect contents. Display boards should be designed to sit on a table using no more than 36" of tabletop space. Space should be left in the lower right-hand corner to place an exhibit tag provided by Purdue Extension staff.

Judges evaluating exhibits should recognize individual differences and creativity, therefore using information in this document as a guide rather than a requirement.



Dog: DOG POSTER

State Fair—1 Champion from each level to State Fair

Level 1:	Grades 3, 4, & 5
Level 2:	Grades 6, 7, & 8
Level 3:	Grades 9, 10, 11, & 12



Manual:

- Level 1: Wiggles and Wags
- Level 2: Canine Connection
- Level 3: Leading the Pack

Exhibit Guidelines:

Owning or showing an animal is not required. Members enrolled in any 4-H animal or livestock project can exhibit in this project and are to contact their county 4-H educator to learn if they are to also be enrolled in animal education.

All posters, notebooks, and display boards must include a reference list indicating where information was obtained, giving credit to the original author, to complete the 4-H member's exhibit. This reference list should/might include web site links, people and professionals interviewed, books, magazines, etc. It is recommended this reference list be attached to the back of a poster or display board, be the last page of a notebook, or included as part of the display visible to the public. A judge is not to discredit an exhibit for the way references are listed.

Posters are to be 22"x28" and displayed horizontally and placed in a clear plastic sleeve or covered with clear plastic to protect contents. Display boards should be designed to sit on a table using no more than 36" of tabletop space. Space should be left in the lower right-hand corner to place an exhibit tag provided by Purdue Extension staff.

Judges evaluating exhibits should recognize individual differences and creativity, therefore using information in this document as a guide rather than a requirement.

Level 1—Grades 3-5

Project Completions: Turn in a completed record sheet with your poster.

Exhibit: Create an educational poster, notebook or display about any manual activity or on any specie related topic of choice that is age/grade appropriate. Check with the Purdue Extension office in your county to determine if enrollment is required in the species project you want to learn about. Owning or possessing an animal is not required.

Suggested Exhibit Topics but not limited to:

- Importance of dogs to people
- A schedule for taking care of a dog
- How to choose a dog for your family
- Breeds of dogs, advantages and disadvantages of owning a "mutt"
- How to keep your dog safe
- The external anatomy of a dog
- The major nutrients a dog needs to be healthy
- Vaccinations
- How to housetrain
- Dog behavior
- How to groom

Level 2—Grades 6, 7, & 8

Project Completions: Turn in a completed record sheet with your poster.

Exhibit: Create an educational poster, notebook or display about any manual activity or on any specie related topic of choice that is age/grade appropriate. Check with the Purdue Extension office in your county to determine if enrollment is required in the species project you want to learn about. Owning or possessing an animal is not required.

Suggested Exhibit topics but not limited to:

- Origins of dog breeds
- Choosing a boarding kennel
- Genetic problems
- Selecting the right dog food
- A healthy dog check-up
- Dog parasites
- Spaying or neutering
- Ethics of raising and caring for dogs
- Obedience training

Level 3—Grades 9, 10, 11, & 12

Project Completions: Turn in a completed record sheet with your poster.

Exhibit: Create an educational poster, notebook or display about any manual activity or on any specie related topic of choice that is age/grade appropriate. Check with the Purdue Extension office in your county to determine if enrollment is required in the species project you want to learn about. Owning or possessing an animal is not required.

Suggested Exhibit Topics but not limited to:

- Checking a dog's vital signs
- Canine digestive system and function
- Dog breeding
- Taking care of older dogs
- Puppy training
- Guide dogs
- Careers with dogs
- Laws related to dogs
- Dog to people diseases

ELECTRIC

State Fair—1 Champion from each level to State Fair

- Level 1
- Level 2
- Level 3
- Level 4
- Level 5 (Grades 7-12)

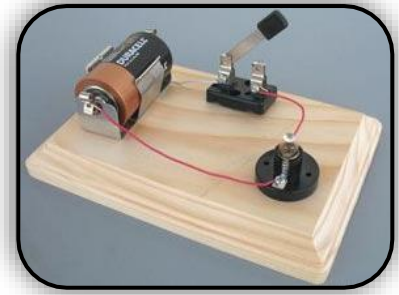

Manuals that are available:

- Level I: Magic of Electricity, Level 1
- Level II: Investigating Electricity, Level 2
- Level III: Wired for Power, Level 3
- Level IV: Lighting the Way
- Level V—Advanced: Entering Electronics
- Old manuals may be used—new ones are not required. There will be activity sheets for Levels I-V on the following 4-H Website: <https://extension.purdue.edu/4h/Pages/project.aspx?proj=27>

Exhibit Guidelines:

All posters, notebooks, and display boards must include a reference list indicating where information was obtained, giving credit to the original author, to complete the 4-H member's exhibit. This reference list should/might include web site links, people and professionals interviewed, books, magazines, etc. It is recommended this reference list be attached to the back of a poster or display board, be the last page of a notebook, or included as part of the display visible to the public. A judge is not to discredit an exhibit for the way references are listed.

Posters are to be 22"x28" and displayed horizontally and placed in a clear plastic sleeve or covered with clear plastic to protect contents. Display boards should be designed to sit on a table using no more than 36" of tabletop space. Space should be left in the lower right-hand corner to place an exhibit tag provided by Purdue Extension staff.

Youth are encouraged to complete the activities as instructed in the manual or found on the [4-H electric web page](https://extension.purdue.edu/4-H/projects/4-h-project-electric.html). You may use this web address: <https://extension.purdue.edu/4-H/projects/4-h-project-electric.html>

Judges evaluating exhibits should recognize individual differences and creativity, therefore using information in this document as a guide rather than a requirement.

Electric Level 1 (1st year in Electric)

Exhibit:

- One article of choice displaying proper wiring techniques, made during the current 4-H program year. It must demonstrate a minimum of five (5) or more of the appropriate level of "Skills to be Attained" items as outlined in the "4-H Electric and Electronic Skills & Knowledge Chart".
- A completed copy of the "Exhibit Skills & Knowledge Sheet" must accompany the project. Skills sheets are for judging purposes only and will not be returned to the exhibitor.

Exhibit Suggestions:

- Circuit board – 6" by 6" of Series/Parallel Circuit
- Electromagnet
- Galvanometer
- Poster board (22" by 28")
- Display (appropriately sized for displayed equipment)
- Notebook/Report that covers any topic that is in the National 4-H Electric Curriculum Electricity Excitement Book 1 or Investigating Electricity Book 2, Purdue Extension website Level 1 activities/project sheets, or from the appropriate level of the Skills & Knowledge Chart.

Electric Level 2 (2nd year in Electric)

Exhibit:

- One article of choice displaying proper wiring techniques, made during the current 4-H program year. It must demonstrate a minimum of five (5) or more of the appropriate level of **“Skills to be Attained” items as outlined in the “4-H Electric and Electronic Skills & Knowledge Chart”**.
- **A completed copy of the “Exhibit Skills & Knowledge Sheet” must accompany the project.** Skills sheets are for judging purposes only and will not be returned to the exhibitor.

Exhibit Suggestions:

- Magnetic Powered Shake Flashlight – with display
- Circuit board – 6” by 6” of Series/Parallel Circuit (with modifications if exhibited in Level 1)
- Electromagnet
- Galvanometer
- Electric Motor
- Poster board (22” by 28”)
- Display (appropriately sized for displayed equipment)
- Notebook/Report that covers any topic that is in the National 4-H Electric Curriculum Electricity Excitement Book 1 or Investigating Electricity Book 2, Purdue Extension website Level 2 activities/project sheets, or from the appropriate level of the Skills & Knowledge Chart.

Electric Level 3 (3rd year in Electric)

Exhibit:

- One article of choice displaying proper wiring techniques, made during the current 4-H program year. It must demonstrate a minimum of five (5) or more of the appropriate level of **“Skills to be Attained” items as outlined in the “4-H Electric and Electronic Skills & Knowledge Chart”**.
- **A completed copy of the “Exhibit Skills & Knowledge Sheet” must accompany the project.** Skills sheets are for judging purposes only and will not be returned to the exhibitor.

Exhibit Suggestions:

- Wiring Project – (ie. extension cord, trouble light, wire sizes and uses, plug configurations, test equipment, etc.)
- Electrical tool and supply kit
- Poster board (22” by 28”)
- Display (appropriately sized for displayed equipment)
- Notebook/Report that covers any topic that is in the National 4-H Electric Curriculum Wired for Power Book 3, Purdue Extension website Level 3 activities/project sheets, or from the appropriate level of the Skills & Knowledge Chart.

Electric Level 4 (4th year in Electric)

Exhibit:

- One article of choice displaying proper wiring techniques, made during the current 4-H program year. It must demonstrate a minimum of five (5) or more of the appropriate level of **“Skills to be Attained” items as outlined in the “4-H Electric and Electronic Skills & Knowledge Chart”**.
- **A completed copy of the “Exhibit Skills & Knowledge Sheet” must accompany the project.** Skills sheets are for judging purposes only and will not be returned to the exhibitor.

Exhibit Suggestions:

- Wiring – Wire a lamp. The lamp can be a re-wired lamp or one that is built new.
- Electrical tool and supply kit
- Poster board (22” by 28”)
- Display (appropriately sized for displayed equipment)
- Notebook/Report that covers any topic that is in the National 4-H Electric Curriculum Wired for Power Book 3, Purdue Extension website Level 4 activities/project sheets, or from the appropriate level of the Skills & Knowledge Chart.

Electric Level 5 (5th year or more in Electric)

Exhibit:

- One article of choice displaying proper wiring techniques, made during the current 4-H program year. It must demonstrate a minimum of five (5) or more of the appropriate level of “Skills to be Attained” items as outlined in the “4-H Electric and Electronic Skills & Knowledge Chart”.
- A completed copy of the “Exhibit Skills & Knowledge Sheet” must accompany the project. Skills sheets are for judging purposes only and will not be returned to the exhibitor.

Exhibit Suggestions:

- Equipment Wiring – including but not limited to: parts identification, appliance repair, lamps and other lighting, equipment wiring, control system, security system, topic that covers safety, motors/generators, electric heating, heat pumps, AC, water heaters, and other electric equipment.
- Home Wiring – included by not limited to any circuits found in the wiring of a house or “barn”, service entrance, switching, receptacles, generator transfer circuit, safety, electrical math, and others.
- Electronic Equipment – Any project or kit containing transistors or integrated circuits or vacuum tubes such as radio, TV, computer, robot, cell phone, and others.
- Poster board (22” by 28”)
- Display (appropriately sized for displayed equipment)
- Notebook/Report that covers any topic that is in the National 4-H Electric Curriculum Entering Electronics, Purdue Extension website Level 5 activities/project sheets, or from the appropriate level of the Skills & Knowledge Chart.
- Video Presentation Create a video showing the work accomplished and skills learned. This video should include the same type of information as required in written notebook listed above. This video is to be no more than ten minutes in length and formatted as MP4 and submitted on a thumb drive. This video can also be uploaded to a YouTube account with the video being made public and the link submitted for evaluation.

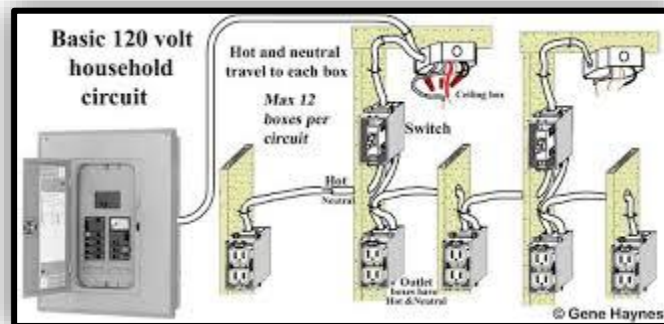
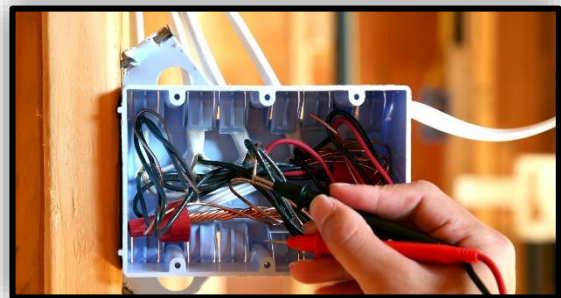
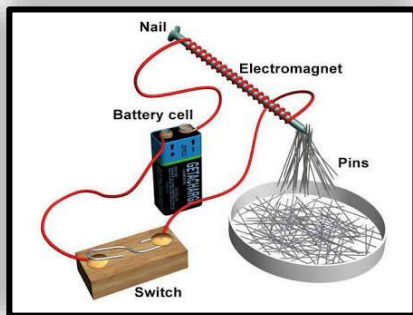

ENTOMOLOGY

State Fair—1 Insect Collection and 1 Poster from each level

- 3 collection exhibits per county, one per level
- 3 educational exhibits per county, one per level



Description:

This project will help you study insects and their relationship with people. You can also learn how to collect, preserve, and identify insects.

Manuals:

- Level 1
- Level 2
- Level 3

Educational Exhibit Guidelines:

All posters, notebooks, and display boards must include a reference list indicating where information was obtained, giving credit to the original author, to complete the 4-H member's exhibit. This reference list should/might include web site links, people and professionals interviewed, books, magazines, etc. It is recommended this reference list be attached to the back of a poster or display board, be the last page of a notebook, or included as part of the display visible to the public. A judge is not to discredit an exhibit for the way references are listed.

Posters are to be 22"x28" and displayed horizontally and placed in a clear plastic sleeve or covered with clear plastic to protect contents. Display boards should be designed to sit on a table using no more than 36" of tabletop space. Space should be left in the lower right-hand corner to place an exhibit tag provided by Purdue Extension staff.

Judges evaluating exhibits should recognize individual differences and creativity, therefore using information in this document as a guide rather than a requirement.

Collection Exhibit Guidelines: Collections are to include the following:

- **Title as Insect Collection**
- **Order** – refer to ID-401, page 57.
- **Display** – mounted insects are to have been legally and personally collected in the United States and displayed in an 18"x24" collection box displayed horizontally. Collections including multiple boxes are to be numbered 1 of 3, etc. ID 401 A-F cards (for grades 3-8) and 401-I cards (for grades 9 - 12) are to be placed inside the display box in an attractive manner.
- **Identification** – Collection display boxes are expected to contain the specified number of insects, families, and orders specified (see chart below). All insects must be in the adult stage and be properly mounted on insect pins or be contained in vials as directed.
- **Pin Labels** - Each pin or vial must contain two labels:
 - 1) Top label is to include collection date, location, and collector name.
 - 2) Bottom label is to include common name and other optional identification data.
- **Box Labels** – Box labels (computer generated or neatly printed) are used for orders and families as required (see chart below) and are to be placed flat against the bottom of the box. Insects must be properly grouped directly under the correct order and family label. For example, all insects belonging to a particular order must be placed under that order label. Orders to be used are listed in the reference book ID- 401. If family level identification is required, the insects should be further grouped together under family label.

- **Educational Box** – One additional box (educational), based on the specific theme (see chart below), is required for grades 9-12, in addition to the insect collection boxes. This box can be created in any manner chosen (without the mounting, pinning or identifying restrictions specified above).
- **Judges evaluating collection exhibits should judge based on educational content, scientific accuracy, eye appeal and creativity.**

Beginner (1st-3rd Year in Entomology)

Create a collection based on the year in Entomology or an educational exhibit.

Year in Entomology	Collection Information	Total Boxes
1 st year	10 insects, identified and pinned on cards (ID 401A)	1
2 nd year	20 insects, mounted (pins or vials). Identify all insects by common name and identify five (5) to order. Include card ID 401B.	1
3 rd year	30 insects, mounted (pins or vials). Identify all insects by common name and identify 15 to order. Include ID 401C.	1

Intermediate (4th-6th Year in Entomology)

Create a collection based on the year in Entomology or an educational exhibit.

Year in Entomology	Collection Information	Total Boxes
4 th year	40 insects, exhibit a minimum of 6 orders, mounted (pins or vials). Identify all insects by common name and order. Include ID 401D.	2
5 th year	50 insects, exhibit a minimum of 8 orders, mounted (pins or vials). Identify all insects by common name and order. Identify ten (10) to family. Include card ID 401E.	2
6 th year	60 insects, exhibit a minimum of 10 orders, mounted (pins or vials). Identify all insects by common name and order. Identify 30 to family. Include card ID 401F.	2

Advanced (7th-10th Year in Entomology)

Create a collection based on the year in Entomology or an educational exhibit. Advanced level insect collections are to also include an education box, for a total of four boxes. Advanced level youth may instead create an independent study topic of choice.

Year in Entomology	Collection Information	Total Boxes
7 th year	70 insects, exhibit a minimum of 12 orders, mounted (pins or vials). Identify all insects by common name, order, and family. One educational box, theme: insect behavior. Include card ID 401I. (1-3 collection boxes plus 1 educational box*). Place ID 401I in first collection box only. Card ID 401I download	3
8 th year	80 insects, exhibit a minimum of 14 orders, mounted (pins or vials). Identify all insects by common name, order, and family. One educational box, theme: insect pest management. Include card ID 401I. (1-3 collection boxes plus 1 educational box*). Place ID 401I in first collection box only. Card ID 401I download	3
9 th year	90 insects, exhibit a minimum of 16 orders, mounted (pins or vials). Identify all insects by common name, order, and family. One educational box, theme: insects in the environment. Include card ID 401I. (1-3 collection boxes plus 1 educational box*). Place ID 401I in first collection box only. Card ID 401I download	3
10 th year	100 insects, exhibit a minimum of 18 orders, mounted (pins or vials). Identify all insects by common name, order, and family. One educational box, theme: benefits of insects. Include card ID 401I. (1-3 collection boxes plus 1 educational box*). Place ID 401I in first collection box only. Card ID 401I download	3

FASHION REVUE

State Fair—6 Senior exhibits per county with no more than two exhibits per category.

Note – State Fair Fashion Revue grand champion will be selected from the six senior sewing category champions modeling their sewn garment or outfit plus the advanced consumer clothing champion modeling their purchased outfit.

This project teaches youth skills to present themselves in a professional manner by providing an opportunity for youth to model the outfit constructed in the 4-H sewing project.



County Level Fashion Revue

1. All Consumer Clothing and Sewing members who make wearable sewing projects are eligible to participate in the 4-H Fashion Revue.
2. Garments modeled must have been made following the 2021 State Fair.
3. **Each 4-H Sewing Junior (Grades 3-7) participant** may model only one outfit in the 4-H Fashion Revue, at least one garment of which has been made for and judged for 4-H sewing Construction.
4. **Each 4-H Sewing Senior (Grades 8-12) participant** may create and model an outfit in a maximum of 2 categories in the Fashion Revue.
5. At the **county** level, judges will select a champion and reserve champion in each category/division.
6. *Awards for 4-H Sewing Construction and 4-H Fashion Revue will be awarded at the public 4-H Fashion Revue as selected by the judges. 4-H members are eligible for awards in all categories in which they have exhibited. If a 4-H Sewing Senior participant wins in more than one Fashion Revue category, he/she must choose only one category to model in at the State Fair.*
7. **Judges will rank 4-H Sewing Senior Fashion Revue category participants** to determine State Fair eligibility.
8. Following public review and prior to deadline for State Fair entry, the winner must designate which category he/she will choose to compete in at the State Fair, if he/she wins both Fashion Revue and Construction.

Exhibit Guidelines:

All garments and outfits modeled in Fashion Revue, except consumer clothing entries, must have been constructed by the 4-H member modeling that same garment or outfit. Youth qualifying to exhibit the same garment or outfit in Indiana State Fair Sewing and Fashion Revue must choose which project they wish to participate as one cannot exhibit the same garment or outfit in both projects at state fair.

DEFINITION OF AN OUTFIT: An outfit is a garment or garments that when put together make a complete look - such as one- or two-piece dress, or one- or two-piece pant suit, or a three-piece combination, such as pants, vest, and blouse or shirt.

Judges evaluating exhibits should recognize individual differences and creativity, therefore using information in this document as a guide rather than a requirement.

Exhibit Class Guidelines:

Junior (grades 3-7 suggested)

Model the garment or outfit constructed for the sewing project. Accessories may be purchased or selected from what you currently have.

Senior Categories (grades 8-12 suggested)

- **Informal or Casual Wear:** A complete outfit of 1 or 2 pieces suitable for school, weekend, or casual, informal activities. A complete outfit is defined as a garment or garments that when put together make a complete look - such as one- or two-piece dress, or one- or two-piece pant suit, or a three-piece combination, such as pants, vest, and blouse or shirt.
- **Dress Up:** This is suitable for special, church, or social occasions that are not considered to be formal. It may be an outfit of one or more pieces with or without its own costume coat or jacket (lined or unlined). This is not an outfit that would be worn to school, weekend, or casual, informal activities.
- **Free Choice:** A complete outfit comprised of garments that do not fit in the other classifications. A complete outfit is defined as a garment or garments that when put together make a complete look - such as one- or two-piece dress, or one- or two-piece pant suit, or a three-piece combination, such as pants, vest, and blouse or shirt. Individual garment examples include: tennis wear, swim wear, athletic or sportswear, lounge wear, riding habits, historic, dance, theatrical, or international costumes, capes, and unlined coats.
- **Suit or Coat:** The suit consists of two pieces including a skirt or pants and its own lined jacket. It is not a dress with jacket as in "dress up wear". The coat is a separate lined coat. It will be judged separately as a coat with its own accessories.
- **Separates:** Consists of three garments that must be worn as a coordinated complete outfit. A complete outfit is defined as a garment or garments that when put together make a complete look - such as one- or two-piece dress, or one- or two-piece pant suit, or a three-piece combination, such as pants, vest, and blouse or shirt. Each piece should be versatile enough to be worn with other garments.
- **Formal Wear:** This outfit may be one or more pieces suitable for any formal occasion, such as proms, weddings, and formal evening functions.

FLORICULTURE

State Fair Entries: Youth will learn basic information and skills needed to grow healthy plants and flowers as well as floral design techniques.

- 8 floral exhibits per county, 2 per level
- 4 educational exhibits per county, 1 per level

Exhibit Classes

- Level A—Grades 3 & 4
- Level B—Grades 5 & 6
- Level C—Grades 7, 8, & 9
- Level D—Grades 10, 11, & 12

Requirements for Judging:

- Floriculture Record Sheet

Manual

- 4-H Floriculture, Level A
- 4-H Floriculture, Level B
- 4-H Floriculture, Level C
- 4-H Floriculture, Level D



Note to Youth Exhibitors:

Each Level (A, B, C, & D) of the Floriculture project serves more than one grade. You should do a DIFFERENT activity and exhibit each year that you are in the project. For example, if in 3rd grade, you display a simple bud vase (category 1), in 4th grade, you should choose a poster/notebook option or flower/plant exhibit from categories 2, 3, or 4. You should pay special attention to size guidelines for Flower and Plant exhibits. Instruction for exhibits and related activities can be found in the 4-H Floriculture student manuals: 4-H 966, 967, 968, and 969.

Exhibit Guidelines:

All posters, notebooks, and display boards must include a reference list indicating where information was obtained, giving credit to the original author, to complete the 4-H member's exhibit. This reference list should/might include web site links, people and professionals interviewed, books, magazines, etc. It is recommended this reference list be attached to the back of a poster or display board, be the last page of a notebook, or included as part of the display visible to the public. A judge is not to discredit an exhibit for the way references are listed.

Posters are to be 22"x28" and displayed horizontally and placed in a clear plastic sleeve or covered with clear plastic to protect contents. Display boards should be designed to sit on a table using no more than 36" of tabletop space. Space should be left in the lower right hand corner to place an exhibit tag provided by Purdue Extension staff.

Floral arrangements can be constructed using fresh flowers and greenery grown yourself or purchased, flowers and greenery dried yourself or purchased, or artificial flowers or greenery.

Judges evaluating exhibits should recognize individual differences and creativity, therefore using information in this document as a guide rather than a requirement.

Level A (grades 3-4 suggested)

Floral Option - Create a simple bud vase (1-3 stems of main flower plus appropriate filler and/or greenery) or simple round arrangement (small, compact round cluster of flowers plus appropriate filler and/or greenery).

Educational Display Option – Create a poster, notebook or display about one of the following:

1. Chronicle your work in your flower garden (planning, planting, care, harvest, arrangement made with your flowers)
2. Describe how you planned or designed your garden, including how you chose the kinds of flowers.
3. Explain how you harvested your flowers, cared for them, and used them in an arrangement.
4. Explore and explain: pollination - what it is, why important, different ways it occurs or transplanting - what, how, things to watch out for; or role of insects with flowers (good, bad or both).
5. Explore and explain seed germination.
6. Explore and explain how to care for a 'sick' plant.
7. Report on interview with a floriculture professional (what do they do, types of jobs, type of training, hours worked, etc.)
8. Describe an experiment you did and the results.
9. Describe a community service project you did related to your flowers project.
10. Another similar activity.

Level B (grades 5-6 suggested)

Floral Option – Create a mixed planter that includes 3 or more kinds of plants, make an item from dried plants, or display a house plant (flowering or non-flowering) you've grown.

Educational Display Option – Create a poster, notebook or display about one of the following:

1. Report how you harvested your flowers and/or herbs, cared for them, dried them, and used them.
2. Explore and explain: insects and your flowers and/or herbs.
3. Explore and explain: starting seeds indoors -- the process and pros and cons.
4. Explore and explain: perennials -- what are they, how are they used, benefits or drawbacks.
5. Investigate and describe a butterfly garden -- what types of plants, benefits to insects and butterflies, etc.
6. Describe how you planned or designed your garden, including how you chose the kinds of plants, any problems, successes.
7. Describe your houseplant - how you cared for, transplanted to larger pot, any problems, or successes.
8. Explore and explain: plant biology -- form and function, growth, photosynthesis, etc.
9. Explore and explain: how to grow plants indoors -- things to consider, common problems and solutions.
10. Explore and explain: environmental effects related to plants (such as light, water, soil, or temperature).
11. Describe an experiment you did and the results.
12. Explore and explain topics from "Imagine That" -- plants around the world, information about different cultural uses of plants, different ways you used your plants/herbs/flowers.
13. Another similar activity.

Level C (grades 7-9 suggested)

Floral Option – Create a terrarium, combination or European planter (3 or more kinds of plants), corsage, boutonniere, or specialty arrangement in a container (using dried flowers, roses, or lilies as the primary content).

Educational Display Option – Create a poster, notebook or display about one of the following:

1. Explore and explain: vegetative propagation -- how to, different types, problems and solutions, different uses of.
2. Explore and explain: plant nutrients -- what are they, why does the plant need them, what happens if the plant has too much or too little, planters or containers vs. garden.
3. Investigate the design of multiple plant containers -- how to, things to consider, selecting plant materials, uses of.
4. Describe how you created your corsage or boutonnieres; or dried arrangement. Be sure to include appropriate information on design principles and how they are used to create your arrangement.
5. Explore and explain: floral tools and materials (how to use, what they are, care of tools, different uses of a tool or material).
6. Explore and explain: preserving cut flowers -- how, problems, uses of and/or diseases related to cut flowers.
7. Illustrate, explore and explain how you dry flowers or other plant materials and/or describe different methods and/or how, why use them.
8. Explore and explain: medicinal uses and toxicity of fresh and dried flowers and plants.
9. Describe an experiment you did and the results.
10. Describe a career exploration activity you did, such as job shadow, interview with a professional.
11. Describe a community service activity you did related to your flowers project -- what you did, why, results, etc.
12. Another similar activity.

Level D (grades 10-12 suggested)

Floral Option – Create a seasonal arrangement, modern or contemporary arrangement, bridal bouquet, special occasion centerpiece, or plant you have propagated and grown yourself.

Educational Display Option – Create a poster, notebook or display about one of the following:

1. Describe how you created your arrangement, include information on the design principles utilized.
2. Explore and explain how you utilize different flowers to make a similar style arrangement for different seasons (tulips in spring, mums in fall, etc.) or how to utilize similar flowers to make different styles of arrangements.
3. Explore and explain: the cost of arrangement and/or a cost comparison with flowers (different types flowers, different time year, etc.).
4. Explore and explain: forcing flowers (bulbs, branches, etc.).
5. Explore and explain: marketing in the floral industry (large or small business) and/ or a market survey and results, and how they can benefit the floral industry.
6. Explore and explain: how to start a business related to the floral industry and may include a business plan.
7. Explore and explain the origins of flowers and/or the floriculture industry around the world.
8. Explore and explain: tissue culture, biotechnology, or traditional breeding of new flower types -- what are they, how are they used, pros and cons.
9. Explore and explain: be a plant detective -- what kinds of problems might you have in growing and caring for flowers, and how to solve.
10. Describe an experiment you did and the results.
11. Describe a community service activity you did related to your flowers project: how, why, results.
12. Another similar activity.

FOODS—BAKED

State Fair—Champion from each grade and activity to State Fair.

(Youth may bring one baked item and one preserved item as these are 2 separate projects)

Level A—Grades 3 & 4—2 entries per county

Level B—Grades 5 & 6—2 entries per county

Level C—Grades 7, 8, & 9—3 entries per county

Level D—Grades 10, 11, & 12—3 entries per county

Needed for Judging:

- Foods Record Sheet
- Recipe Card (Available online or at the Extension Office)

Manuals:

- Fantastic Foods, Level A
- Tasty Tidbits, Level B
- You're the Chef, Level C
- Foodworks, Level D



Exhibit Guidelines:

All posters, notebooks, and display boards must include a reference list indicating where information was obtained, giving credit to the original author, to complete the 4-H member's exhibit. This reference list should/might include web site links, people and professionals interviewed, books, magazines, etc. It is recommended this reference list be attached to the back of a poster or display board, be the last page of a notebook, or included as part of the display visible to the public. A judge is not to discredit an exhibit for the way references are listed.

Posters are to be 22"x28" and displayed horizontally and placed in a clear plastic sleeve or covered with clear plastic to protect contents. Display boards should be designed to sit on a table using no more than 36" of tabletop space. Space should be left in the lower right-hand corner to place an exhibit tag provided by Purdue Extension staff.

Purdue Extension Food Safety Policy (Revised 10/2020)

For Food Competitions:

- Fillings, frostings, glazes, and meringues are not permitted to contain cream cheese, sour cream, heavy cream, or whipped cream if they are not fully cooked/baked. These items are allowed as ingredients in food products if the final product is cooked/baked.
- Additionally, raw milk, raw milk products or uncooked eggs/egg whites are not permitted.
- Eggs/egg whites that have been cooked to 160°F (i.e. Pasteurized or included as part of a batter and baked) are acceptable.
- No home-canned fruits, vegetables, or meats are permitted as ingredients in food products.
- Fresh-cut, uncooked, fruits and/or vegetables are not permitted to be used in food products or used as garnishes for the product.
- Foods should be transported to the competition in a way that minimizes contamination and maintains the quality of the food (i.e. foods that are judged as frozen should remain frozen at all times).
- Recipes must be provided that identifies all ingredients that were used in each part of the product.
- Any ingredient that could be a potential allergen must be clearly identified. Potential food allergens include, but are not limited to, milk, eggs, peanuts, tree nuts, fish, crustacean shellfish, wheat, soy, and sesame.
- Each food product must be labeled with the following information:
 - Name
 - Address (4-H member information can be taken from enrollment if needed)

- Contact information (phone and/or email address; 4-H member information can be taken from enrollment if needed)
- Recipe with all ingredients listed
- Date the food product was made.
- Contestants should carefully wash their hands and make sure that their hands do not have any open cuts before preparing foods. If cuts are present, the wound should be bandaged and a single use food service glove worn on the hand during all stages of food production.
- Contestants should not be preparing food exhibits for competition with 48 hours of recovering from any illness.
- People experiencing symptoms of vomiting, diarrhea, fever, and/or jaundice should not be allowed to prepare food.
- Judges and individuals who will consume products from county and/or state competitions should be informed that they are at risk for foodborne illness since the established policy cannot guarantee that an entry has been properly prepared or handled before, during, or following the competition. The food products for competitions are home produced and processed and the production area is not inspected by the Indiana State Department of Health.
- Tasting of a food product is solely at the discretion of the judge and consumers. Judges are not to taste any home preserved foods such as low-acid or acidified foods like green beans, tomatoes or tomato products, jams/jellies/fruit preserves or fermented products produced in the home.
- Baked food products may be from a boxed mix following the instructions, a boxed mix with added ingredients, or ingredients combined from scratch. Youth are to place their name, county and club on the bottom side of their plate, pan, or other container and the official entry tag provided will be placed with the exhibit.
- A completed recipe card is to be submitted with each exhibit. Recipe cards are for judging purposes only and will not be returned to the exhibitor. Laminating, wrapping the recipe card in plastic, or placing it in a clear plastic bag is optional. Since it is illegal in the State of Indiana for youth under the age of 21 to purchase or consume alcoholic beverages, 4-H members are to use recipes that do not include an alcoholic beverage as an ingredient. A suitable non-alcoholic or imitation product may be substituted.
- Baked food products should be covered during transport and displayed on a paper or foam plate, or another type of disposable container. Pies, casseroles and other similar items are to be baked in a disposable pan. Cakes and sticky items may be displayed on a cardboard strong enough to support the item and covered in foil, plastic, wax paper, or similar substance.
- Judges evaluating exhibits should recognize individual differences and creativity, therefore using information in this document as a guide rather than a requirement.

Exhibit Class Guidelines:

Level A (grades 3-4 suggested)

Choose one or more of the baked products below, or a similar baked product of choice. It is suggested a participant choose a different option each year, but this is not a requirement. Exhibits entered at state fair will be donated to local homeless shelters after being judged and not displayed.

- Three uniced snack sized cookies.
- Three standard sized unlined muffins.
- Three standard sized unlined muffins containing an ingredient that is a source of Vitamin A or C.
- Three snack sized granola bars.
- Three snack sized brownies or blondies.
- An educational poster, notebook or display about a food or nutrition topic of choice that is age/grade appropriate.
- Any other similar baked item.

Level B (grades 5-6 suggested)

Choose one or more of the baked products below, or a similar baked product of choice. It is suggested a participant choose a different option each year, but this is not a requirement. Exhibits entered at state fair will be donated to local homeless shelters after being judged and not displayed.

- A single layer cake without frosting.
- A single layer reduced-fat cake without frosting. Reduce the amount of fat in the recipe by using a fruit puree or baby food fruit product that does not contain yogurt.
- A standard loaf-sized quick bread.
- A standard loaf-sized quick bread containing an ingredient that is a source of Vitamin A or C.
- A coffee-cake.
- A coffee-cake containing an ingredient that is a source of Vitamin A or C.
- Three biscuits or scones that are plain, sweet or savory.
- Three biscuits or scones that are plain, sweet or savory using a whole grain flour mixture.
- Three biscuits or scones that are plain, sweet or savory containing an ingredient that is a source of Vitamin A or C.
- Three no-yeast, any shape pretzels (shaped, stick or nugget).
- Three no-yeast, any shape pretzel with a whole grain flour mixture (shaped, stick or nugget).
- Three no-yeast breadsticks.
- Three no-yeast cinnamon rolls or other flavored roll without icing or glaze.
- A no-yeast sweet bread without icing or glaze.
- An educational poster, notebook or display about a food or nutrition topic of choice that is age/grade appropriate.
- Any other similar baked item.

Level C (grades 7-9 suggested)

Choose one or more of the baked products below, or a similar baked product of choice. It is suggested a participant choose a different option each year, but this is not a requirement. Exhibits entered at state fair will be donated to local homeless shelters after being judged and not displayed.

- Three yeast breadsticks or yeast rolls (any shape, medium size – not a sweet roll)
- Three (3) yeast breadsticks or yeast rolls (any shape, medium size - not a sweet roll), using a whole grain flour mixture. Participants are expected to learn how to knead bread dough by hand and allow it to rise appropriately. It is NOT acceptable to use a home bread maker.
- A yeast bread loaf or braid. Participants are expected to learn how to knead bread dough by hand and allow it to rise appropriately. It is NOT acceptable to use a home breadmaker.
- A yeast bread (can be loaf, braid) using a whole grain flour mixture such as whole wheat, rye, oat bran, etc. Participants are expected to learn how to knead bread dough by hand and allow it to rise appropriately. It is NOT acceptable to use a home breadmaker.
- Homemade pizza using a yeast dough. Judges are not expecting this item to be presented hot out of the oven.
- One package of an, invented healthy snack (such as a granola bar, popcornsnack, trail mix, etc.). Your snack must include at least 2 food groups from MyPlate. Exhibit must include your snack product and a separate folder containing a marketing plan with product name, recipe, how it will be packaged, a package design, where it will be sold and suggested selling price. Style your snack for a photo shoot and include the picture in your marketing plan. Label should include product name, date, quantity, and serving size.
- Prepare an entrée casserole that meets three MyPlate requirements for a meal. Use care when transporting to prevent spoilage. Judges are not expecting this casserole to be presented hot out of the oven.
- An educational poster, notebook or display about a food or nutrition topic of choice that is age/grade appropriate.
- Any similar baked item.

Level D (grades 10-12 suggested)

Choose one or more of the baked products below, or a similar baked product of choice. It is suggested a participant choose a different option each year, but this is not a requirement. Exhibits entered at state fair will be donated to local homeless shelters after being judged and not displayed.

- A single or double crust baked fruit pie (no graham cracker crust). (Note: Custards, cream, cream cheese frosting and fillings, and raw egg white frosting are not acceptable in an exhibit because they are highly perishable when left at room temperature.)
- A baked food product for a catered meal or special event in which organizers have requested low fat and/or reduced sugar items. Exhibit will include your food product and a notebook outlining how this product is to be used at the event, menu, supplies to buy, preparation schedule, equipment, table layout, etc. A table display is optional.
- Select a condition in which people have to specifically modify their eating habits (diabetes, heart disease, Celiac disease, food allergies, etc.) Prepare a baked food product appropriate for someone with this condition. Exhibit will include your food product and a notebook summarizing the condition or allergy, nutrition considerations involved with the condition, a description of your baked item, and an explanation of how it fits within the nutrition considerations. Make sure to note any ingredients that could cause an allergic reaction.
- Prepare an entrée casserole that meets four MyPlate requirements for a meal. Use care when transporting to prevent spoilage. Judges are not expecting this casserole to be presented hot out of the oven.
- An international or ethnic food of choice. This may be a cold or hot product. Use care when transporting to prevent spoilage. Judges are not expecting this product to be presented hot out of the oven.
- A specialty pastry.
- Create a baking mix and provide a sample of the baked product. Include an index card with instructions, wet ingredients needed, and baking instructions.
- An educational poster, notebook or display about a food or nutrition topic of choice that is age/grade appropriate.
- Any other similar baked item.

FOODS—PRESERVED

State Fair—Champion from each grade and activity to State Fair.

(Youth may bring one baked item and one preserved item as these are 2 separate projects)

Level A—Grades 3 & 4—2 entries per county

Level B—Grades 5 & 6—2 entries per county

Level C—Grades 7, 8, & 9—3 entries per county

Level D—Grades 10, 11, & 12—3 entries per county

Needed for Judging:

- Foods Record Sheet
- Recipe Card (Available online or at the Extension Office)

Manuals:

- Fantastic Foods, Level A
- Tasty Tidbits, Level B
- You're the Chef, Level C
- Foodworks, Level D



Exhibit Guidelines:

All posters, notebooks, and display boards must include a reference list indicating where information was obtained, giving credit to the original author, to complete the 4-H member's exhibit. This reference list should/might include web site links, people and professionals interviewed, books, magazines, etc. It is recommended this reference list be attached to the back of a poster or display board, be the last page of a notebook, or included as part of the display visible to the public. A judge is not to discredit an exhibit for the way references are listed.

Posters are to be 22"x28" and displayed horizontally and placed in a clear plastic sleeve or covered with clear plastic to protect contents. Display boards should be designed to sit on a table using no more than 36" of tabletop space. Space should be left in the lower right hand corner to place an exhibit tag provided by Purdue Extension staff.

Refer to the [Purdue Extension Food Preservation](#) website for resources and Purdue Extension educators trained to answer food preservation questions.

Purdue Extension Food Safety Policy (Revised 10/2020)

For Food Competitions:

- Fillings, frostings, glazes, and meringues are not permitted to contain cream cheese, sour cream, heavy cream, or whipped cream if they are not fully cooked/baked. These items are allowed as ingredients in food products if the final product is cooked/baked.
- Additionally, raw milk, raw milk products or uncooked eggs/egg whites are not permitted.
- Eggs/egg whites that have been cooked to 160°F (i.e. Pasteurized or included as part of a batter and baked) are acceptable.
- No home-canned fruits, vegetables, or meats are permitted as ingredients in food products.
- Fresh-cut, uncooked, fruits and/or vegetables are not permitted to be used in food products or used as garnishes for the product.
- Foods should be transported to the competition in a way that minimizes contamination and maintains the quality of the food (i.e. foods that are judged as frozen should remain frozen at all times).
- Recipes must be provided that identifies all ingredients that were used in each part of the product.
- Any ingredient that could be a potential allergen must be clearly identified. Potential food allergens include, but are not limited to, milk, eggs, peanuts, tree nuts, fish, crustacean shellfish, wheat, soy, and sesame.
- Each food product must be labeled with the following information:

- Name
 - Address (4-H member information can be taken from enrollment if needed)
 - Contact information (phone and/or email address; 4-H member information can be taken from enrollment if needed)
 - Recipe with all ingredients listed
 - Date the food product was made.
- Contestants should carefully wash their hands and make sure that their hands do not have any open cuts before preparing foods. If cuts are present, the wound should be bandaged and a single use food service glove worn on the hand during all stages of food production.
 - Contestants should not be preparing food exhibits for competition with 48 hours of recovering from any illness.
 - People experiencing symptoms of vomiting, diarrhea, fever, and/or jaundice should not be allowed to prepare food.
 - Judges and individuals who will consume products from county and/or state competitions should be informed that they are at risk for foodborne illness since the established policy cannot guarantee that an entry has been properly prepared or handled before, during, or following the competition. The food products for competitions are home produced and processed and the production area is not inspected by the Indiana State Department of Health.
 - Tasting of a food product is solely at the discretion of the judge and consumers. Judges are not to taste any home preserved foods such as low-acid or acidified foods like green beans, tomatoes or tomato products, jams/jellies/fruit preserves or fermented products produced in the home.
 - A completed recipe card is to be submitted with each exhibit. Recipe cards are for judging purposes only and will not be returned to the exhibitor. Laminating, wrapping the recipe card in plastic, or placing it in a clear plastic bag is optional. Since it is illegal in the State of Indiana for youth under the age of 21 to purchase or consume alcoholic beverages, 4-H members are to use recipes that do not include an alcoholic beverage as an ingredient. A suitable non-alcoholic or imitation product may be substituted.
 - Preserved food products should be displayed in an appropriate container, preferably disposable. Containers will not be returned to the exhibitor.
 - Judges evaluating exhibits should recognize individual differences and creativity, therefore using information in this document as a guide rather than a requirement.

Exhibit Class Guidelines:

Level A (grades 3-4 suggested)

Choose one or more of the preserved products below, or a similar preserved product of choice. It is suggested a participant choose a different option each year, but this is not a requirement. Exhibits entered at state fair will be donated to local homeless shelters and not displayed.

- A package of 3 baked or unbaked, snack-sized (approximately 2"-3" individual size) frozen cookies. Display in freezer bag or freezer container. (NOTE: Freezer containers will not be returned.) Include index card with recipe and instructions for defrosting or baking. Label with name of product, quantity, and date frozen.
- One package of frozen berries. Display in freezer bag or freezer container. (NOTE: Freezer containers will not be returned.) Include index card with recipe and instructions for cooking or defrosting. Label with name of product, quantity, and date frozen.
- One package of dehydrated fruit or vegetable. Display in an appropriate bag or container. Include index card with recipe and instructions for cooking or defrosting. Label with name of product, quantity, and date dehydrated.
- An educational poster, notebook or display about a food or nutrition topic of choice that is age/grade appropriate.
- Any other similar preserved item.

Level B (grades 5-6 suggested)

Choose one or more of the preserved products below, or a similar preserved product of choice. It is suggested a participant choose a different option each year, but this is not a requirement. A square, oblong or round layer cake. Exhibits entered at state fair will be donated to local homeless shelters and not displayed.

- One uncooked frozen mini-pizza using whole-grain pita bread, English muffin, bagel, or already prepared crust (no larger than 7" in diameter) with toppings of your choice. Include at least 4 MyPlate food groups on your pizza. Meat toppings such as hamburger, sausage, bacon, etc. must be cooked. Display on covered cardboard inside freezer bag. Include index card with recipe and instructions for cooking. Label with name of product, quantity, and date frozen.
- One package of any frozen vegetable or combination vegetables. Display in freezer bag or freezer container. (NOTE: Freezer containers will not be returned.) Include index card with instructions for defrosting and cooking. Label with name of product, quantity, and date frozen.
- One container of frozen fruit or vegetable juice. Include index card with instructions for defrosting and cooking. Label with name of product, quantity, and date frozen.
- One container of frozen soup. Include index card with recipe and instructions for defrosting and cooking. Label with name of product, quantity, and date frozen.
- A frozen ready-to-eat breakfast sandwich, burrito or similar item. Display on covered cardboard inside freezer bag. Include index card with recipe and instructions for cooking. Label with name of product, quantity, and date frozen.
- An educational poster, notebook or display about a food or nutrition topic of choice that is age/grade appropriate.
- Any other similar preserved item.

Level C (grades 7-9 suggested)

Choose one or more of the preserved products below, or a similar preserved product of choice. It is suggested a participant choose a different option each year, but this is not a requirement. Exhibits entered at state fair will be donated to local homeless shelters and not displayed.

- One (1) container of freezer jam. Include index card with recipe and instructions for storing. Label with name of product, quantity, and date frozen.
- One jar of a canned tomato product using the Hot Pack Method for a boiling water bath canner, such as tomato juice, catsup, barbecue sauce, or salsa. Include index card with recipe and instructions for cooking or using the product. Label with name of product, quantity, and date canned. Canned products must have the ring on the jar top to protect the seal. **Note: Only food preservation products made using USDA approved recipes and techniques are acceptable.**
- One jar of a canned pickled product or canned pickles. Include index card with recipe, processing, and storage instructions. (Products using a fancy pack are not accepted.) Label with name of product, quantity, and date canned. Canned products must have the ring on the jar top to protect the seal. **Note: Only food preservation products made using USDA approved recipes and techniques are acceptable.**
- Frozen yeast dough (bread loaf, roll balls, sticks, pizza, etc.). Include index card with recipe and instructions for defrosting and cooking. Label with name of product, quantity, and date frozen.
- An educational poster, notebook or display about a food or nutrition topic of choice that is age/grade appropriate.
- Any similar preserved item.

Level D (grades 10-12 suggested)

Choose one or more of the preserved products below, or a similar preserved product of choice. It is suggested a participant choose a different option each year, but this is not a requirement. Exhibits entered at state fair will be donated to local homeless shelters and not displayed.

- One jar of pressure canned vegetables, meat or combination product, such as soup, stew, spaghetti sauce with meat, etc. Include index card with recipe and instructions for cooking or using the product. (Products using a fancy pack are not accepted.) Label with name of product, quantity, and date canned. Canned products must have the ring on the jar top to protect the seal. ***Note: Only food preservation products made using USDA approved recipes and techniques are acceptable.***
- One package of a combination food frozen entree in freezer container. The combination food should contain 3 food groups from MyPlate. Exhibit should include an index card with recipe and instructions for reheating. Display in disposable containers. No containers will be returned. Label with name of product, quantity, and date frozen.
- A jar of cooked jam or a reduced-sugar fruit spread. Include recipe card. Label with name of product, quantity, and date made. ***Note: Only food preservation products made using USDA approved recipes and techniques are acceptable.***
- One container of a thaw and eat frozen prepared appetizer. Include index card with recipe and instructions for defrosting. Label with name of product, quantity, and date frozen.
- One container of a thaw and eat frozen prepared dessert. Include index card with recipe and instructions for defrosting. Label with name of product, quantity, and date frozen.
- An educational poster, notebook or display about a food or nutrition topic of choice that is age/grade appropriate.
- Any other similar preserved item.

FOODS—FUN WITH FOOD MIXES



No State Fair Exhibit

- Beginner: Grades 3, 4, & 5
- Intermediate: Grades 6, 7, & 8
- Advanced: Grades 9, 10, 11, & 12

Manual:

- Fulton County Manual—Fun with Food Mixes

Please Note—for baked product competitions:

- **Fillings, frostings, glazes, and meringues are not permitted to contain cream cheese, sour cream, heavy cream, or whipped cream if they are not fully cooked/baked.** These items are allowed as ingredients in food products if the final product is cooked/baked.
- Additionally, raw milk, raw milk products or uncooked eggs/egg whites are not permitted.
- Eggs/egg whites that have been cooked to 160°F (i.e. Pasteurized or included as part of a batter and baked) are acceptable.
- No home-canned fruits, vegetables, or meats are permitted as ingredients in food products.
- Fresh-cut, uncooked, fruits and/or vegetables are not permitted to be used in food products or used as garnishes for the product.
- Foods should be transported to the competition in a way that minimizes contamination and maintains the quality of the food (i.e. foods that are judged as frozen should remain frozen at all times).
- Recipes must be provided that identifies all ingredients that were used in each part of the product.
- Any ingredient that could be a potential allergen must be clearly identified.
- Each food product must be labeled with the following information:
 - Name
 - Recipe with all ingredients listed
 - Date the food product was made.
- Contestants should carefully wash their hands and make sure that their hands do not have any open cuts before preparing foods. If cuts are present, the wound should be bandaged and a single use food service glove worn on the hand during all stages of food production.
- Contestants should not be preparing food exhibits for competition with 48 hours of recovering from any illness.
- People experiencing symptoms of vomiting, diarrhea, fever, and/or jaundice should not be allowed to prepare food.
- Judges and individuals who will consume products from county and/or state competitions should be informed that they are at risk for foodborne illness since the established policy cannot guarantee that an entry has been properly prepared or handled before, during, or following the competition. The food products for competitions are home produced and processed and the production area is not inspected by the Indiana State Department of Health.
- Tasting of a food product is solely at the discretion of the judge and consumers. Judges are not to taste any home preserved foods such as low-acid or acidified foods like green beans, tomatoes or tomato products, jams/jellies/fruit preserves or fermented products produced in the home.

Judges and individuals who will consume products from county competitions should be informed that they are at risk for foodborne illness since the established policy cannot guarantee that an entry which may be a “potentially hazardous food” has been properly prepared or handled before during, or following the competition. Tasting of a food product is solely at the discretion of the judge. Judges are not to taste any low-acid or acidified preserved food and are discouraged from tasting any other home preserved food.

Labeling Suggestions:

- Cover label with clear plastic wrap so that it will not become grease stained.
- Tape the label to the paper plate or container before the product is wrapped.

Recipe or Index Cards:

- A recipe card or index card (no larger than 5½” x 8½”) is required for all food exhibits.

- Be sure to include the recipe source and all the information requested in the exhibit description, as well as your name, county, and grade level/exhibit option. It is recommended that you wrap the card in plastic wrap or in a plastic bag. Recipe cards will not be returned.
- Since it is illegal in the State of Indiana for youth under the age of 21 to purchase or consume alcoholic beverages, 4-H members are to use recipes that do not include an alcoholic beverage as an ingredient. A suitable non-alcoholic or imitation product may be substituted.

How to Prepare Products for Display:

- Most food products should be displayed on a paper or foam plate.
- For cakes—cut a piece of cardboard about ½ inch larger than the bottom of the cake. Cover this cardboard with wax paper, plastic wrap, or foil before putting the cake on it.
- Any product that may be sticky on the bottom, such as some fancy breads, should be put on round, square, or rectangle cardboard. Cover this cardboard with wax paper, plastic wrap, or foil before putting the product on it.

Beginner—Grades 3, 4, & 5

- 4-Hers are to exhibit a different cookie or brownie each year of the Beginner category
- Using a purchased mix by add at least two ingredients different than those listed on the package directions.
- Cookies or brownies may include a frosting and/or topping. See Baked Product paragraph at the end of the Advanced Division.
- **Exhibit** six baked, drop, molded, or bar cookies or brownies. Exhibit on paper plate or covered cardboard. **Be sure to include the product recipe on a 5” x 8” covered recipe card.**
- Recommended that you add 1 ingredient and frosting or ingredients. Frosting and sprinkles are acceptable.
- Turn in a completed record sheet with your exhibit.



Intermediate—Grades 6, 7, & 8

- 4-Hers are to exhibit a different cake or bread recipe in each year of the Intermediate category.
- Using a purchased mix, add at least two ingredients different from those listed on the package directions to create a bread or cake.
- Cake products may be round, square, rectangle, bundt, single- or double-layer and may include topping or frosting. (Yeast may be one of the added ingredients. Frosting and sprinkles do not count towards the added ingredients.)
- You may use a bread machine.
- **Exhibit** one (1) cake or bread or six (6) cupcakes. Display on a covered cardboard. **Turn in the recipe card and the original package directions with your exhibit for judge to determine if additional ingredients were added other than those listed on the package directions.** The recipe should be on a 5” x 8” covered recipe card.
- Turn in a completed record sheet with your exhibit.

Advanced—Grades 9, 10, 11, & 12

- 4-Hers are to exhibit a different recipe in each year of the advanced category.
- Using a purchased mix, add at least two ingredients different from those listed on the package directions to create an entrée, main dish, or side dish. (Yeast may be one of the added ingredients.)
- Exhibit the product in an appropriate glass or plastic cooking container—at least an 8” x 8” dish. Keep the product at the correct temperature until it is judged.
- You may use crock-pot, casserole, or soup mixes.
- You may use a bread machine.
- If exhibiting cookies, muffins, rolls, etc., exhibit six items
- Baked project may include a topping and/or frosting.
- To avoid loss of container, please label with your name or use a disposable container.
- **Turn in the recipe card and the original package directions with your exhibit for judge to determine if additional ingredients were added other than those listed on the package directions. The recipe should be on 5” x 8” covered recipe card.**
- Turn in a completed record sheet with your exhibit



FORESTRY

Champion from each level to State Fair

Level 1—Grades 3, 4, & 5

Level 2—Grades 6, 7, & 8

Level 3—Grades 9, 10, 11, & 12 or Independent Study

This project teaches youth natural resources and forestry related skills.

Judging:

- Turn in your Forestry Record Sheet with your project.

Manual:

- Level 1: Follow the Path
- Level 2: Reach for the Canopy
- Level 3: Explore the Deep Woods

Additional Materials Available:

- 50 Trees of Indiana

Exhibit Guidelines:

All posters, notebooks, and display boards must include a reference list indicating where information was obtained, giving credit to the original author, to complete the 4-H member's exhibit. This reference list should/might include web site links, people and professionals interviewed, books, magazines, etc. It is recommended this reference list be attached to the back of a poster or display board, be the last page of a notebook, or included as part of the display visible to the public. A judge is not to discredit an exhibit for the way references are listed.

Posters are to be 22"x28" and displayed horizontally and placed in a clear plastic sleeve or covered with clear plastic to protect contents. Display boards should be designed to sit on a table using no more than 36" of tabletop space. Space should be left in the lower right-hand corner to place an exhibit tag provided by Purdue Extension staff.

Judges evaluating exhibits should recognize individual differences and creativity, therefore using information in this document as a guide rather than a requirement.

Beginner Level 1—Grades 3, 4, & 5

Exhibit: Create an educational poster, notebook or display about any manual activity or on any forestry topic of choice that is age/grade appropriate. The following are examples from previous years.

- **Leafing Out**—Comparisons (pages 6 & 7)
 - Collect, dry, and mount 6 different species of leaves showing leaf differences: one leaf with opposite arrangement and one with an alternate arrangement, two leaves with different leaf margins, a compound leaf, and simple leaf.
 - Use the *50 Trees of Indiana* book (4-H 15-80 or CD FNR-3) as a reference and identify the leaves and group them under the titles of "arrangement," "leaf margins," and "compound or simple."
 - Draw (or copy the picture) and label the parts of a leaf using the diagram from the manual (Level 1).
 - Title your poster: **Leafing out—Leaf Differences.**
- **Leafing Out**—Collection (pages 6 & 7)
 - Identify and exhibit leaves from 10 different trees that are listed in *50 Trees of Indiana* book (4-H 15-80 or CD FNR-3).
 - List at least two unique characteristics of each tree.
 - Title your poster: **Leafing Out—Collection.**
- **Hold on Tight** (pages 10 & 11)
 - Dig up a small plant root system and display along with a drawing of the root system with the anchor, lateral, and feeder roots identified and the "Parts of a Tree" diagram (4-H 641B)

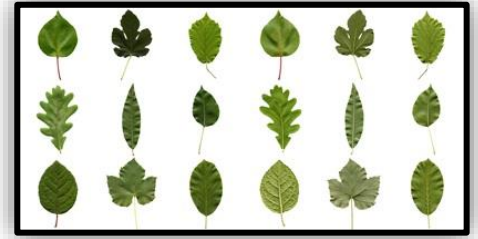

- **Down in the Dirt** (pages 20 & 21)
 - Collect roots from 3 different habitats: woods, near a creek, and in a pasture or prairie. (NOTE: Do not use the habitats listed in your manual.)
 - Display the roots along with the completed root test chart (copy or recreate) showing the color, size, and shape information. Include any unique features you noted.
- **My Couch is a Tree?** (pages 30 & 31)
 - Use pictures (drawn, cut from magazines, print, or take photographs) to show 10 things in and around your home that are made from wood.
- **Fun in the Forest** (pages 32 & 33)
 - Visit a state park or forest, take your *50 Trees of Indiana* book (4-H 15-80 or CD FNR-3), diagram the trails you hiked, and list the types of trees you saw.
 - Photographs of you hiking and some of the trees you saw will help tell your story.

Intermediate Level 2—Grades 6, 7, & 8

Exhibit: Create an educational poster, notebook or display about any manual activity or on any forestry topic of choice that is age/grade appropriate. The following are examples from previous years.

- **The Leaf Machine** (pages 8 & 9)
 - Copy, draw, or find a picture of a cross-section of a leaf. Label 7 parts.
 - Give the chemical reaction for photosynthesis, defining the chemicals: CO_2 , H_2O , O_2 , and $\text{C}_6\text{H}_{12}\text{O}_6$. Be sure to balance your equation! There should be the same number of Carbon, Oxygen, and Hydrogen molecules on each side of the equal sign. You may need to ask an older (high school) 4-H member or science teacher for help.
 - Draw the tree canopy, trunk, and roots (or use the tree diagram, 4-H 641B) and identify the crown, trunk (with the parts; heartwood, sapwood, cambium, and bark listed on the right), feeder roots, and anchor roots.
- **My State's Forests** (pages 14, & 14)
 - Use a map, draw, or find a picture of Indiana on the Internet (e.g., www.ingov/igic/). Show where your home, your school, and your fairgrounds are located.
 - Choose one of the following options to complete your poster:
 - Show where Indiana's state forests are located. List a few facts about each. Visit a state forest and have someone take your picture by the sign, if possible.
 - Show where some state parks and state forests are located (5-15). List some facts about each one. Visit a state park or forest and have someone take your picture by the sign, if possible.
- **Someone Call a (Tree) Doctor and Stop Bugging Me** (pages 22-25)
 - Collect 10 samples of tree leaves, twigs, stems, or roots damaged by insects or disease and the fruiting body or disease that caused the damage.
 - List information about the insect or disease and the species of tree that was affected.
- **Fire in the Forest** (pages 26 & 27)
 - Explain the Fire Triangle and describe what happened during and after a famous forest fire. Drawings or pictures will help tell the tale.
- **Growing Every Day** (pages 30 & 31)
 - Complete the table for 5 large trees that you can find and measure in your county.
 - Research to find out how to make and use a Tree Measuring Stick (FNR-4) and use that to calculate the volume of each tree. Explain why you think your results varied with the two methods of determining tree volume (the one in your 4-H manual or using a tree measuring stick).
- **Tree Planting** (Plant 1-3 shade trees)
 - Include information about the tree (or trees) you planted, why you chose the species you did, what are the benefits of this tree, and how tall this tree (or trees) will be when mature.
 - Explain why you chose the planting site that you did, where you found your planting information, what steps you followed, the hole size, care of your tree (watering and weed control), and any other information you can give.
 - Include a picture of your tree (photo or drawing). Reference: FNR-FAQ-18W.

Advanced Level 3—Grades 9, 10, 11, & 12

Exhibit: Create an educational poster, notebook or display about any manual activity or on any forestry topic of choice that is age/grade appropriate; prepare a herbarium collection that contains at least 25 native Indiana forest leaves; or prepare a herbarium collection that contains at least 25 native Indiana forest shrubs. Youth can also design and complete an independent study activity.

Herbarium Collections - Collect 25 terminal twigs and at least two leaves, if space allows (only one compound leaf is required), from native forest trees. Mount the specimens on 11 ½" x 16 ½" paper. One leaf on the twig must be mounted to show the back side of the leaf. Label each sheet with the following: common name, scientific name, where collected, county where collected, date collected, name of collector, and specimen number. Cover each specimen. There are no specific references given for these exhibits. Youth are encouraged to use Extension publications, the Internet, books, and forest specialists when collecting and identifying specimens. The herbarium collection must be accessible to the judges. Do not cover it under the plastic that covers your poster. Youth may want to attach a folder or other holder over your poster to hold the mounted, covered specimens.

GARDEN

State Fair Exhibits

- 1 collection per member, unlimited number of county entries
- 5 single vegetable entries per member, unlimited number of county entries.
- 3 herb entries per member, unlimited number of county entries.
- 1 potato tray entry per member, unlimited number of county entries.
- 1 tomato plate entry per member, unlimited number of county entries.

Needed for judging:

- Garden Record Sheet

Garden Manuals

- 4-H-1037—Garden Level A: See Them Sprout
- 4-H-1038—Garden Level B: Let's Get Growing
- 4-H 1039—Garden Level C: Take Your Pick
- 4-H-1040—Garden Level D: Growing Profits

Additional Materials Available

- 4-H-1041-W—Garden Helper's Guide
- 4-H-940-W—Suggested 4-H Garden Exhibits
- 4-H-970-W—4-H Garden Publication

Youth will learn about plant growth, soil nutrition, and management of insects and diseases related to fresh vegetable and herb production.

Exhibit Guidelines:

All posters, notebooks, and display boards must include a reference list indicating where information was obtained, giving credit to the original author, to complete the 4-H member's exhibit. This reference list should/might include web site links, people and professionals interviewed, books, magazines, etc. It is recommended this reference list be attached to the back of a poster or display board, be the last page of a notebook, or included as part of the display visible to the public. A judge is not to discredit an exhibit for the way references are listed.

Posters are to be 22"x28" and displayed horizontally and placed in a clear plastic sleeve or covered with clear plastic to protect contents. Display boards should be designed to sit on a table using no more than 36" of tabletop space. Space should be left in the lower right-hand corner to place an exhibit tag provided by Purdue Extension staff.

Refer to Suggested 4-H Garden Exhibits, 4-H 970-w, to learn about size, weight, and other suggested specifications.

Judges evaluating exhibits should recognize individual differences and creativity, therefore using information in this document as a guide rather than a requirement.

Guidelines—ALL LEVELS--Project Completion Recommendations

1. Read and study 4-H Garden manual(s)
2. Plan your garden
3. Select plants and seeds
4. Plant your garden
5. Care for your garden
6. Harvest your produce
7. Exhibit your produce
8. Try something new, as listed in the manual



9. Keep a complete record of your garden activities
10. Complete activities as required in the manual

Exhibit Guidelines

Single Vegetable

- May be selected from 4-H Garden Publication 4-H970W (updated yearly) or list in the State Fair Premium book.
- Maximum of 5 different single plate exhibits per exhibitor
- Single vegetable entries should be labeled with common name, Latin name, and variety of vegetable. The Latin names can be found in 4-H Garden Publication 4-H 970-W.

Example: Green Bean (*Phaseolus vulgaris*) 'Blue lake 47 Bush'

Garden Collection

Three (3) plates

Four (4) plates

Five (5) plates

- In all three classes, vegetables are to be exhibited on paper plates and may include a display of not less than three garden items, grown in your own garden.
- Exhibitors may each exhibit one collection (3 or 4 or 5 plate garden collection) at the State Fair.
- Garden collection entries should be labeled with common name, Latin name, and variety.
- Latin names can be found in 4-H Garden Publication 4-H 970-W.

Single Herb Exhibit

- Can enter three single herbs (all edible types) that must be labeled with common and Latin names and in pots 8" diameter maximum, (maximum of three different pots)
- Resource H)-28; 4-H 970-W
- For list of herbs acceptable for State Fair, see State Fair handbook or 4-H 970-W.

Garden Education—One garden education exhibit per county

Anyone can complete Section IV (Garden Education), but members enrolled in Levels C and D of the Garden project SHOULD exhibit one of the following activities in addition to the Produce Exhibit (Section I, II, and III).

Produce Options

- Exhibit four (4) plates containing two cultivars of two different kinds of vegetables in your garden. *For example:* display tomato *Rutgers* and tomato *Roma* on two plates and spinach *Melody* and *America* on two plates. Label the cultivars you exhibit.
- Label and exhibit three unusual vegetables (may or may not be discussed in your 4-H Garden Manual) you grew in your garden this year. If not listed in the vegetable display chart, check with your Extension office. *For example:* spaghetti squash, head lettuce, etc.

Poster Options

1. Make a poster of five commonly found diseases in vegetable gardens, the damage caused by each, and the control options for each.
2. Make a poster of five commonly found vegetable garden insects: beneficial (good guys) and/or injurious (bad guys), benefits or damage caused by each, and the related management practices (how to keep the beneficial, and how to control the injurious insects).
3. Make a poster of a maximum of 10 pests (diseases, insects, weeds, and/or rodents) you found in your garden this year, damage caused, control measures used, and results.
4. Make a poster explaining a computer garden program or mobile application.
5. Make a poster showing a picture story of what you did in your garden this year. *Example:* how you planned, planted, and maintained your garden.
6. Make a poster showing your financial record.
7. Make a poster of pictures showing your experiences in hydroponics.
8. Make a poster explaining various career options working with vegetables/herbs.

9. Make a poster explaining types of pollinators and their importance in vegetable and fruit production.
10. Make a poster that shows the different types of plant parts that are consumed by humans. Be sure to identify the fruit or vegetable and categorize it by root, stem, leaf, or flower.
11. Make a poster that shows different storage methods for vegetables.
12. Make a poster showing how to create a raised bed or container vegetable garden.
13. Make a poster discussing how herbs listed on the last page of 4-H garden Publication 4-H 970-W are used and have been used throughout history. Be sure to include both culinary and medicinal uses as well as other unique uses, if any.

Exhibit Class Guidelines:

Level A (grades 3-4 suggested)

Choose one or more options outlined below. All vegetable and herb exhibits must include common name, Latin name, and variety. Vegetable exhibits entered at state fair will be donated to local food banks and homeless shelters after being judged and not displayed.

Level B (grades 5-6 suggested)

Choose one or more options outlined below. All vegetable and herb exhibits must include common name, Latin name, and variety. Vegetable exhibits entered at state fair will be donated to local food banks and homeless shelters after being judged and not displayed.

Level C (grades 7-9 suggested)

Choose one or more options outlined below. All vegetable and herb exhibits must include common name, Latin name, and variety. Vegetable exhibits entered at state fair will be donated to local food banks and homeless shelters after being judged and not displayed.

Level D (grades 10-12 suggested)

Choose one or more options outlined below. All vegetable and herb exhibits must include common name, Latin name, and variety. Vegetable exhibits entered at state fair will be donated to local food banks and homeless shelters after being judged and not displayed.

Garden Collection Option

Create a 3-plate, 4-plate, or 5-plate collection display of vegetables you have grown and cared for from the single vegetable list. Display each vegetable on a disposable plate. Inclusion of flowers is optional.

Single Vegetable Option

Display from the list below vegetables you have grown and cared for on a disposable plate.

Vegetable	Plated Display Description
Asparagus	Asparagus, 5 spears
Beans	Cowpea, black-eyed pea, southern pea, etc., 10 pods or ½ cup shelled
Beans	Snap, Green or Wax, 10 pods
Beans	Lima-large or small - 10 pods or ½ cup shelled
Beans	Navy, kidney, shell out, etc.-1/2 cup shelled
Beets	Round, flat, and long types, 3
Broccoli	Broccoli, 1 head
Broccoli raab	Broccoli raab, 3 heads
Brussels sprouts	Brussels sprouts, 5 heads
Cabbage	Chinese type (bok choy or pak choy), 1 head
Cabbage	Chinese type (napa cabbage), 1 head
Cabbage	Round, Flat or Pointed type, 1 head
Carrots	Carrots, 3
Cauliflower	Cauliflower, 1 head
Celery	Celery, 1 bunch
Chard	Chard, 10 bundled leaves

Collards	Collards, 10 bundled leaves
Corn	Sweet-yellow, white or bicolor, 3 ears
Cucumbers	Dill, Pickling, 3
Cucumbers	English or hothouse, 1
Cucumbers	Slicing with seeds, 3
Eggplant	Eggplant, 1
Kale	Kale, 10 bundled leaves
Kohlrabi	Kohlrabi, 3
Muskmelon	Muskmelon (cantaloupe), 1
Okra	Okra, 3 pods
Onions	Green, 5 onions in a bunch
Onions	Red, Yellow or White, 3
Parsnip	Parsnips, tops off, 3
Peas	Peas, edible pod such as snow peas ,10 pods
Peas	Peas, unshelled, 10 pods
Peppers	Bell type, 3
Peppers	Chili type, 3
Peppers	Serrano type, 3
Peppers	Banana/Long/Wax/Hungarian type, 3
Peppers	Pimiento type (red), 3
Peppers	Cayenne type, 3
Peppers	Jalapeno type, 3
Peppers	Cherry type, 3
Peppers	New Mexican, long green, Anaheim type, 3
Peppers	Ancho type, 3
Peppers	Tabasco type, 3
Peppers	Habanero type, 3
Potato	Potatoes, any color, 3
Pumpkin	Pumpkin, (other), 1
Pumpkin	Table, Canning, or Ornamental, 1
Radishes	Radishes, 5
Rhubarb	Rhubarb, 3 stalks bundled
Rutabaga	Rutabaga, 3
Spinach	Spinach, 10 bundled leaves
Squash	Banana, or other large winter squash type, 1
Squash	Buttercups, Turbans, 1
Squash	Butternut, 1
Squash	Cushaw, 1
Squash	Hubbards – blue, green or golden, 1
Squash	Scallops/Patty Pans, 1
Squash	Straight or crookneck – i.e. summer squash, 1
Squash	Acorn, 1
Squash	Zucchini or cocozelle, 1
Sweet Potato	Sweet potatoes, 3
Tomatillos	Tomatillos, 3
Turnips	Turnips, 3
Watermelon	Watermelon, 1

Herb Option

Display from the list below a single herb plant you have grown and cared for in an appropriate size pot that has a saucer bottom.

Herb Name and Description
Basil (<i>Ocimum basilicum</i>) "all edible types"
Catnip (<i>Nepeta cataria</i>) "all edible types"
Chamomile (<i>Chamaemelum nobile</i>) "all edible types"
Chives (<i>Allium schoenoprasum</i>) "all edible types"
Coriander or Cilantro (<i>Coriandrum sativum</i>) "all edible types"
Dill (<i>Anethum graveolens</i>)
French tarragon (<i>Artemisia dracunculus</i>)
Lavender (<i>Lavendula</i> sp.) "all edible types"
Mint (<i>Mentha</i> sp.) "all edible types"
Oregano (<i>Origanum vulgare</i>)
Parsley (<i>Petroselinum crispum</i>) "all edible types"
Rosemary (<i>Rosemarinus officinalis</i>)
Sage (<i>Salvia officinalis</i>)
Sweet Marjoram (<i>Origanum majorana</i>)
Thyme (<i>Thymus vulgaris</i>) "all edible types"

Potato Tray Option

Display from the list below approximately 30 potatoes you have grown and cared for in a 12 ½" x18" tray. A tray will be provided when checking-in potato exhibits at state fair.

Potato Description
Red (Norland, Triumph), etc.
Russett (Haig, Norgold, Superior), etc.
White, long type (Kennebec), etc.
White, oval type (Irish Cobbler), etc.
White, round type (Katahdin), etc.
Other (yellow, blue, etc.)

Tomato Plate Option

Display from the list below tomatoes you have grown and cared for on a disposable plate.

Tomato Description
Pink or purple, 3
Red (for canning), 3
Red (for market), 3
Roma or paste type, 3
Intermediate type, 10
Small Cherry or Pear, 10
Yellow or orange, 3

Educational Exhibit Option

Create an educational poster, notebook or display about any manual activity or on any gardening topic of choice that is age/grade appropriate. Youth can also design and complete an independent study activity.

GENEALOGY

5 State Fair exhibits—one from each division to the State Fair

- Division 1
- Division 2
- Division 3
- Division 4
- Advanced Division

Exhibit Guidelines:

- Genealogy Record Sheet
- Appropriate forms base on division—available online at:
<https://extension.purdue.edu/4h/Pages/project.aspx?proj=42>

Manual:

- Tracing My Family Tree (Indiana 4-H Genealogy Resource Guide)

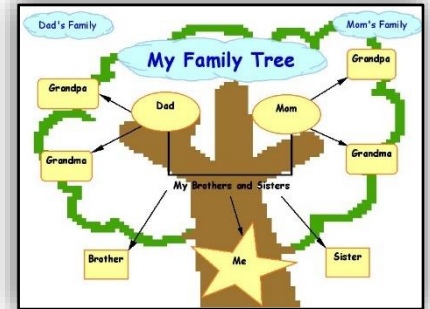

Forms for this project are found on the Indiana 4-H Website:

<https://extension.purdue.edu/4-H/projects/4-h-project-genealogy.html>

The Genealogy project information should appear. This project is organized into divisions and not grades for a youth cannot start in Division 3 without first completing Division 1 and Division 2. This is a project that builds on the previous division information in order to be successful in building your family tree. If you are using a genealogical commercial software program, you may need to type in or hand write in information required by the Indiana 4-H genealogy project. See 4-H forms on the 4-H website linked above.

The exhibit will consist of no more than four (4) notebooks for Division 1-4 and first year Advanced Division. (If a notebook requires additional space, label it as notebook x, continued.) Those notebooks are:

- Book #1 – Appropriate size notebook or binder, contains introduction sheet, pedigree charts and family group sheets
- Book #2 – Appropriate size notebook or binder, contains additional information worksheets and diary of work
- Book #3 – Appropriate size notebook or binder, contains supporting documents, pictures, etc.
- Book #4 – Appropriate size notebook or binder, contains Advanced Division options only (Begin using this notebook in first year of the advanced division or the fifth year of project enrollment.)
- Another notebook should be maintained and kept in a secure place at home to keep original personal and legal documents as well as previously exhibited work.

Note – Youth may consolidate information in order to have fewer notebooks. In this case indicate on the cover the notebook numbers included and use dividers to separate information by notebook number as well as contents as indicated below.

Notebooks should be tabbed and in the following order:

- Book #1 - Introductory Page; Pedigree Charts; Family Group Sheets
- Book #2 - Additional Information Worksheets; Diary of Your Work
- Book #3 - Any Other Documents (label with ancestor numbers on tab)
- Book #4 – Advanced Division Options (label each tab separately with the specific option); Diary of Your Work (this will be a second diary describing work done for each advanced division option)

Pedigree Charts, Family Group Sheets, Additional Information Worksheets, and Diary Sheets are to be placed in the notebook back-to-back in sheet protectors to save space, reduce the information being damaged, and reduce the number of sheet protectors required.

So the notebook exhibit can be displayed to the public and to minimize the potential of identity theft, original legal documents are **NOT** to be included in the exhibit notebook. Instead, a photocopy of any legal document is to be included in the notebook and all identifiable information (like social security numbers) except for names is to be completely marked out. Original legal documents are to be kept in a secure location by the 4-H member and his/her family. All posters, notebooks, and display boards must include a reference list indicating where information was obtained, giving credit to the original author, to complete the 4-H members exhibit. This reference list should/might include web

site links, people and professionals interviewed, books, magazines, etc. Reference notations are to be made in the "source" column of the Family Group Sheet and on each document.

If information on a family member is unknown, an additional information worksheet for each required ancestor is still required. Write "unknown" or "NIA" (no information available) in PENCIL for each sheet of unknown ancestors or list several ancestors on a page and insert page in proper numerical order.

After exhibiting the 1st year of the ADVANCED Division, only the Advanced Division notebook (Book #4) with ALL OPTIONS (no pedigree charts, no family group sheets, no additional information sheets, no documents from Divisions 1-5) needs to be exhibited each year the genealogy project continues.

Suggested Genealogy Supply List:

- Four 3" D-ring notebooks (Book #1, #3, #4 will be exhibited and the fourth 3" D-ring notebook to maintain documents at home and NOT exhibited.)
- One 2" D-ring notebook (Book #2)
- Computer or legible printing/handwriting (be consistent with method used)
- #2 lead pencil with soft eraser
- Black ink pen
- Yellow highlighter
- Notebook tabs AND acid free dividers (several tabs will be needed, be consistent with style used, should not appear past edge of notebook)
- Fine point permanent Black marker
- Acid free and non-glare sheet protectors
- Acid free paper
- Acid free glue stick
- Acid free satin Scotch tape
- Scissors
- Correction tape
- Lots of creativity to make the exhibit your own while still following the exhibit guidelines.

Judges evaluating exhibits should recognize individual differences and creativity therefore using information in this document as a guide rather than a requirement.

Division 1 (1st year in project suggested)

1. Exhibit notebook that includes the following:

- **Book #1**
 - An Introduction page with a recent photograph of yourself.
 - Completed three-generation pedigree chart. This includes you, your parents, and your grandparents, ancestors #1 through #7. Put all surnames in capital letters and all dates in military form (12 July 1974). Give each person a number, as described in the "Recording the Information" section of the Indiana 4-H Genealogy Resource Guide 4-H 748. **You must use the pedigree charts listed at the www.extension.purdue.edu/4h, 4-H 748Pc-W or 4-H 748Pbw-W or the commercial software forms, but not the old "packet" pedigree charts.**
 - A Family Group Sheet for your parents and each pair of grandparents. Sources of information **MUST** be filled in on family group sheets (see section "Recording the Information").
- **Book #2** (Ancestors 1-7 information)
 - Four (4) "Additional Information Worksheets": one (1)
 - for you, the 4-H member
 - one (1) for your parents
 - one (1) for each set of grandparents (total = two worksheets)
 - A diary of your work
- **Book #3** (Ancestors 1-7 information)
 - Any documents or pictures pertaining to these three generations. Documents must be labeled with ancestor name and ancestor number. Pictures need to be labeled with ancestor name, plus names of all known people, place and date picture was taken, as well as ancestor numbers.

Division 2 (2nd year in project suggested)

- Exhibit notebook that includes the following:
 - **Book #1**
 - Four-generation pedigree chart. This would include you, your parents, grandparents, and great-grandparents, ancestors #1 through #15. **You must use the pedigree charts listed at www.extension.purdue.edu/4h, 4-H 748Pc-W or 4-H 748Pbw-W** or the commercial software forms, but not the old "packet" pedigree charts
 - A Family Group Sheet for each pair of great-grandparents. Sources of information filled in on family group sheets (see section "Recording the Information" in the Indiana 4-H Genealogy Resource Guide 4-H 748).
 - **Book #2** (Ancestors 8-15 information)
 - An additional information worksheet for each set of great grandparents.
 - A diary of your work
 - **Book #3** (Ancestors 8-15 information)
 - Any photographs taken of tombstones of your ancestors and their children. Please document location of tombstone(s) and label with ancestor name, ancestor number, and date photo was taken. Rubbings are acceptable in lieu of photographs.
 - Any other documents or pictures pertaining to these generations, correctly labeled.

Exhibit Book #1, Book #2, and Book #3. Books 2 and 3 should only include Division 2 ancestors 8-15 and related information.

Division 3 (3rd year in project suggested)

- Exhibit notebook that includes the following:
 - **Book #1**
 - Five-generation pedigree chart, ancestors #1 through #31. Computer programs do not generally print chart numbers, so if you are using a computer program, make sure you have the correct number of ancestors. If an ancestor is UNKNOWN, please indicate as UNKNOWN. **You must use the pedigree charts listed at www.extension.purdue.edu/4h, 4-H 748Pc-W or 4-H 748Pbw-W**, or the commercial software forms, but not the old "packet" pedigree charts
 - Additional Family Group Sheets for generation five (5). Sources of information must be filled in on family group sheets (see section "Recording the Information" in Indiana 4-H Genealogy Resource Guide 4-H 748.).
 - **Book #2** (Ancestors 16-31 information)
 - Additional information worksheets
 - A diary of your work
 - **Book #3** (Ancestors 16-31 information)
 - Write an autobiography, the story of your life. Include pictures, relevant dates, and important events. OR, write an essay about what your hopes and dreams are for the future, or about life goals you hope to attain.
 - Any documents or pictures pertaining to these generations, correctly labeled.

Exhibit Book #1, Book #2, and Book #3. Books 2 and 3 should only include Division 3 ancestors 16- 31 and related information.

Division 4 (4th year in project suggested)

- Exhibit a notebook(s) that includes the following:
 - **Book #1**
 - Six-generation pedigree charts, ancestors #1 through #63. Computer programs do not generally print chart numbers, so if you are using a computer program, make sure you have the correct number of ancestors. **You must use the pedigree charts listed at www.extension.purdue.edu/4h, 4-H 748Pc-W or 4-H 748Pbw-W**, or the commercial software forms, but not the old "packet" pedigree charts
 - Additional Family Group Sheets for generation six (6). Sources of information must be filled in on family group sheets (see section "Recording the Information").

- **Book #2** (Ancestors 32-63 information)
 - Additional information worksheets
 - A diary of your work
- **Book #3** (Ancestors 32-63 information)
 - A copy of a photograph or a story of a sixth-generation ancestor. Include information about the date when the photograph was taken, how or where you found it and what's happening in it or why it was taken. If this is unavailable, write a story about the historical period during which your sixth generation ancestor was living.
 - Any documents or pictures pertaining to these generations, correctly labeled.

Exhibit Book #1, Book #2, and Book #3. Books 2 and 3 should only include Division 4 ancestors 32- 63 and related information.

Advanced (5th year and above in project suggested)

- Exhibit notebook that includes the following:
 - **Book #1**
 - Seventh and eighth-generation pedigree charts, ancestors #64 through #255. If ancestry is unknown, please indicate as Unknown. Computer programs do not generally print chart numbers, so if you are using a computer program, make sure you have the correct number of ancestors.
 - Your family group sheet for generations seven and eight.
 - Sources of information filled in on family group sheets (see section "Recording the Information" in the Indiana 4-H Genealogy Resource Guide, 4-H 748).
 - **Book #2** (Ancestors 64-255 information)
 - Additional Information worksheets
 - Diary of your work
 - **Book #3** (Ancestors 64-255 information)
 - Any documents or pictures pertaining to these generations; correctly labeled.
 - **Book #4**
 - One new advanced level option (see below). Advanced division exhibitors must include ALL options submitted in prior years, with each option labeled with the year completed.

Pedigree charts are available on the Indiana 4-H Web site for your additional genealogy research. EACH YEAR FOLLOWING, continue to add ancestors to your pedigree charts. In addition, choose one of the following options that has not been completed previously. Please identify, by letter, the option that you are completing (for example: Advanced Division, Year 1, Option A; Advanced Division, Year 2, Option C; etc.)

Advanced Division Year 2 and beyond – Exhibit Book #4 that contains advanced division options and a second diary of work. If additional ancestry information was found in the seventh and eighth generation, exhibit Book 1 noting ancestors completed this year along with Books 2 and 3 demonstrating this year's work.

EXPLAIN the information received as to how it relates to you and your ancestors. Copies of documents obtained in previous divisions are acceptable and should be utilized in the option chosen if needed.

- A. A migration map of your eight-generation ancestors. You should have at least one map per family line with charts or explanations of the migrations.
- B. A timeline historical report of a family line. Show how this family fits into history. Document your report as well as possible with dates, records, places or maps, pictures, etc. Be sure to include proper labels and sources.
- C. A census history of a family line. Census abstract forms can be found on several websites. Download forms to abstract the census. Your notebook should contain copies of the census and the completed abstract form for each census.
- D. A history of your family's religious background for any family line or lines. Include a brief history of the denomination. Include baptism, confirmation or profession of faith and membership records. Also include information or history of the congregations involved. Be sure to include proper labels and sources.
- E. A history of your family's military service for a family line. Include supporting documents when possible. These documents could include military records, (muster rolls, discharge papers, etc.),

pension records, and bounty land records, as well as maps and pictures. Be sure to include proper labels and sources.

- F. A research paper on a famous ancestor. Prove your relationship to this person with documentation. Try to include pictures and anecdotes to enhance your paper.
- G. Complete a family line or lines back as many generations as possible beyond eight generations (ancestors 256 and beyond). Include pictures, maps and documents. Be sure to include proper labels and sources.
- H. A timeline historical report of another family line not previously completed. Document as well as possible as in Option B. You need to state at the beginning that this is a second family historical report on such ancestor.
- I. A history of your family's military service for a family line not previously completed. Include supporting documents as in Option E. You need to state at the beginning that this is a second family military history report on such ancestor.
- J. Family DNA history. (This can be a very expensive option) Please include charts and explanations. i.e. use pie charts, ethnicity estimates, approximate percentage regionally, number of countries searched, genetic percentage, family tree, graphs, etc.
- K. Any other genealogy related activity of choice.

Indiana Historical Society Suggested Genealogy Research Resources

- [Cyndi's List](#) is also a great website to explore when starting out in Genealogy, whether specific to Indiana or not. It's a pretty extensive website. Just jump on and explore.
- **Family Search**
 - Home page: <https://familysearch.org/>
 - Record Search: <https://familysearch.org/search>
 - Wiki: https://familysearch.org/wiki/en/Main_Page - If you're newer to genealogy, definitely look through the Wiki for the location you're going to be researching in. The Step by Step for that state can be super helpful with dates for Vital Record releases and many other tips and tricks.
- **Ancestry.com**
 - Home page: <https://www.ancestry.com/> - This is to sign up for a subscription.
 - Accessing the Library Edition of Ancestry.com has to be at a location that pays for that type of subscription. Check out if your local public library has access, many do. You can look them up online or call to ask if they offer that service or any other genealogy database access. You also have to sign on to their computers to use that service. You can travel with your devices, like laptop or tablet, just know your searching has to be done on their computers. It might be a good idea to travel with a flash drive to save those records you find so you can easily add them to your device and digital records.
- **Indiana State Library**
 - Home page: <http://www.in.gov/library/>
 - Genealogy page: <http://www.in.gov/library/genealogy.htm>
 - Collections & Services page: <http://www.in.gov/library/2353.htm>
- **Indiana State Archives**
 - Home page: <http://www.in.gov/iara/>
 - Records and indices are kept in different locations on the website. Spend some time on the website looking at what is available. If you're have trouble finding it you can call the office and they can guide you through.
- **Indiana Historical Society**
 - Home page: <http://www.indianahistory.org/>
 - Family History Research page: <http://www.indianahistory.org/our-services/family-history/family-history-research#.WQknktorKUK>
 - Family History page: <http://www.indianahistory.org/our-services/family-history#.WQkm7torKUK>
 - On this page you'll see the type of Family History publications we offer, a link for the additional workshops and lectures that I have coming up to learn more about how to do your genealogy research.
 - **Atlas of Historical County Boundaries from The Newberry Library:** <http://publications.newberry.org/ahcbp/index.html> This site has some cool animations for each state and nation.

GEOLOGY

State Fair—3 per county; 1 per level. Geology involves studying the earth's crust, its layers, and their history. Youth learn to identify Indiana rocks, minerals, and fossils.

Judging:

- Geology Record Sheet

Manual:

- 4-H Geology, Level 1
- 4-H Geology, Level 2
- 4-H Geology, Level 3

Additional Materials Available:

- Let's Look at Rocks: Collecting and Identifying Rocks in Indiana



Exhibit Guidelines

All posters, notebooks, and display boards must include a reference list indicating where information was obtained, giving credit to the original author, to complete the 4-H member's exhibit. This reference list should/might include web site links, people and professionals interviewed, books, magazines, etc. It is recommended this reference list be attached to the back of a poster or display board, be the last page of a notebook, or included as part of the display visible to the public. A judge is not to discredit an exhibit for the way references are listed.

Posters are to be 22"x28" and displayed horizontally and placed in a clear plastic sleeve or covered with clear plastic to protect contents. Display boards should be designed to sit on a table using no more than 36" of tabletop space. Space should be left in the lower right-hand corner to place an exhibit tag provided by Purdue Extension staff.

Specimens may also be displayed in a 24"x 18"x 3" collection box, displayed horizontally.

You may purchase your specimens and may display rocks, fossils, and minerals. If you purchase a specimen, indicate when and where you purchased it and the location where you would expect to find the specimen. If you collect a specimen, indicate the county and township where you found it.

- **Posters and display boxes** will be exhibited "standing up" at the Indiana State Fair. Therefore, you need to mount your specimens securely. Subject matter experts suggest the following methods: soaking ½ cotton ball in Elmer's glue, hot glue, or clear tub sealant. Place the cotton ball in your box and put your rock (or fossil or mineral) on the cotton ball and let sit. It will take 1-2 weeks for Elmer's glue to fully harden.
- Specimens mounted with Elmer's glue can be removed by soaking the cotton ball in water. Glue remaining on the rock may be brushed off with an old, damp toothbrush.
- When exhibiting rocks show a fresh surface (recently cracked or broken surface) to help judges identify the rock.
- **Labels** - Include the specific geographical location where you would expect to find any specimens as well as where you actually acquired it (found, purchased, etc.).
- Do not identify your specimens any further than phylum and class. There is one exception to this for fossils which are identified to phylum OR class. Class should only be used for fossils of mollusks, backboneed animals, and arthropods.
- Judges evaluating exhibits should recognize individual differences and creativity, therefore using information in this document as a guide rather than a requirement.

Beginner—Grades 3, 4, & 5

Exhibit: Create an educational poster, notebook or display about any manual activity or on any geology topic of choice that is age/grade appropriate. Below are some ideas from previous years:

- The Rock Cycle (Activity 2)—Explain the rock cycle using both words and pictures.
- Rock Types (Activities 2-4)—Display rocks from the three major types: igneous, sedimentary, and metamorphic. Examples of each include:
 - Igneous—granite, basalt, gabbro
 - Sedimentary—limestone, dolomite, shale, chert, gypsum
 - Metamorphic—quartzite, schist, basalt, granite
- How Rocks Change (Activity 4)—Color and display the picture in your book or draw and color your own on your poster. Briefly describe the earth processes that are shown.
- Rock Artwork (Activity 12)—Display your rock artwork and the story that you created.
- Collections (Activity 11)—Display and identify 8 rocks.
- Making Crystal Models (Activities 14 & 15)—Display the crystal forms characteristic of most minerals (cubic, tetragonal, hexagonal, orthorhombic, monoclinic, triclinic) in a display box with their name and mineral with this form. You may color, paint, or use markers on your crystal models.
- Molds and Casts (Activities 16 & 17)—Display three molds and/or casts in a display box. Describe the steps that you followed to create a mold or cast.

Intermediate—Grades 6, 7, & 8

Exhibit: Create an educational poster, notebook or display about any manual activity or on any geology topic of choice that is age/grade appropriate, or collection of 8-16 minerals and/or fossils. Below are some ideas from previous years:

- Rocks with Different Textures—Identify and display six rocks with three very different textures (two rocks of each general type). Include three grades of sandpaper and show how the differences in sandpaper are similar to the differences in rock texture.
- Indiana limestone—Show and label pictures or photographs of ten buildings, sculptures, or monuments made from Indiana limestone.
- Mineral Properties and Tests—Explain the characteristics: crystal form, cleavage, hardness, appearance, and streak. Explain tests used in identifying specimens. Examples you might include are streak, aid, hardness, chemical analysis, and specific gravity.
- How We Use Minerals—Show 10 common products that contain minerals. Explain the minerals that are contained in these products and the characteristic that makes them useful.
- Geologic Time—Create a display to show the major geologic eras. Indicate the names, specific features, and approximate length of each.
- Indiana’s Glaciers—Show the extent of Indiana’s main three glaciers.
- Indiana Geology—Exhibit a map or sketch of Indiana showing at least ten sites with interesting geological formations.
- Field Trip—Describe a geology field trip that you took. Describe where you went and what you learned. Include photographs (if possible) or sketch what you saw.
- Collections—Display and identify one of the following: 8-16 minerals, fossils, or 4-8 of each (half minerals and half fossils). You may exhibit a new collection in subsequent years but not one you have already exhibited.

Advanced—Grades 9, 10, 11, & 12

Exhibit: Create an educational poster, notebook or display about any manual activity or on any geology topic of choice that is age/grade appropriate, or collection of 15-25 minerals and/or fossils and/or jewel stones. Youth can also design and complete an independent study activity. Below are some ideas from previous years:

- Geology Research—Prepare a display to teach others about the topic you studied. Include an appropriate title, abstract (brief description of your topic), and photographs, drawings, charts, or graphs that help explain your topic. This activity may be repeated if a new topic is chosen in subsequent years.
- Lapidary and Jewelry—Show how stones and minerals are turned into polished stones and jewelry. Show and explain the steps involved.
- Miniatures—Display five miniatures in a display box and explain the benefits of collecting miniatures and how they are prepared.
- Indiana’s State Parks or Forests—Create a matching game of Indiana’s State Parks or Forests and a brief description. This exhibit option should include geological features of the park or forest.
- Indiana, U.S., or World Geology—Teach others about one Indiana, U.S. or World Geology topic.
- Career Exploration—Prepare a display that explains your interview with someone who needs an understanding of geology to do their job.

HEALTH

1 Champion from each level to State Fair

The 4-H Health project is designed for youth interested in basic first aid and healthy well-being, as well as those interested in pursuing a medical profession career.

- Level A: Grades 3, 4, & 5
- Level B: Grades 6, 7, & 8
- Level C: Grades 9, 10, 11, & 12



Health Manual:

- Beginner--First Aid in Action
- Intermediate--Staying Healthy
- Advanced--Keeping Fit

Exhibit Guidelines:

All posters, notebooks, and display boards must include a reference list indicating where information was obtained, giving credit to the original author, to complete the 4-H member's exhibit. This reference list should/might include web site links, people and professionals interviewed, books, magazines, etc. It is recommended this reference list be attached to the back of a poster or display board, be the last page of a notebook, or included as part of the display visible to the public. A judge is not to discredit an exhibit for the way references are listed.

Posters are to be 22"x28" and displayed horizontally and placed in a clear plastic sleeve or covered with clear plastic to protect contents. Display boards should be designed to sit on a table using no more than 36" of tabletop space. Space should be left in the lower right-hand corner to place an exhibit tag provided by Purdue Extension staff.

Judges evaluating exhibits should recognize individual differences and creativity, therefore using information in this document as a guide rather than a requirement.

Beginner for Grades 3, 4, & 5

- Create an educational poster, notebook or display about any manual activity or on any health topic of choice that is age/grade appropriate.
- Another option is to create a family first aid kit, emergency kit, an emergency kit to take on a hiking, biking, skiing or similar trip, or another similar kit.

Intermediate (grades 6-8 suggested)

- Create an educational poster, notebook or display about any manual activity or on any health topic of choice that is age/grade appropriate.
- Another option is to create a personal nutrition kit to use when doing physical activity like chores, working out at the gym, hiking, biking, skiing, or another similar kit.

Advanced (grades 9-12 suggested)

- Create an educational poster, notebook or display about any manual activity or on any health topic of choice that is age/grade appropriate.
- Another option is to create an activity or guide to help yourself or others become more aware of financial wellness, mental health, disease prevention, or other similar topic that promotes healthy habits.
- Youth can also design and complete an independent study activity.

HOME ENVIRONMENT

State Fair Entries—6 per county; 2 per level

- Level 1 Grades 3, 4, & 5
- Level 2 Grades 6, 7, & 8
- Level 3 Grades 9, 10, 11, & 12

Turn in at judging with your project:

- Home Environment Record Sheet
- 4-H Home Environment Project Exhibit Card



Manuals:

- Home Environment: Color, Texture, Line, and Shape (Level 1)
- Home Environment: Design Decisions Resource Guide—University of Nebraska (for Levels 2 & 3) This one manual is to be used for grades 6-12 as a resource and a reference. Indiana 4-H exhibit options are not listed in this manual. You are referred to the Indiana 4-H Youth Development website: www.four-h.purdue.edu or your local county 4-H handbook for exhibit option details.

Exhibit Guidelines;

All posters, notebooks, and display boards must include a reference list indicating where information was obtained, giving credit to the original author, to complete the 4-H member's exhibit. This reference list should/might include web site links, people and professionals interviewed, books, magazines, etc. It is recommended this reference list be attached to the back of a poster or display board, be the last page of a notebook, or included as part of the display visible to the public. A judge is not to discredit an exhibit for the way references are listed.

Posters are to be 22"x28" and displayed horizontally and placed in a clear plastic sleeve or covered with clear plastic to protect contents. Display boards should be designed to sit on a table using no more than 36" of tabletop space. Space should be left in the lower right-hand corner to place an exhibit tag provided by Purdue Extension staff.

Judges evaluating exhibits should recognize individual differences and creativity, therefore using information in this document as a guide rather than a requirement.

Exhibit Categories:

- **Furniture Item and Notebook:** An actual piece of furniture accompanied by a standard notebook (3-ring binder) explaining the who, what, when, where, why, and how of the chosen project. We suggest including pictures showing where the item will be used. Also, we encourage 4-H members to include pictures of themselves doing the project, but this is not required. Always place your identification information in the notebook and on the furniture.
- **Design Board and Notebook:** Standard 22" x 28" poster, displayed horizontally with a firm backing. Design boards must be covered with plastic to protect and help hold items in place. An identification name tag must be attached in the lower right corner. The notebook is to help explain the who, what, when, where, why, and how of the chosen design. This can be a "before and after project" or "plan in the future" project.
- **Portfolio:** Standard notebook (3-ring binder). If 4-H members choose to do this option more than one year, we suggest that they keep the previous year's materials in the notebook. Place materials for the current year in the front, with the previous year's materials clearly marked or labeled at the back. Always place your identification information in the notebook.

Beginner (Level 1)—Grades 3, 4, & 5

Project Completion:

- Turn in Completed Record Sheet
- Attach your 4-H Home Environment Project Exhibit Card 4-H 1011-D-W

Exhibit Options: Choose one of the following options:

- **Furniture Item and Notebook** – create a wall hanging, storage organizer, a set of 3-5 accessory items or something similar for the home or similar activity.
- **Design Board and Notebook** – color a line drawing from your manual and create three color schemes, color a line drawing from your manual and demonstrate dominant and supportive color, or display a line drawing showing where furniture would be placed in the room or similar activity.
- **Portfolio** – Collect different color schemes, magazines showing different furniture designs, or magazines/photographs of formal vs informal balance, dominant and supportive colors, etc. or similar activity.

Intermediate (Level 2)—Grades 6, 7, & 8

Project Completion:

- Turn in Completed Record Sheet
- Attach your 4-H Home Environment Project Exhibit Card 4-H-1011-D-W

Exhibit Options: Choose one of the following options:

- **Furniture Item and Notebook** – refinish or repurpose a piece or set of furniture, storage unit, or display a collection of 3-5 similar home accessory items, or similar activity.
- **Design Board and Notebook** – create a line drawing for a room in your home showing furniture layout, accessory items and fixtures or similar activity.
- **Portfolio** – display a sample of three different types of wall treatment with explanation of each, three different floor treatments with explanation of each, an energy plan for your home, or similar activity.

Advanced (Level 3)—Grades 9, 10, 11, & 12

Project Completion:

- Turn in Completed Record Sheet
- Attach your 4-H Home Environment Project Exhibit Card 4-H-1011-D-W

Exhibit Options: Choose one of the following options:

- **Furniture Item and Notebook** – refinish or repurpose a piece or set of furniture, storage unit, or display a collection of 3-5 similar home accessory items, or similar activity.
- **Design Board and Notebook** – display a floor plan for any room of your house or the whole house or apartment, or similar activity.
- **Portfolio** –display a sample of three different lighting or window treatments with an explanation of each, interview an interior designer and prepare a report, a home energy saving proposal plan, or similar activity.

HORSEMAN WITHOUT HORSES

No State Fair Exhibit

- Division 1—Grade 3
- Division 2—Grade 4
- Division 3—Grade 5
- Division 4—Grade 6
- Division 5—Grade 7

- Division 6—Grade 8
- Division 7—Grade 9
- Division 8—Grade 10
- Division 9—Grade 11
- Division 10—Grade 12

Manual:

- Fulton County Horseman Without Horses for each division

All Divisions

Project Completion: Turn in completed record sheet

Exhibit: Make a poster about one of the following topics: Use a 22” x 28” poster board with a stiff backing and a clear protective covering. Posters should be oriented horizontally. Leave space on the lower right-hand corner of the poster for a vertical 5½” x 3” project label.

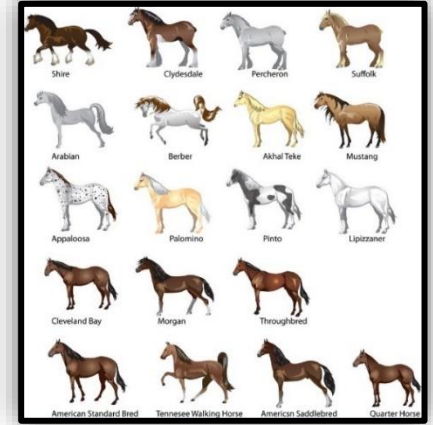

All posters, notebooks and display boards must include a reference list indicating where information was obtained, giving credit to the original author, to complete the 4-H member’s exhibit. This reference list should/might include website links, people and professionals interviewed, books, magazines, etc. It is recommended that this reference list be attached to the back of a poster or display board, be the last page of a notebook, or included as part of the display visible to the public.

Posters are to be 22”x28” and displayed horizontally and placed in a clear plastic sleeve or covered with clear plastic to protect contents. Display boards should be designed to sit on a table using no more than 36” of tabletop space. Space should be left in the lower right-hand corner to place an exhibit tag provided by Purdue Extension staff.

Judges evaluating exhibits should recognize individual differences and creativity, therefore using information in this document as a guide rather than a requirement.

Division 1:	Horse Safety OR Parts of a Horse
Division 2:	Horse Colors and Markings OR Breeds of Light Horses
Division 3:	Horse Grooming OR Hooves and Hoof Care
Division 4:	Horse Terms OR How to Judge a Horse Show
Division 5:	Tack OR Saddles OR Equipment
Division 6:	Gaits OR Showing a Light Horse
Division 7:	Digestive Track OR Feed Nutrients and Feed Types
Division 8:	Careers OR Diseases and Parasites
Division 9:	Breeding and Genetics OR Horse Organizations OR Registering Animals
Division 10:	Care of an Older Horse OR Draft Horses, Clydesdales, etc. OR Pedigrees

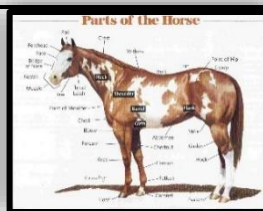

JUNIOR LEADERS



105

No State Fair Exhibit No exhibit

Project Completion:

- Your Record Sheet needs to be turned in at the Community Judging of Community Building Projects

The Junior Leader project allows 4-H members in grades 7-12 the opportunity to provide their Adult 4-H Volunteers with additional assistance in their 4-H Clubs and related activities while serving as mentors and role models to the younger 4-H members by sharing their experiences with them. Many counties offer county-wide opportunities for Jr. Leaders to meet and serve the community.

Junior Leaders become acquainted with 4-H members from the entire county and are invited to attend area and state Junior Leader events. They are also eligible for special trips, awards, and activities.

Eligibility is open to any 4-H member who is in 6th Grade or higher with at least 1 year of 4-H experience. Members are encouraged to attend monthly Junior Leader meetings. To complete the project, they must fill out the Junior Leader record sheet and meet its guidelines.

Junior Leader Membership

In order to be considered as an Ambassador Candidate or to be a Junior Leader Ambassador, a Junior leader **MUST**:

- Pay \$5 dues no later than the April 1 meeting each year.
- Work at least one shift at the Junior Leader Food Booth Fundraiser at the FFA Auction.
- Participate in an average of at least 2 extra Junior Leader County-approved activities per year. The FFA Auction Fundraiser and Completion Trip do not count. Activities that promote leadership and benefit, serve, or help others count. This list includes:
 - Junior Leader Committee meetings
 - Junior Leader Community Service projects
 - Assisting at Project Judging

Junior Leader Ambassadors

- Each year, two Fulton County Jr. Leader Ambassadors will be chosen. They will be expected to assist as needed, with activities and judging events during fair week.
- The Ambassadors will be in their last 2 years of 4-H eligibility, and currently enrolled in the Junior leader project.
- Junior leader points can be earned by attending meetings, participating in activities, serving on committees, completing record books, assisting at the fair, being a camp counselor, etc.

Junior Leader Officer Candidates

To be a Junior Leader Officer Candidate, a 4-H member must be in good standing with the Junior Leader organization. To be in good standing you must have paid your dues and turned in your record sheet on time the year before and have good behavior. Good behavior means:

- A Junior Leader has a positive attitude
- Does not hit or poke or abuse another member
- Respects the United States and the 4-H flags by removing their hat
- Repeats the pledges appropriately and participates.

Although attendance is not required, attendance at meetings and events allows a member to be more knowledgeable about the program and show they care. The following grade guidelines have been established:

- President: Junior or Senior year of high school
- Vice-President: Sophomore, Junior, or Senior year of high school
- Secretary: Freshman, Sophomore, Junior or Senior year of high school
- Treasurer: Freshman, Sophomore, Junior or Senior year of high school
- 4-H Council: Any member

MICRO MINI TRACTOR PULLING (STEM project)

No State Fair

Electric:

- Beginner: Grades 3, 4, & 5
- Intermediate: Grades 6, 7, & 8
- Advanced: Grades 9, 10, 11, & 12

Fuel Powered (Modified):

- Beginner: Grades 3, 4, & 5
- Intermediate: Grades 6, 7, & 8
- Advanced: Grades 9, 10, 11, & 12

Manual:

- Fulton County Micro Mini Tractor Pulling Manual



In Micro Mini Tractor Pulling, youth build, from scratch, a 1/16 scale pulling tractor (farm).

- The 4-H puller and a parent or volunteer will assemble the tractor body and the gear box.
- The tractor body can be any tractor whether it comes off of a shelf at a dealer, out of a sand pile, from the toy box or any other location.
- It needs to be 1/16 scale and have a front axle.
- Project guidelines and information is available at Micro Mini workshops.

OUR AMERICAN HERITAGE

(Listed under Collections and Hobbies)



No State Fair

Revised Guidelines

We are revamping/revising and adding some new ideas to the **Our American Heritage Project**. Several people have volunteered to help with the project. There will be 5 categories from which to choose to do the project.

Categories

- Family Heirloom
 - An **Original Item** should be cleaned and repaired to working condition for exhibit.
- Partner Restoration—Working with another person
 - A **Restored Item** should be refinished, painted, rewired, etc. to be in like—new form. Farm tractors, implements, and other farm machinery, lawn tractors, stationary engines, hand tools, horse drawn and related items are all examples that may be exhibited.
- Repurposed Item—Taking parts and making something decorative or useful
- Farm Implement
- Tractor Restoration

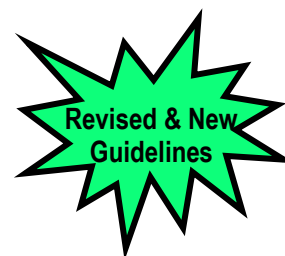

Purpose: To acquaint and encourage the interest of young people in learning about and preserving the history of our American Heritage involving tractors.

Goals: This 4-H project will allow youth to:

- Identify antique items and their uses
- Learn how to restore antiques
- Interact with the “older” generation to learn about uses and to secure help in identification
- Interact with others with a similar interest and to share with others what they have learned.

Needed for Judging

1. Turn in your completed Record Sheet
2. Projects must be accompanied with a notebook giving a complete description of the project that is being exhibited.
 - a. The notebook will account for 25% of the score from the judge.
 - b. The notebook should contain information about your American Heritage project, pictures, and your project record sheet.
 - c. Pictures should have captions that show and explain how you were involved in your project and the work that was completed.
 - d. Before and after pictures would be great and are encouraged.
3. Projects will be evaluated on the notebook’s workmanship, creativity in display, and the 4-H member’s involvement in the overall project.
4. Any work performed on restoration and repair of the project that is not completed by the 4-H member, must be noted in the notebook.
5. Exhibits on display at the county fair will be on display at the 4-H member’s own risk. Valuable items can be taken home after judging, but the notebook **must be left** for display.
6. Depending on the size of the display area at the county fair and the various sizes of items in this project, it will be decided by the project leaders at the fair what extra items can accompany the actual project for display.

All notebooks must include a reference list indicating where information was obtained, giving credit to the original author, to complete the 4-H member’s exhibit. This reference list should/might include website links, people and professionals interviewed, books, magazines, etc. It is recommended that this reference list be the last page of a notebook. Judges evaluating exhibits should recognize individual differences and creativity, therefore using information in this document as a guide rather than a requirement.

PHOTOGRAPHY



State Fair Entries: 8 per county

- 2 beginner per county
- 3 intermediate per county
- 3 advanced per county

Exhibit Guidelines:



- **Posters** are to be 22"x28" and displayed horizontally and placed in a clear plastic sleeve or covered with clear plastic to protect contents.
- **Display boards** should be designed to sit on a table using no more than 36" of tabletop space. Space should be left in the lower right-hand corner to place an exhibit tag provided by Purdue Extension staff.
- All images are to be original images taken by the 4-H member during the current program year. Captions are not recommended.
- **Print board exhibits** are to include 10 photos mounted on a poster as described above, each no larger than 5"x7". Number each print 1-10. Prints may be a mix of digital and/or standard development. Create a title of choice for the print board exhibit. Space should be left in the lower right-hand corner to place an exhibit tag provided by Purdue Extension staff.
- **Salon prints** are to be no larger than 11"x14", mounted on a standard 16"x20" salon mount, and displayed vertically. Salon prints are to be placed in a clear plastic sleeve and captions are not recommended. Space should be left in the lower right-hand corner to place an exhibit tag provided by Purdue Extension staff.
- Images may be taken with a film camera, digital camera, cell phone, or other electronic device.
- Altering of images by any other means besides the device it was taken with is to be entered in the **creative/experimental** category. Creative/experimental exhibits must include the original photo on the back side of the board, a description of how the image was altered, and equipment/software used to alter the image.
- **Sepia tone photographs** (mono chromatic) are to be entered as black and white photos.
- Judges evaluating exhibits should recognize individual differences and creativity, therefore using information in this document as a guide rather than a requirement.

Mounting and Labeling:

- The mounting may be of any color or texture. The pictures are to be neatly and securely mounted. Dry mounting tissue is best.
- Salon mounts are available in most photo and art supply stores. They are available either in plain or with a cutout of the picture area. You may make your own. Matting is not required.
- The standard project identification label (the 5½" x 3" label supplied by the extension office) is to be placed in the exhibit's lower right-hand corner.

Beginner (grades 3-5 suggested)

Exhibit: Turn in your Photography Record Sheet with your project. Choose one or more of the following:

- Black and White Print Board
- Color Print Board
- Black and White Salon Print
- Color Salon Print
- Creative/Experimental Salon Print

Intermediate (grades 6-8 suggested)

Exhibit: Turn in your Photography Record Sheet with your project. Choose one or more of the following:

- Black and White Print Board
- Color Print Board
- Black and White Salon Print
- Color Salon Print
- Creative/Experimental Salon Print

Advanced (grades 9-12 suggested)

Exhibit: Turn in your Photography Record Sheet with your project. Choose one or more of the following:

- Black and White Print Board
- Color Print Board
- Black and White Salon Print
- Color Salon Print
- Creative/Experimental Salon Print



Poultry: POULTRY POSTER

State Fair—One poster from each level will be selected for State Fair

Beginner—Grades 3, 4, & 5

Intermediate—Grades 6, 7, & 8

Advanced—Grades 9, 10, 11, & 12

Manual:

- Poultry 1: Scratching the Surface
- Poultry 2: Testing Your Wings
- Poultry 3: Flocking Together

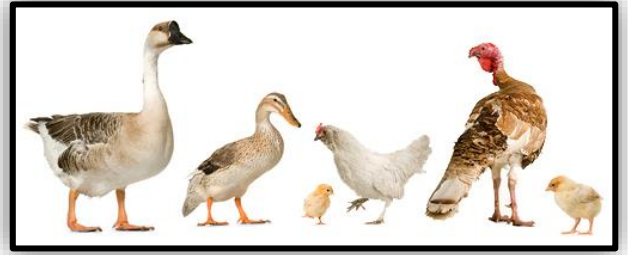

Exhibit Guidelines:

Owning or showing an animal is not required. Members enrolled in any 4-H animal or livestock project can exhibit in this project and are to contact their county 4-H educator to learn if they are to also be enrolled in animal education.

All posters, notebooks, and display boards must include a reference list indicating where information was obtained, giving credit to the original author, to complete the 4-H member's exhibit. This reference list should/might include web site links, people and professionals interviewed, books, magazines, etc. It is recommended this reference list be attached to the back of a poster or display board, be the last page of a notebook, or included as part of the display visible to the public. A judge is not to discredit an exhibit for the way references are listed.

Posters are to be 22"x28" and displayed horizontally and placed in a clear plastic sleeve or covered with clear plastic to protect contents. Display boards should be designed to sit on a table using no more than 36" of tabletop space. Space should be left in the lower right-hand corner to place an exhibit tag provided by Purdue Extension staff.

Judges evaluating exhibits should recognize individual differences and creativity, therefore using information in this document as a guide rather than a requirement.

Beginner—Grades 3-5

Project Completions: Turn in a completed record sheet with your poster.

Exhibit: Create an educational poster, notebook or display about any manual activity or on any specie related topic of choice that is age/grade appropriate. Check with the Purdue Extension office in your county to determine if enrollment is required in the species project you want to learn about. Owning or possessing an animal is not required.

Intermediate—Grades 6, 7, & 8

Project Completions: Turn in a completed record sheet with your poster.

Exhibit: Create an educational poster, notebook or display about any manual activity or on any specie related topic of choice that is age/grade appropriate. Check with the Purdue Extension office in your county to determine if enrollment is required in the species project you want to learn about. Owning or possessing an animal is not required.

Advanced—Grades 9, 10, 11, & 12

Project Completions: Turn in a completed record sheet with your poster.

Exhibit: Create an educational poster, notebook or display about any manual activity or on any specie related topic of choice that is age/grade appropriate. Check with the Purdue Extension office in your county to determine if enrollment is required in the species project you want to learn about. Owning or possessing an animal is not required.

Rabbit: RABBIT POSTER



State Fair—One poster from each level will be selected for State Fair

Beginner—Grades 3, 4, & 5

Intermediate—Grades 6, 7, & 8

Advanced—Grades 9, 10, 11, & 12

Manuals:

- Rabbit 1: What's Hopping?
- Rabbit 2: Making Tracks
- Rabbit 3: All Ears

Exhibit Guidelines:

Owning or showing an animal is not required. Members enrolled in any 4-H animal or livestock project can exhibit in this project and are to contact their county 4-H educator to learn if they are to also be enrolled in animal education.

All posters, notebooks, and display boards must include a reference list indicating where information was obtained, giving credit to the original author, to complete the 4-H member's exhibit. This reference list should/might include web site links, people and professionals interviewed, books, magazines, etc. It is recommended this reference list be attached to the back of a poster or display board, be the last page of a notebook, or included as part of the display visible to the public. A judge is not to discredit an exhibit for the way references are listed.

Posters are to be 22"x28" and displayed horizontally and placed in a clear plastic sleeve or covered with clear plastic to protect contents. Display boards should be designed to sit on a table using no more than 36" of tabletop space. Space should be left in the lower right-hand corner to place an exhibit tag provided by

Purdue Extension staff.

Judges evaluating exhibits should recognize individual differences and creativity, therefore using information in this document as a guide rather than a requirement.

Beginner—Grades 3-5

Project Completions: Turn in a completed record sheet with your poster.

Exhibit: Create an educational poster, notebook or display about any manual activity or on any specie related topic of choice that is age/grade appropriate. Check with the Purdue Extension office in your county to determine if enrollment is required in the species project you want to learn about. Owning or possessing an animal is not required.

Intermediate—Grades 6, 7, & 8

Project Completions: Turn in a completed record sheet with your poster.

Exhibit: Create an educational poster, notebook or display about any manual activity or on any specie related topic of choice that is age/grade appropriate. Check with the Purdue Extension office in your county to determine if enrollment is required in the species project you want to learn about. Owning or possessing an animal is not required.

Advanced—Grades 9, 10, 11, & 12

Project Completions: Turn in a completed record sheet with your poster.

Exhibit: Create an educational poster, notebook or display about any manual activity or on any specie related topic of choice that is age/grade appropriate. Check with the Purdue Extension office in your county to determine if enrollment is required in the species project you want to learn about. Owning or possessing an animal is not required.

SCRAPBOOKING

(Listed under Collections and Hobbies)

No State Fair exhibit

- Level A—Grades 3, & 4
- Level B—Grades 5, & 6
- Level C—Grades 7, 8, & 9
- Level D—Grades 10, 11, & 12

Manual:

- Fulton County 4-H Scrapbook Project



Level A—Grades 3 & 4

Project Completion: Turn in the completed Scrapbook Record Sheet at judging to finish the project.

Exhibit: Complete and Exhibit 4 pages.

- Attach the 4-H label with yarn to the inside of the scrapbook so that it can hang over the front of your scrapbook.
- **Include the skills card with 4 different skills or techniques marked.**
- The 4 different skills or techniques could all be on one page or on more than one page. The Skills and Techniques Card can be found at the end of the manual.
- Include a page indicating the pages to be judged. Enter different pages for judging every year.
- Identify pages that have been judged in previous years by keeping a list in the back of your scrapbook. Either identify page by title (i.e. Basketball or Sleepover '19) or by page number.
- See Numbers 1-12 in the General Scrapbook information section of the manual.

Level B—Grades 5 & 6

Project Completion: Turn in the completed Scrapbook Record Sheet at judging to finish the project.

Exhibit: Complete and Exhibit 6 pages.

- Attach the 4-H label with yarn to the inside of the scrapbook so that it can hang over the front of your scrapbook.
- **Include the skills card with 6 different skills or techniques marked.**
- The 6 different skills or techniques could all be on one page or on more than one page. The Skills and Techniques Card can be found at the end of the manual.
- Include a page indicating the pages to be judged. Enter different pages for judging every year.
- Identify pages that have been judged in previous years by keeping a list in the back of your scrapbook. Either identify page by title (i.e. Basketball or Sleepover '19) or by page number.
- See Numbers 1-12 in the General Scrapbook information section of the manual.

Level C—Grades 7, 8, & 9

Project Completion: Turn in the completed Scrapbook Record Sheet at judging to finish the project.

Exhibit: Complete and Exhibit 8 pages.

- Attach the 4-H label with yarn to the inside of the scrapbook so that it can hang over the front of your scrapbook.
- Include the skills card with 8 different skills or techniques marked.
- **The 8 different skills or techniques could all be on one page or on more than one page.** The Skills and Techniques Card can be found at the end of the manual.
- Include a page indicating the pages to be judged. Enter different pages for judging every year.
- Identify pages that have been judged in previous years by keeping a list in the back of your scrapbook. Either identify page by title (i.e. Basketball or Sleepover '19) or by page number.
- See Numbers 1-12 in the General Scrapbook information section of the manual.

Level D—Grades 10, 11, & 12

Project Completion: Turn in the completed Scrapbook Record Sheet at judging to finish the project.

Exhibit: Complete and Exhibit 10 pages.

- Attach the 4-H label with yarn to the inside of the scrapbook so that it can hang over the front of your scrapbook.
- Include the skills card with 10 different skills or techniques marked.
- **The 10 different skills or techniques** could all be on one page or on more than one page. The Skills and Techniques Card can be found at the end of the manual.
- Include a page indicating the pages to be judged. Enter different pages for judging every year.
- Identify pages that have been judged in previous years by keeping a list in the back of your scrapbook. Either identify page by title (i.e. Basketball or Sleepover '19) or by page number.
- See Numbers 1-12 in the General Scrapbook information section of the manual.



SEWING

Description:

The **Sewing, Wearable** project teaches fabric selection, pattern selection and sewing machine use to construct garments and outfits to be worn by the 4-H member or another person. The **Sewing, Non-Wearable** project teaches fabric selection, pattern selection and sewing machine use to construct items used around the home or other purposes.

Needed for Judging:

- Sewing Record Sheet
- Sewing Skills Card

Manuals:

- Sew Much Fun Level A: Sew Simple
- Sew Much Fun Level B: Sew Smart
- Sew Much Fun Level C: Sew Fine
- Sew Much Fun Level D: And Sew On

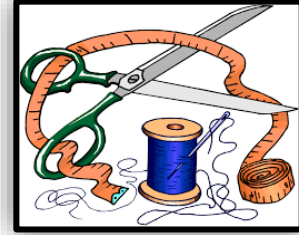

Wearable

New for
2022

State Fair Entries:

5 junior exhibits per county; one per grade level

6 senior exhibits per county; one per category

Exhibit Guidelines:

Older youth enrolled in the 4-H sewing project for the first time may not feel comfortable demonstrating their assigned grade level skills. In this instance the county 4-H youth development educator may, at the request of the 4-H member and parent, assign the member to a lower level grade level to develop fundamental skills.

Provide a completed sewing skills card, 4-H 925c-W, with the exhibit. Skills sheets are for judging purposes only and will not be returned to the exhibitor.

Judges evaluating exhibits should recognize individual differences and creativity, therefore using information in this document as a guide rather than a requirement.

Junior Exhibit Class Guidelines:

Grade 3

- Create one clothing article to be worn by the 4-H member or another person
- Include the Sewing Skills and Techniques card 4-H-925-SC-W that demonstrates at least 2 skills.
- Turn in your Sewing Record Sheet.

Grade 4

- Create one clothing article to be worn by the 4-H member or another person
- Include the Sewing Skills and Techniques card 4-H-925-SC-W that demonstrates at least 2 skills in addition to those learned in the prior grade.
- Turn in your Sewing Record Sheet.

Grade 5

- Create one clothing article or a simple two-piece outfit to be worn by the 4-H member or another person
- Include the Sewing Skills and Techniques card, 4-H-925-SC-W, that demonstrates at least 3 skills in addition to those learned in prior grades.
- Turn in your Sewing Record sheet

Grade 6

- Create two garments that can be worn together by the 4-H member or another person.
- Include the Sewing Skills and Techniques card, 4-H-925-SC-W, that demonstrates at least 4 skills in addition to those learned in prior grades.
- Turn in your Sewing Record sheet.

Grade 7

- Create an outfit that can be worn by the 4-H member or another person.
- Include the Sewing Skills and Techniques card, 4-H-925-SC-W, that demonstrates at least 5 skills in addition to those learned in prior grades.
- Turn in your Sewing Record sheet.

Senior Exhibit Category Class Guidelines

Grades 8-12:

- **Youth may enter an exhibit in one or more categories.**
- Create an outfit from one of the categories defined below that can be worn by the exhibitor or another person
- Include the Sewing Skills and Techniques card, 4-H-925-SC-W, that demonstrates at least 6 skills in addition to those learned in prior grades.
- All senior sewing outfits exhibited in Fashion Revue must be made and worn by the exhibitor.

DEFINITION OF AN OUTFIT: An outfit is a garment or garments that when put together make a complete look - such as one- or two-piece dress, or one- or two-piece pant suit, or a three-piece combination, such as pants, vest, and blouse or shirt.

Informal or Casual Wear:

A complete outfit of 1 or 2 pieces suitable for school, weekend, or casual, informal activities. A complete outfit is defined as a garment or garments that when put together make a complete look--such as one- or two-piece dress, or one- or two-piece pant suit, or a three-piece combination, such as pants, vest, and blouse or shirt.

Dress Up:

This is suitable for special, church, or social occasions that are not considered to be formal. It may be an outfit of one or more pieces with or without its own costume coat or jacket (lined or unlined). This is not an outfit that would be worn to school, weekend, or casual, informal activities.

Free Choice:

A complete outfit comprised of garments that do not fit in the other classifications. A complete outfit is defined as a garment or garments that when put together make a complete look - such as one- or two-piece dress, or one- or two-piece pant suit, or a three-piece combination, such as pants, vest, and blouse or shirt. Individual garment examples include: tennis wear, swim wear, athletic or sportswear, lounge wear, riding habits, historic, dance, theatrical, or international costumes, capes, and unlined coats.

Suit or Coat:

The suit consists of two pieces including a skirt or pants and its own lined jacket. It is not a dress with jacket as in "dress up wear". The coat is a separate lined coat. It will be judged separately as a coat with its own accessories.

Separates:

Consists of three garments that must be worn as a coordinated complete outfit. A complete outfit is defined as a garment or garments that when put together make a complete look-- such as one- or two-piece dress, or one- or two-piece pant suit, or a three-piece combination, such as pants, vest, and blouse or shirt. Each piece should be versatile enough to be worn with other garments.

Formal Wear:

This outfit may be one or more pieces suitable for any formal occasion, such as proms, weddings, and formal evening functions.



State Fair Entries:

10 exhibits per county; one per grade level

Exhibit Guidelines:

Older youth enrolled in the 4-H sewing project for the first time may not feel comfortable demonstrating their assigned grade level skills. In this instance the county 4-H youth development educator may, at the request of the 4-H member and parent, assign the member to a lower level grade level to develop fundamental skills.

Provide a completed sewing skills card, 4-H 925c-W, with the exhibit. Skills sheets are for judging purposes only and will not be returned to the exhibitor.

Judges evaluating exhibits should recognize individual differences and creativity, therefore using information in this document as a guide rather than a requirement.

Grade 3

- Create one non-wearable sewn item.
- Include the Sewing Skills and Techniques card, 4-H-925-SC-W, that demonstrates at least 2 skills learned.
- Turn in Sewing Record Sheet.

Grade 4

- Create one non-wearable sewn item or set of items.
- Include the Sewing Skills and Techniques card, 4-H-925-SC-W, that demonstrates at least 2 skills learned, in addition to those learned in the prior grade.
- Turn in Sewing Record Sheet.

Grade 5

- Create one non-wearable sewn item or set of items.
- Include the Sewing Skills and Techniques card, 4-H-925-SC-W, that demonstrates at least 3 skills learned, in addition to those learned in prior grades.
- Turn in Sewing Record Sheet.

Grade 6

- Create one non-wearable sewn item or set of items.
- Include the Sewing Skills and Techniques card, 4-H-925-SC-W, that demonstrates at least 4 skills learned, in addition to those learned in prior grades.
- Turn in Sewing Record Sheet.

Grade 7

- Create one non-wearable sewn item or set of items.
- Include the Sewing Skills and Techniques card, 4-H-925-SC-W, that demonstrates at least 5 skills learned, in addition to those learned in prior grades.
- Turn in Sewing Record Sheet.

Grades 8, 9, 10, 11, & 12

- Create one non-wearable sewn item or set of items.
- Include the Sewing Skills and Techniques card, 4-H-925-SC-W, that demonstrates at least 6 skills learned, in addition to those learned in prior grades.
- Turn in Sewing Record Sheet.

- Youth and their mentor/volunteer leader/instructor should use this chart as a guide when deciding appropriate skills to incorporate in a sewing wearable or non-wearable article, garment or outfit for exhibit. While this list is a guide, it is not meant to be an all-inclusive list and youth should demonstrate skills they are most comfortable mastering. For example, some youth in a 4th grader might feel comfortable attempting 6th grade level skills, but it is unlikely a 4th grade level exhibitor will be able to successfully master the 10th grade level skills.
- Exhibited items must demonstrate the minimum skill techniques from their given grade level but may also include higher/lower level techniques that have been mastered. Any higher/lower level techniques will not be counted as part of the minimum skills, but nevertheless will be evaluated for quality.
- Youth are encouraged to utilize a number of resources such as web sites, print material, social media, and television shows when learning sewing skills and techniques. Skills learned from these types of resources may be demonstrated provided they are age/grade appropriate.

Grade 3—Demonstrate at least 2 of the following skills:

- Insert elastic or drawstring
- Sew and trim a crotch curve
- Machine topstitch hems
- Use a simple seam finish
- Stitch in the ditch

Grade 4—Demonstrate at least 2 of the following skills:

- Use interfacing
- Staystitch and understitch
- Apply a facing or binding
- Stitch curved seams
- Trim and grade seams
- Work with fiberfill
- Machine topstitch hems

Seam finishes are recommended on all exposed seams.

Grade 5—Demonstrate at least 3 of the following skills:

- Match fabric design
- Gather fabric
- Insert zipper
- Use a drawstring
- Hand-stitch a hem
- Sew a simple sleeve
- Apply purchased trim or ribbons
- Sew patch or inseam pockets
- Use a simple lining
- Do a machine blind hem
- Apply machine topstitching
- Do a machine topstitched hem
- Sew with knit
- Insert elastic
- Apply facings
- Sew buttons
- Apply binding
- Use batting

Seam finishes are recommended on all exposed seams (except knits). Interfacing, understitching, and trimming should be used when appropriate.

Grade 6—Demonstrate at least 4 of the following skills:

- Make darts
- Set in sleeves
- Insert a lapped zipper
- Hand-stitch a hem
- Make buttonholes
- Sew patch pockets
- Apply bindings
- Do a machine topstitched hem
- Sew facings
- Apply ribbings
- Sew a simple collar
- Do a machine blind hem
- Sew with knit
- Match fabric design
- Use fiberfill
- Apply machine appliqué
- Insert piping
- Apply machine topstitching
- Construct with a serger
- Sew inseam pockets

Seam finishes are recommended on all exposed seams (except knits). Interfacing, understitching, and trimming should be used when appropriate.

Grade 7—Demonstrate at least 5 of the following skills:

- Make darts
- Set in sleeves
- Sew facing
- Apply ribbing
- Apply a collar
- Sew on buttons
- Use doll joints
- Apply inseam pockets
- Apply front hip pockets
- Match fabric design
- Apply trims
- Apply machine or hand appliqué
- Apply machine topstitching
- Insert a lapped zipper
- Insert an invisible zipper
- Insert a separating zipper
- Insert a fly front zipper
- Do machine quilting
- Do a hand-stitched hem
- Do a machine topstitched hem
- Do a machine blind hem
- Attach cuffs
- Apply binding
- Sew lining
- Apply ruffles
- Insert piping
- Make buttonholes
- Use fiberfill
- Apply patch pockets
- Use a twin needle
- Apply tucks/pleats
- Construct with a serger
- Apply machine embroidery

Seam finishes are recommended on all exposed seams (except knits). Interfacing, understitching, and trimming should be used when appropriate.

Grades 8, 9, 10, 11, & 12—Demonstrate at least 6 of the following skills:

- Make darts
- Make tucks
- Add lining
- Add facings
- Add plackets
- Add lapels
- Make sleeves
- Add gathers
- Apply trim
- Apply ribbing
- Add a drawstring
- Use shaped seams
- Use fiberfill and/or batting
- Add a waistband
- Add patch pockets
- Add front hip pockets
- Match fabric design
- Make shoulder pads
- Apply machine embroidery
- Coordination of fabric for quilted item
- Do machine or hand quilting
- Apply machine or hand appliqué
- Apply machine topstitching
- Insert an invisible zipper
- Insert a separating zipper
- Insert a fly front zipper
- Insert a lapped zipper
- Insert a hand-picked zipper
- Do a machine topstitched hem
- Do a machine blind hem
- Attach cuffs
- Make pleats
- Insert elastic
- Add boning
- Apply a collar
- Insert piping
- Make a neckband
- Add vents
- Sew buttons
- Add underlining
- Add ruffles
- Sew with knit
- Make button loops
- Do hand beading
- Add inseam pockets
- Add welt pockets
- Use twin needles
- Create bound edges
- Hand/machine beading
- Make a reversable item
- Do a hand-stitched hem
- Make self-covered buttons
- Use specialty threads
- Make self-enclosed seams
- Sew with difficult fabric
- Construct with a serger
- Make machine buttonholes
- Make bound buttonholes
- Piece quilted item
- Other skills not listed above.

Seam finishes are recommended on all exposed seams (except knits). Interfacing, understitching, and trimming should be used when appropriate.

SHOOTING SPORTS



State Fair—3 per county; 1 per level

- Level 1—Grades 3, 4, & 5
- Level 2—Grades 6, 7, & 8
- Level 3—Grades 9, 10, 11, & 12

Needed for Judging:

- Shooting Sports Record Sheet

Exhibit Guidelines:

- All posters, notebooks, and display boards must include a reference list indicating where information was obtained, giving credit to the original author, to complete the 4-H member's exhibit. This reference list should/might include web site links, people and professionals interviewed, books, magazines, etc. It is recommended this reference list be attached to the back of a poster or display board, be the last page of a notebook, or included as part of the display visible to the public. A judge is not to discredit an exhibit for the way references are listed.
- Posters are to be 22"x28" and displayed horizontally and placed in a clear plastic sleeve or covered with clear plastic to protect contents.
- Display boards should be designed to sit on a table using no more than 36" of tabletop space. Space should be left in the lower right-hand corner to place an exhibit tag provided by Purdue Extension staff.
- Live ammunition is not allowed to be exhibited (no powder or primer). Firearms or ready to shoot bows are not allowed to be exhibited. Unstrung bows are permissible.
- An arrow with its arrowhead attached must be displayed in a secure case. An arrowhead without the arrow attached must be displayed in a secure case. An arrow may be displayed unsecured if its arrowhead is removed. Modern broadhead arrows are not allowed to be exhibited.
- Displays involving firearms or bows may be exhibited as a photographic display on a poster or in a notebook following grade level guidelines.
- Handmade items must include information explaining how the item was made and its intended use. Photos are encouraged.
- Some County 4-H programs offer in-person shooting instruction, depending on facilities. Disciplines include archery, rifle, shotgun, muzzleloader and pistol. In-person instruction in any of these disciplines must be led by a 4-H certified instructor. While some counties provide an option to exhibit at the county level, there is no state fair exhibit in these specific disciplines. Contact your county 4-H educator to learn about discipline opportunities in your county.
- Judges evaluating exhibits should recognize individual differences and creativity, therefore using information in this document as a guide rather than a requirement.

Beginner—Grades 3, 4, & 5

Exhibit:

- Turn in your Shooting Sports Record Sheet.
- Create an educational poster, notebook or display about a shooting sports topic of choice that is age/grade appropriate.

Intermediate—Grades 6, 7, & 8

Exhibit:

- Turn in your Shooting Sports Record Sheet.
- Create an educational poster, notebook or display about a shooting sports topic of choice that is age/grade appropriate.
- **OR** Another option is to create an item to be used when developing shooting sports skills.

Advanced—Grades 9, 10, 11, & 12

Exhibit:

- Turn in your Shooting Sports Record Sheet.
- Create an educational poster, notebook or display about a shooting sports topic of choice that is age/grade appropriate.
- **OR** Another option is to create an item to be used when developing shooting sports skills.
- **OR** Youth can also design and complete an independent study activity.

SMALL ENGINES

State Fair—3 exhibits; 1 Champion from each level

Beginner—Grades 3, 4, & 5

Intermediate—Grades 6, 7, & 8

Advanced—Grades 9, 10, 11, & 12

The 4-H Small Engine project creates the education and hands-on opportunity for youth to learn all about engines.

Manuals:

- Small Engines Level 1, Crank It Up
- Small Engines Level 2, Warm It Up
- Small Engines Level 3, Tune It Up



Exhibit Guidelines:

- All posters, notebooks, and display boards must include a reference list indicating where information was obtained, giving credit to the original author, to complete the 4-H member's exhibit. This reference list should/might include web site links, people and professionals interviewed, books, magazines, etc. It is recommended this reference list be attached to the back of a poster or display board, be the last page of a notebook, or included as part of the display visible to the public. A judge is not to discredit an exhibit for the way references are listed.
- Posters are to be 22"x28" and displayed horizontally and placed in a clear plastic sleeve or covered with clear plastic to protect contents.
- Display boards should be designed to sit on a table using no more than 36" of tabletop space. Space should be left in the lower right-hand corner to place an exhibit tag provided by Purdue Extension staff.
- The actual small engine may be displayed if mounted on a stable base. For safety reasons, all fluids (fuel and oil) must be removed before taking the exhibit inside a building. A notebook is to accompany the engine display and include details and pictures of what was done to the engine.
- Judges evaluating exhibits should recognize individual differences and creativity, therefore using information in this document as a guide rather than a requirement.

Beginner—Grades 3, 4, & 5

Exhibit:

- Create an educational poster, notebook or display about any small engine topic of choice that is age/grade appropriate or a rebuilt small engine.
- Turn in your completed Small Engine record sheet.

Intermediate (grades 6-8 suggested)

- Create an educational poster, notebook or display about any small engine topic of choice that is age/grade appropriate or a rebuilt small engine.
- Turn in your completed Small Engine record sheet.
-

Advanced (grades 9-12 suggested)

- Create an educational poster, notebook or display about any small engine topic of choice that is age/grade appropriate or a rebuilt small engine.
- **OR** Youth can also design and complete an independent study activity.
- Turn in your completed Small Engine record sheet.

SOIL AND WATER SCIENCE

State Fair—3 per county; 1 per level

- Beginner Level 1—Grades 3, 4, & 5
- Intermediate Level 2—Grades 6, 7, & 8
- Advanced Level 3—Grades 9, 10, 11, & 12



Manual:

- Soil and Water Science, Level 1 Grades 3-5 (manual or PDF form)
- Soil and Water Science, Level 2 Grades 6-8
- Soil and Water Science, Level 3 Grades 9-12

Exhibit Guidelines:

All posters, notebooks, and display boards must include a reference list indicating where information was obtained, giving credit to the original author, to complete the 4-H member's exhibit. This reference list should/might include web site links, people and professionals interviewed, books, magazines, etc. It is recommended this reference list be attached to the back of a poster or display board, be the last page of a notebook, or included as part of the display visible to the public. A judge is not to discredit an exhibit for the way references are listed.

Posters are to be 22"x28" and displayed horizontally and placed in a clear plastic sleeve or covered with clear plastic to protect contents. Display boards should be designed to sit on a table using no more than 36" of tabletop space. Space should be left in the lower right-hand corner to place an exhibit tag provided by Purdue Extension staff.

Judges evaluating exhibits should recognize individual differences and creativity, therefore using information in this document as a guide rather than a requirement.

Beginner Level 1—Grades 3, 4, & 5

- Turn in completed record sheet to finish the project.
- Create an educational poster, notebook or display about any manual activity or on any soil and water topic of choice that is age/grade appropriate.

Intermediate Level 2—Grades 6, 7, & 8

- Turn in completed record sheet to finish the project.
- Create an educational poster, notebook or display about any manual activity or on any soil and water topic of choice that is age/grade appropriate.

Advanced Level 3—Grades 9, 10, 11, & 12

- Turn in completed record sheet to finish the project.
- Create an educational poster, notebook or display about any manual activity or on any soil and water topic of choice that is age/grade appropriate. Youth can also design and complete an independent study activity.

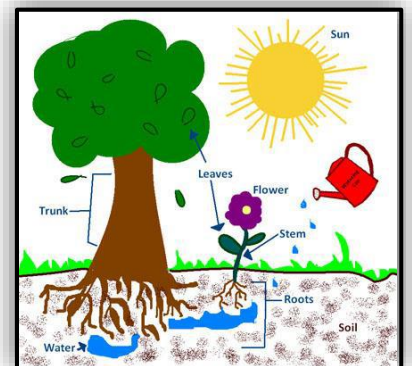

SPORTS (STEM project)



No State Fair Exhibit

- Level 1: Grades 3, 4, & 5
- Level 2: Grades 6, 7, & 8
- Level 3: Grades 9, 10, 11, & 12

Manual:

- Fulton County Sports Manual

All Divisions:

Project Completion: Turn in completed Record Sheet to finish the project.

Exhibit a notebook, poster or scrapbook, showing what you have done or learned in sports. You may repeat a sport area.

- You may choose any sports activity that you would enjoy learning more about.
- For Fair Exhibit, you may make a notebook, poster, or scrapbook showing what you have done or learned in your sports activity.
- You will also need to fill out a Sports Record Sheet included in the manual.
- Sources of Information for this project may be found at the Purdue University Cooperative Extension Service Office, the public library, the Internet, at a sporting goods store, or at school.
- You may enroll in one sports project area each year.
- See the Community Building General Exhibit Guidelines section in your Project Summary Guide for more information about preparing your exhibit.
- Possible Sport Activity Topics from which to choose include:
 - Aerobics
 - Archery
 - Baseball
 - Basketball
 - Bicycling
 - Bowling
 - Camping
 - Cross Country
 - Diving
 - Fishing
 - Football
 - Golf
 - Gymnastics
 - Hockey
 - Ice Skating
 - Rollerblading or Roller Skating
 - Skiing
 - Soccer
 - Softball
 - Swimming
 - Track and Field
 - Trampoline
 - Volleyball
 - Walking or Hiking

Posters:

All posters, notebooks, and display boards must include a reference list indicating where information was obtained, giving credit to the original author, to complete the 4-H member's exhibit. This reference list should/might include web site links, people and professionals interviewed, books, magazines, etc. It is recommended this reference list be attached to the back of a poster or display board, be the last page of a notebook, or included as part of the display visible to the public. A judge is not to discredit an exhibit for the way references are listed.

Posters are to be 22"x28" and displayed horizontally and placed in a clear plastic sleeve or covered with clear plastic to protect contents. Display boards should be designed to sit on a table using no more than 36" of tabletop space. Space should be left in the lower right-hand corner to place an exhibit tag provided by Purdue Extension staff.

Judges evaluating exhibits should recognize individual differences and creativity, therefore using information in this document as a guide rather than a requirement.

SPORTFISHING

State Fair—3 per county; 1 per level

- Beginner Level 1—Grades 3, 4, & 5
- Intermediate Level 2—Grades 6, 7, & 8
- Level 3—Grades 9, 10, 11, & 12



Needed for Judging:

- Sportfishing Record Sheet

Manual:

- Fishing 1: Take the Bait
- Fishing 2: Reel in the Fun
- Fishing 3: Cast into the Future

Exhibit Guidelines:

All posters, notebooks, and display boards must include a reference list indicating where information was obtained, giving credit to the original author, to complete the 4-H member's exhibit. This reference list should/might include web site links, people and professionals interviewed, books, magazines, etc. It is recommended this reference list be attached to the back of a poster or display board, be the last page of a notebook, or included as part of the display visible to the public. A judge is not to discredit an exhibit for the way references are listed.

Posters are to be 22"x28" and displayed horizontally and placed in a clear plastic sleeve or covered with clear plastic to protect contents. Display boards should be designed to sit on a table using no more than 36" of tabletop space. Space should be left in the lower right-hand corner to place an exhibit tag provided by Purdue Extension staff.

Judges evaluating exhibits should recognize individual differences and creativity, therefore using information in this document as a guide rather than a requirement.

Beginner Level 1—Grades 3, 4, & 5

- Turn in completed record sheet to finish the project.
- Create an educational poster, notebook or display about a sportfishing topic of choice that is age/grade appropriate.

Intermediate Level 2—Grades 6, 7, & 8

- Turn in completed record sheet to finish the project.
- Create an educational poster, notebook or display about a sportfishing topic of choice that is age/grade appropriate.
- **OR** another option is to create an item to be used when developing sportfishing skills.

Advanced Level 3—Grades 9, 10, 11, & 12

- Turn in completed record sheet to finish the project.
- Create an educational poster, notebook or display about a sportfishing topic of choice that is age/grade appropriate.
- **OR** another option is to create an item to be used when developing sportfishing skills.
- **OR** youth can also design an complete an independent study activity.

TRACTOR SECTION

Includes:

- Lawn and Garden Tractor Safety and Operator Skills
- Tractor Safety and Operator Skills
- Zero-Turn Mower Safety and Operator Skills

This year, both the Tractor Poster and the Operator Skills are listed together as the same project. You will be able to choose one or the other or both if you wish.

LAWN AND GARDEN TRACTOR SAFETY AND OPERATOR SKILLS

For this project, you may choose to do a poster, notebook, or display AND/OR participate in the operator skills contest. You may choose to do one of them or both of them.

EDUCATION OPTION

State Fair Entries:

- 4 educational exhibits per county; 1 per level

Manuals:

Level A—Starting Up: Getting to Know Your Tractor

Level B—Tractor Operations: Gearing Up for Safety

Level C—Moving Out: Learning About Your Tractor and Farm Machinery

Level D—Learning More: Learning About Agricultural Tractors & Equipment

Exhibit Guidelines:

All posters, notebooks, and display boards must include a reference list indicating where information was obtained, giving credit to the original author, to complete the 4-H member's exhibit. This reference list should/might include web site links, people and professionals interviewed, books, magazines, etc. It is recommended this reference list be attached to the back of a poster or display board, be the last page of a notebook, or included as part of the display visible to the public. A judge is not to discredit an exhibit for the way references are listed.

Posters are to be 22"x28" and displayed horizontally and placed in a clear plastic sleeve or covered with clear plastic to protect contents. Display boards should be designed to sit on a table using no more than 36" of tabletop space. Space should be left in the lower right-hand corner to place an exhibit tag provided by Purdue Extension staff.

Youth may exhibit in the operator skills option, educational exhibit option or both. Youth choosing to exhibit in the lawn and garden tractor, tractor, or zero-turn mower operator skills driving option must select one, but may be enrolled in all three projects.

Judges evaluating exhibits should recognize individual differences and creativity, therefore using information in this document as a guide rather than a requirement.

Level A—Grades 3, & 4

- Create an educational poster, notebook or display about any manual activity or on any lawn and garden tractor safety, maintenance, operating system or operation topic of choice that is age/grade appropriate.
- Turn in record sheet.

Level B—Grades 5 & 6

- Create an educational poster, notebook or display about any manual activity or on any lawn and garden tractor safety, maintenance, operating system or operation topic of choice that is age/grade appropriate.
- Turn in record sheet.

Level C—Grades 7, 8, & 9

- Create an educational poster, notebook or display about any manual activity or on any lawn and garden tractor safety, maintenance, operating system or operation topic of choice that is age/grade appropriate.
- Turn in record sheet.

Level D—Grades 10, 11, & 12

- Create an educational poster, notebook or display about any manual activity or on any lawn and garden tractor safety, maintenance, operating system or operation topic of choice that is age/grade appropriate.
- **OR** youth can also design and complete an independent study activity.
- Turn in record sheet.

State Fair Entries

- 3 junior and 3 senior driving contestants will qualify at the **county** level to compete at the area level contest.
- 3 junior and 3 senior driving contestants will qualify at the **area** level to compete at the state contest.

Materials Available:

- Tests and Parts identification are available on the Internet at:
<https://extension.purdue.edu/4-H/projects/4-h-project-tractor-and-mower-safety-and-operator-skills.html>

Junior Division—Grades 3, 4, 5, 6, & 7

Youth will demonstrate their operation skills by driving a lawn and garden tractor through an obstacle course as outlined in 4-H 84, Conducting 4-H Operator Safety Contests.

<https://extension.purdue.edu/4-H/projects/4-h-project-tractor-and-mower-safety-and-operator-skills.html>

Senior Division—Grades 8, 9, 10, 11, & 12

Youth will demonstrate their operation skills by driving a lawn and garden tractor through an obstacle course as outlined in 4-H 84, Conducting 4-H Operator Safety Contests.

https://extension.purdue.edu/4h/Documents/4-H_84_Conducting_Petroleum_Power_contests.pdf

1. All participants will be scored on written quiz, parts identification, tractor operation on the course, safety while at the contest and time.
2. Any stake knocked over by the contestants (with any part of the tractor or wagon) will be replaced and the contestant must attempt the obstacle until satisfactorily completed or until time expires.
3. The written quiz will consist of 25 multiple choice questions, with 20 points added for each question answered incorrectly or omitted.
4. The parts identification quiz will consist of 25 parts. 20 points will be added to the contestant's score for each part incorrectly identified. **Note:** Pictures will be used for this component.
5. **Junior division** questions will be taken from supplement #1, **Questions and Answers for Junior division Written Test**, dated 2003. **Senior division** questions will be taken from supplement #2 **Questions and Answers for Senior division**, dated 2003, **PLUS**, supplement #1 mentioned above.
6. The driving event will be timed and will be scored on the basis of one (1) penalty point for each second. However, other penalty points for safety violations, hit markers, etc., will be so severe that the importance of speed will be minimized.
7. Terms and conditions will be as outlined in 4-H 84 **Conducting 4-H Petroleum Power Operators Contest**.

TRACTOR SAFETY AND OPERATOR SKILLS

For this project, you may choose to do a poster, notebook, or display AND/OR participate in the operator skills contest. You may choose to do one of them or both of them.

EDUCATION OPTION

State Fair Entries:

- 4 educational exhibits per county; 1 per level

Manuals:

Level A—Starting Up: Getting to Know Your Tractor

Level B—Tractor Operations: Gearing Up for Safety

Level C—Moving Out: Learning About Your Tractor and Farm Machinery

Level D—Learning More: Learning About Agricultural Tractors & Equipment

Exhibit Guidelines:

All posters, notebooks, and display boards must include a reference list indicating where information was obtained, giving credit to the original author, to complete the 4-H member's exhibit. This reference list should/might include web site links, people and professionals interviewed, books, magazines, etc. It is recommended this reference list be attached to the back of a poster or display board, be the last page of a notebook, or included as part of the display visible to the public. A judge is not to discredit an exhibit for the way references are listed.

Posters are to be 22"x28" and displayed horizontally and placed in a clear plastic sleeve or covered with clear plastic to protect contents. Display boards should be designed to sit on a table using no more than 36" of tabletop space. Space should be left in the lower right-hand corner to place an exhibit tag provided by Purdue Extension staff.

Youth may exhibit in the operator skills option, educational exhibit option or both. Youth choosing to exhibit in the lawn and garden tractor, tractor, or zero-turn mower operator skills driving option must select one, but may be enrolled in all three projects.

Judges evaluating exhibits should recognize individual differences and creativity, therefore using information in this document as a guide rather than a requirement.

Level A—Grades 3, & 4

- Create an educational poster, notebook or display about any manual activity or on any tractor safety, maintenance, operating system or operation topic of choice that is age/grade appropriate.
- Turn in record sheet.

Level B—Grades 5 & 6

- Create an educational poster, notebook or display about any manual activity or on any tractor safety, maintenance, operating system or operation topic of choice that is age/grade appropriate.
- Turn in record sheet.

Level C—Grades 7, 8, & 9

- Create an educational poster, notebook or display about any manual activity or on any tractor safety, maintenance, operating system or operation topic of choice that is age/grade appropriate.
- Turn in record sheet.

Level D—Grades 10, 11, & 12

- Create an educational poster, notebook or display about any manual activity or on any tractor safety, maintenance, operating system or operation topic of choice that is age/grade appropriate.
- **OR** youth can also design and complete an independent study activity.

OPERATOR SKILLS OPTION

State Fair Entries

- 3 junior and 3 senior driving contestants will qualify at the **county** level to compete at the area level contest.
- 3 junior and 3 senior driving contestants will qualify at the **area** level to compete at the state contest.

Materials Available:

- Tests and Parts identification are available on the Internet at:
<https://extension.purdue.edu/4-H/projects/4-h-project-tractor-and-mower-safety-and-operator-skills.html>

Junior Division—Grades 3, 4, 5, 6, & 7

Youth will demonstrate their operation skills by driving a tractor and wagon or trailer through an obstacle course as outlined in 4-H 84, Conducting 4-H Operator Safety Contests.

https://extension.purdue.edu/4h/Documents/4-H_84_Conducting_Petroleum_Power_contests.pdf

Senior Division—Grades 8, 9, 10, 11, & 12

Youth will demonstrate their operation skills by driving a tractor and wagon or trailer through an obstacle course as outlined in 4-H 84, Conducting 4-H Operator Safety Contests.

https://extension.purdue.edu/4h/Documents/4-H_84_Conducting_Petroleum_Power_contests.pdf

1. All participants will be scored on written quiz, parts identification, tractor operation on the course, safety while at the contest and time.
2. **Junior contestants** will pull a 2-wheel trailer approximately eight (8) feet wide and 10-12 feet long. Tongue length will be approximately four (4) feet, as measured from the tongue's tip to the edge of the trailer's bed. Wheel location will be near the center of the bed.
3. **Senior contestants** will pull a 4-wheel wagon with knuckle-type radius rods (auto type) steering, approximately ten (10) feet long between axles, an 8-foot x 14-foot bed and a 52-inch stub tongue.
4. Any stake knocked over by the contestants (with any part of the tractor or wagon) will be replaced and the contestant must attempt the obstacle until satisfactorily completed or until time expires.
5. The written quiz will consist of 25 multiple choice questions, with 20 points added for each question answered incorrectly or omitted.
6. The parts identification quiz will consist of 25 parts. 20 points will be added to the contestant's score for each part incorrectly identified. **Note:** Pictures will be used for this component.
7. **Junior division** questions will be taken from supplement #1, **Questions and Answers for Junior division Written Test**, dated 2003. **Senior division** questions will be taken from supplement #2 **Questions and Answers for Senior division**, dated 2003, **PLUS**, supplement #1 mentioned above.
8. The driving event will be timed and will be scored on the basis of one (1) penalty point for each second. However, other penalty points for safety violations, hit markers, etc., will be so severe that the importance of speed will be minimized.
9. Terms and conditions will be as outlined in 4-H 84 **Conducting 4-H Petroleum Power Operators Contest**.

ZERO-TURN MOWER SAFETY AND OPERATOR SKILLS

For this project, you may choose to do a poster, notebook, or display AND/OR participate in the operator skills contest. You may choose to do one of them or both of them.

EDUCATION OPTION

State Fair Entries:

- 4 educational exhibits per county; 1 per level

Manuals:

- Level A—Starting Up: Getting to Know Your Tractor
- Level B—Tractor Operations: Gearing Up for Safety
- Level C—Moving Out: Learning About Your Tractor and Farm Machinery
- Level D—Learning More: Learning About Agricultural Tractors & Equipment

Exhibit Guidelines:

All posters, notebooks, and display boards must include a reference list indicating where information was obtained, giving credit to the original author, to complete the 4-H member's exhibit. This reference list should/might include web site links, people and professionals interviewed, books, magazines, etc. It is recommended this reference list be attached to the back of a poster or display board, be the last page of a notebook, or included as part of the display visible to the public. A judge is not to discredit an exhibit for the way references are listed.

Posters are to be 22"x28" and displayed horizontally and placed in a clear plastic sleeve or covered with clear plastic to protect contents. Display boards should be designed to sit on a table using no more than 36" of tabletop space. Space should be left in the lower right-hand corner to place an exhibit tag provided by Purdue Extension staff.

Youth may exhibit in the operator skills option, educational exhibit option or both. Youth choosing to exhibit in the lawn and garden tractor, tractor, or zero-turn mower operator skills driving option must select one, but may be enrolled in all three projects.

Judges evaluating exhibits should recognize individual differences and creativity, therefore using information in this document as a guide rather than a requirement.

Level A—Grades 3, & 4

- Create an educational poster, notebook or display about any manual activity or on any zero-turn mower safety, maintenance, operating system or operation topic of choice that is age/grade appropriate.
- Turn in record sheet.

Level B—Grades 5 & 6

- Create an educational poster, notebook or display about any manual activity or on any zero-turn mower safety, maintenance, operating system or operation topic of choice that is age/grade appropriate.
- Turn in record sheet.

Level C—Grades 7, 8, & 9

- Create an educational poster, notebook or display about any manual activity or on any zero-turn mower safety, maintenance, operating system or operation topic of choice that is age/grade appropriate.
- Turn in record sheet.

Level D—Grades 10, 11, & 12

- Create an educational poster, notebook or display about any manual activity or on any zero-turn mower safety, maintenance, operating system or operation topic of choice that is age/grade appropriate.
- **OR** youth can also design and complete an independent study activity.
- Turn in record sheet.

State Fair Entries

- 3 junior and 3 senior driving contestants will qualify at the **county** level to compete at the area level contest.
- 3 junior and 3 senior driving contestants will qualify at the **area** level to compete at the state contest.

Materials Available:

- Tests and Parts identification are available on the Internet at:
<https://extension.purdue.edu/4-H/projects/4-h-project-tractor-and-mower-safety-and-operator-skills.html>

Junior Division—Grades 3, 4, 5, 6, & 7

Youth will demonstrate their operation skills by driving a zero-turn mower through an obstacle course as outlined in 4-H 84, Conducting 4-H Operator Safety Contests.

https://extension.purdue.edu/4h/Documents/4-H_84_Conducting_Petroleum_Power_contests.pdf

Senior Division—Grades 8, 9, 10, 11, & 12

Youth will demonstrate their operation skills by driving a zero-turn mower through an obstacle course as outlined in 4-H 84, Conducting 4-H Operator Safety Contests.

https://extension.purdue.edu/4h/Documents/4-H_84_Conducting_Petroleum_Power_contests.pdf

1. All participants will be scored on written quiz, parts identification, tractor operation on the course, safety while at the contest and time.
2. Any stake knocked over by the contestants (with any part of the tractor or wagon) will be replaced and the contestant must attempt the obstacle until satisfactorily completed or until time expires.
3. The written quiz will consist of 25 multiple choice questions, with 20 points added for each question answered incorrectly or omitted.
4. The parts identification quiz will consist of 25 parts. 20 points will be added to the contestant's score for each part incorrectly identified. **Note:** Pictures will be used for this component.
5. **Junior division** questions will be taken from supplement #1, **Questions and Answers for Junior division Written Test**, dated 2003. **Senior division** questions will be taken from supplement #2 **Questions and Answers for Senior division**, dated 2003, **PLUS**, supplement #1 mentioned above.
6. The driving event will be timed and will be scored on the basis of one (1) penalty point for each second. However, other penalty points for safety violations, hit markers, etc., will be so severe that the importance of speed will be minimized.
7. Terms and conditions will be as outlined in 4-H 84 **Conducting 4-H Petroleum Power Operators Contest**.

TRAVELOGUE

(Listed under Collections and Hobbies)

No State Fair Exhibits

Level 1—Grades 3, 4, & 5

Level 2—Grades 6, 7, & 8

Level 3—Grades 9, 10, 11, & 12

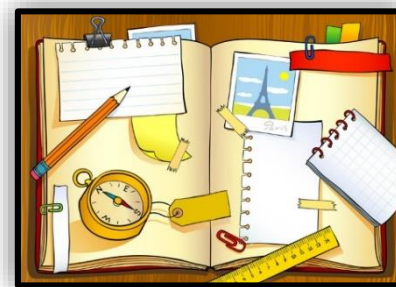

Manual:

- Fulton County Travelogue Manual

Level 1—Grades 3, 4, & 5

Project Completion: Turn in completed Travelogue Record Sheet to finish the project.

Exhibit: Exhibit a notebook or scrapbook containing the following information:

- Journal or Story or use pictures or post cards to tell your story
- Length of trip
- Pictures
- Map of route
- Souvenirs
- Travelogue Record Sheet
- Individual packing list (Optional)

Level 2—Grades 6, 7, & 8

Project Completion: Turn in completed Travelogue Record Sheet to finish the project.

Exhibit: Exhibit a notebook or scrapbook containing the following information:

- Journal or Story—written
- Itinerary
- Pictures
- Map of route
- Souvenirs
- Individual packing list
- Travelogue Record Sheet

Level 3—Grades 9, 10, 11, & 12

Project Completion: Turn in completed Travelogue Record Sheet to finish the project.

Exhibit: Exhibit a notebook or scrapbook containing the following information:

- Journal or Story—written
- Itinerary
- Pictures
- Map of route
- Budget including cost comparison of one expense category
- Checklist of things to do before the trip
- Packing list
- Travelogue Record Sheet

VETERINARY SCIENCE

State Fair—3 per county; 1 per level

- Beginner Level 1—Grades 3, 4, & 5
- Intermediate Level 2—Grades 6, 7, & 8
- Advanced Level 3—Grades 9, 10, 11, & 12

Manual:

- Veterinary 1: From Airedales to Zebras
- Veterinary 2: All Systems Go!
- Veterinary 3: On the Cutting Edge



Exhibit Guidelines:

All posters, notebooks, and display boards must include a reference list indicating where information was obtained, giving credit to the original author, to complete the 4-H member's exhibit. This reference list should/might include web site links, people and professionals interviewed, books, magazines, etc. It is recommended this reference list be attached to the back of a poster or display board, be the last page of a notebook, or included as part of the display visible to the public. A judge is not to discredit an exhibit for the way references are listed.

Posters are to be 22"x28" and displayed horizontally and placed in a clear plastic sleeve or covered with clear plastic to protect contents. Display boards should be designed to sit on a table using no more than 36" of tabletop space. Space should be left in the lower right-hand corner to place an exhibit tag provided by Purdue Extension staff.

Judges evaluating exhibits should recognize individual differences and creativity, therefore using information in this document as a guide rather than a requirement.

This project provides a hands-on learning experience that helps youth learn more about the Veterinary Science profession.

Beginner Level 1—Grades 3, 4, & 5

- Create an educational poster, notebook or display about any manual activity or on any veterinary science topic of choice that is age/grade appropriate.
- Turn in the record sheet.

Intermediate Level 2—Grades 6, 7, & 8

- Create an educational poster, notebook or display about any manual activity or on any veterinary science topic of choice that is age/grade appropriate.
- Turn in the record sheet.

Level 3—Grades 9, 10, 11, & 12

- Create an educational poster, notebook or display about any manual activity or on any veterinary science topic of choice that is age/grade appropriate.
- **OR** youth may also choose to develop a teaching aid, develop a project in conjunction with a veterinarian and present a report about that project and its findings.
- **OR** another report of your choosing.
- Turn in the record sheet.

WEATHER AND CLIMATE SCIENCE

State Fair—3 per county; 1 per level

- Beginner Level 1—Grades 3, 4, & 5
- Intermediate Level 2—Grades 6, 7, & 8
- Advanced Level 3—Grades 9, 10, 11, & 12

Youth will learn basic information about weather and climate science, including what causes variations in weather and why we have different seasons and climates on the earth. In this project you will observe and record weather conditions and learn weather symbols.

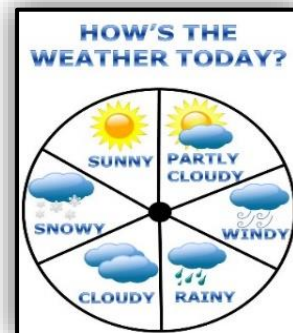

Manual:

- Weather and Climate Science, Level 1 (Manual or PDF Available)
- Weather and Climate Science, Level 2 PDF
- Weather and Climate Science, Level 3 PDF

Exhibit Guidelines:

All posters, notebooks, and display boards must include a reference list indicating where information was obtained, giving credit to the original author, to complete the 4-H member's exhibit. This reference list should/might include web site links, people and professionals interviewed, books, magazines, etc. It is recommended this reference list be attached to the back of a poster or display board, be the last page of a notebook, or included as part of the display visible to the public. A judge is not to discredit an exhibit for the way references are listed.

Posters are to be 22"x28" and displayed horizontally and placed in a clear plastic sleeve or covered with clear plastic to protect contents. Display boards should be designed to sit on a table using no more than 36" of tabletop space. Space should be left in the lower right-hand corner to place an exhibit tag provided by Purdue Extension staff.

Judges evaluating exhibits should recognize individual differences and creativity, therefore using information in this document as a guide rather than a requirement.

Beginner Level 1—Grades 3, 4, & 5

Exhibit

- Create an educational poster, notebook or display about any manual activity or on any weather and climate topic of choice that is age/grade appropriate.
- Turn in record sheet

Intermediate Level 2—Grades 6, 7, & 8

Exhibit

- Create an educational poster, notebook or display about any manual activity or on any weather and climate topic of choice that is age/grade appropriate.
- Turn in record sheet

Advanced Level 3—Grades 9, 10, 11, & 12

Exhibit

- Create an educational poster, notebook or display about any manual activity or on any weather and climate topic of choice that is age/grade appropriate.
- **OR** youth can also design and complete an independent study activity.
- Turn in record sheet



WELDING

No State Fair Exhibit

Grades 6 & 7
 Grades 8 & 9
 Grades 10 & 11
 Grade 12

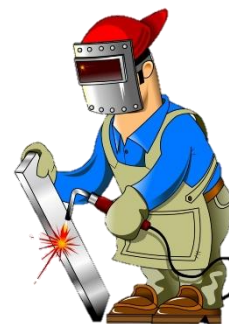

Exhibit Guidelines:

This project is open to people in 6th-12th grade. There will be 4 levels of participation. You will learn about different welding skills and how to do different projects.

Grades 6 & 7

Complete a sheet explaining welding safety that will accompany your exhibit. Exhibit one of the following:

- A sample weld
- A joint weld
- A small project

Grades 8 & 9

Complete a sheet explaining welding symbols that will accompany your exhibit. Exhibit one of the following:

- A sample weld using overhead welds
- A joint weld using overhead welds
- A small project using overhead welds

Grades 10 & 11

Complete a sheet explaining the different types of welding rods and their uses. This should accompany your exhibit. Exhibit one of the following:

- A sample weld using out of position welds
- A joint weld using out of position welds
- A small project using out of position welds

Grade 12

The member *may choose* to make their project using a Mig (wire) welder. Accompanying this *shall be* a paper explaining the use of different gases, different alloys, and different wires.

WILDLIFE

State Fair—3 per county; 1 per level

Beginner Level 1—Grades 3, 4, & 5

Intermediate Level 2—Grades 6, 7, & 8

Advanced Level 3—Grades 9, 10, 11, & 12



Manual:

- Wildlife, Level 1
- Wildlife, Level 2
- Wildlife, Level 3

Additional Resources Available:

- National Wildlife Habitat Education Program Manual

Exhibit Guidelines:

All posters, notebooks, and display boards must include a reference list indicating where information was obtained, giving credit to the original author, to complete the 4-H member's exhibit. This reference list should/might include web site links, people and professionals interviewed, books, magazines, etc. It is recommended this reference list be attached to the back of a poster or display board, be the last page of a notebook, or included as part of the display visible to the public. A judge is not to discredit an exhibit for the way references are listed.

Posters are to be 22"x28" and displayed horizontally and placed in a clear plastic sleeve or covered with clear plastic to protect contents. Display boards should be designed to sit on a table using no more than 36" of tabletop space. Space should be left in the lower right-hand corner to place an exhibit tag provided by Purdue Extension staff.

Judges evaluating exhibits should recognize individual differences and creativity, therefore using information in this document as a guide rather than a requirement.

Beginner Level 1—Grades 3, 4, & 5

Exhibit

- Create an educational poster, notebook, or display about any manual activity or on any wildlife topic of choice that is age/grade appropriate.
- Turn in record sheet

Intermediate Level 2—Grades 6, 7, & 8

Exhibit

- Create an educational poster, notebook, or display about any manual activity or on any wildlife topic of choice that is age/grade appropriate.
- Turn in record sheet

Advanced Level 3—Grades 9, 10, 11, & 12

Exhibit

- Create an educational poster, notebook, or display about any manual activity or on any wildlife topic of choice that is age/grade appropriate.
- **OR** youth can also design and complete an independent study activity.
- Turn in record sheet

WOODWORKING

State Fair—4 per county; 1 per level

Level 1—Grades 3 & 4

Level 2—Grades 5 & 6

Level 3—Grades 7, 8, & 9

Level 4—Grades 10, 11, & 12

The 4-H woodworking project provides youth with educational information about wood and how it can be used to construct items.

Needed for Judging:

- Woodworking Record Sheet
- **Woodworking Skills Sheet submitted with your Record Sheet**
- Woodworking Plans for Level 1 & 2



Manual:

- Woodworking 1, Measuring Up
- Woodworking 2, Making the Cut
- Woodworking 3, Nailing it Together
- Woodworking 4, Finishing Up

Exhibit Guidelines:

All posters, notebooks, and display boards must include a reference list indicating where information was obtained, giving credit to the original author, to complete the 4-H member's exhibit. This reference list should/might include web site links, people and professionals interviewed, books, magazines, etc. It is recommended this reference list be attached to the back of a poster or display board, be the last page of a notebook, or included as part of the display visible to the public. A judge is not to discredit an exhibit for the way references are listed.

Posters are to be 22"x28" and displayed horizontally and placed in a clear plastic sleeve or covered with clear plastic to protect contents. Display boards should be designed to sit on a table using no more than 36" of tabletop space. Space should be left in the lower right-hand corner to place an exhibit tag provided by Purdue Extension staff.

Judges evaluating exhibits should recognize individual differences and creativity, therefore using information in this document as a guide rather than a requirement.

Level 1—Grades 3 & 4

Exhibit

- One article of choice made during the current 4-H program year demonstrating a minimum of five (5) techniques outlined in the [Indiana 4-H Woodworking Tools, Techniques and Skills Chart 4-H 6875C-W](#).
- Exhibits may also include higher level techniques that have been mastered. Any higher level techniques will not be counted as part of the minimum five, but nevertheless will be evaluated for quality.
- **A woodworking skills sheet is to be submitted** with the exhibit for judging. Skills sheets are for judging purposes only and will not be returned to the exhibitor.
- Youth may also choose to create an educational poster, notebook or display about any manual activity or on any woodworking topic of choice that is age/grade appropriate.
- Turn in the record sheet with your project.

Level 2—Grades 5 & 6

Exhibit

- One article of choice made during the current 4-H program year demonstrating a minimum of five (5) techniques outlined in the [Indiana 4-H Woodworking Tools, Techniques and Skills Chart 4-H 6875C-W](#).
- Exhibits may also include lower and/or higher level techniques that have been mastered. Any lower/higher level techniques will not be counted as part of the minimum five, but nevertheless will be evaluated for quality.
- **A woodworking skills sheet is to be submitted** with the exhibit for judging. Skills sheets are for judging purposes only and will not be returned to the exhibitor.
- Youth may also choose to create an educational poster, notebook or display about any manual activity or on any woodworking topic of choice that is age/grade appropriate.
- Turn in the record sheet with your project.

Level 3—Grades 7, 8, & 9

Exhibit

- One article of choice made during the current 4-H program year demonstrating a minimum of five (5) techniques outlined in the [Indiana 4-H Woodworking Tools, Techniques and Skills Chart, 4-H 6875C-W](#).
- Exhibits may also include lower and/or higher level techniques that have been mastered. Any lower/higher level techniques will not be counted as part of the minimum five, but nevertheless will be evaluated for quality.
- **A woodworking skills sheet is to be submitted** with the exhibit for judging. Skills sheets are for judging purposes only and will not be returned to the exhibitor.
- Youth may also choose to create an educational poster, notebook or display about any manual activity or on any woodworking topic of choice that is age/grade appropriate.
- Turn in the record sheet with your project.

Level 4—Grades 10, 11, & 12

Exhibit

- One article of choice made during the current 4-H program year demonstrating a minimum of five (5) techniques outlined in the [Indiana 4-H Woodworking Tools, Techniques and Skills Chart, 4-H 6875C-W](#).
- Exhibits may also include lower level techniques that have been mastered. Any lower level techniques will not be counted as part of the minimum five, but nevertheless will be evaluated for quality.
- **A woodworking skills sheet is to be submitted** with the exhibit for judging. Skills sheets are for judging purposes only and will not be returned to the exhibitor.
- Youth may also choose to create an educational poster, notebook or display about any manual activity or on any woodworking topic of choice that is age/grade appropriate.
- Turn in the record sheet with your project.



Indiana 4-H Woodworking Tools, Skills and Techniques

Youth and their mentor/volunteer leader/instructor should use this chart as a guide when deciding appropriate tools and skills to use and incorporate in a woodworking exhibit. While this list is a guide, it is not meant to be an all-inclusive list and youth should demonstrate skills they are most comfortable mastering with tools used. For example, some youth in level 2 might feel comfortable attempting level 3 tools/skills, but it is unlikely that a level 1 exhibitor will be able to successfully master the level 4 tools/skills. Youth are encouraged to utilize a number of resources such as web sites, print material, social media, and television shows when learning woodworking skills. Skills learned from these types of resources may be demonstrated provided they are age/grade appropriate.

The "X" indicates suggested level to learn respective skill. Exhibits must include a minimum of 5 techniques from their level indicated in the chart below but may include additional techniques from other levels as deemed appropriate, but nevertheless will be evaluated for quality. For example, Level 3 exhibitors may use any techniques found in Level 1 or Level 2 but the exhibit must include a minimum of 5 Level 3 techniques. Level 4 may use any techniques found in the lower three levels but must have a minimum of 5 Level 4 techniques.

SKILL	LEVEL 1	LEVEL 2	LEVEL 3	LEVEL 4
SAFETY (Required of all levels and not counted as a Skill or Technique)				
Ear Protection	X	X	X	X
Eye Protection	X	X	X	X
Shop Organization	X	X	X	X
Machine Guards	X	X	X	X
LAYOUT				
Ruler	X			
Tape Measure	X			
Square	X			
COMMON TOOLS				
Hammer	X			
Handsaw	X			
Coping Saw	X			
Scroll Saw	X			
Screw Driver	X			
Wood Chisel	X			
Pliers	X			
Hand Plane		X		
POWER TOOLS				
Band Saw	X			
Table Saw		X		
Electric Drill		X		
Radial Arm Saw			X	
Circular Saw			X	
Planner				X
Lathe				X
Jointer				X
Miter Saw				X
Scroll Saw			X	X

MATERIAL SELECTION				
Wood	X			
Wood Products	X			
Plywood	X			
Fiberboard	X			
Synthetic Products			X	X
JOINTS				
Lap Joint	X			
Butt Joints	X			
Basket Joints		X		
Doweled Joints		X		
Mortise and Tenon Joints			X	
Dado Joints			X	
Miter Joint				X
Dovetail Joints				X
Box Joints			X	X
TABLE ROUTING				
Bevels			X	
Dadoing			X	
Rabbeting			X	
Planing				X
Jointing				X
FASTENERS				
Screws	X			
Nails	X			
Bolting	X			
Gluing	X			
Pocket Hole Fasteners		X		
Brad Nailer				X
FINISHING				
Sanding	X			
Penetrating Finish	X			
Painting	X			
Varnishing		X		
Spraying				X
FREEHAND ROUTING				
Bevels			X	
Dadoing			X	
Rabbeting			X	
Planing				X
Jointing				X

4-H Animal Rules And Requirements



Fulton County Limits:

Beef and Dairy Beef Steers – 6 Total Steers

Commercial & Market Heifers and Dairy Feeder Calves – 6 Total

Beef, Registered Heifers 6 Total Heifers

Dairy Cattle – 40 Total

Dairy Goats Females, Registered or Wethers – 15 Goats Total

Meat Goat Wethers, Boer Goat Females, Registered, Market Goat Does – 15 Goats Total

Pygmy Goats Registered and Unregistered – 15 Goats Total

Horse and Pony – 3 Total

Sheep – 10 Market, 10 Ewes, 10 Yearling Ewes

Swine – 15 Gilts and 15 Barrows Fulton County Beef Show Rules Update

A few important updates to the Beef guidelines that are now effective starting with the 2022 Fulton County Beef show.

All eligible breeds for Heifers and Steers will be the same as listed in the State Fair Guidelines. To be eligible to participate in REGISTERED classes Heifers AND Steers will be required to have registration papers with the animal having matching tattoos. The registration papers must be in the 4-H exhibitors name or the family name.

For Heifers and Steers that have Breed Registries that currently or in the future have multiple breed categories recognized there will be an overall Breed Champion awarded for that Breed, for both Heifers and Steers. The Overall Breed Champion for Heifers and Steers will represent that Breed in the Grand drive. Each Breed category will first have its designated class or classes with the champion being recognized. The Breed categories will then compete for the overall Breed Champion trophy, for both Heifers and Steers.

Breeds that currently have multiple categories for Heifers: Maine Anjou, Simmental, Shorthorn, Charolais, and Hereford. For Steers: Shorthorn, and Hereford. If there are additional Breed categories recognized by the State Fair rule book those will automatically be added to this list.

For proper animal entry and eligibility:

1. For registered steers, bring registration papers to weigh in entry day. For a steer to show in a registered breed class the animal must be registered and have registration information available on the weigh in entry date in March. If registration information is not available at the weigh in held in March, the animal will be entered as a crossbred, and will show as a crossbred at the 4-H show.
2. For all registered heifers and registered steers, complete all required registration information on enrollment papers.
3. For all beef exhibits, complete online fair entry with all required information. The online entry must be completed by the advertised deadline which is May 15.



2022 Indiana 4-H Animal Identification

The following table lists the different animal species and the respective form of identification that is required for a 4-H member to be eligible to show in the 4-H livestock shows at the 2022 Indiana State Fair. The animal ID information must be entered in the Indiana 4-H Online enrollment system by the respective deadlines. Missing, incomplete or incorrect animal ID information could result in state fair ineligibility for that particular animal.

	For State Fair	Max # to Enroll	Deadline
Beef and Dairy Beef Steers	840-RFID Tag and 5-digit County Tag and DNA Hair Sample	10 Total steers	May 16
Commercial and Market Heifers and Dairy Feeder	840-RFID Tag and 5-digit County Tag and DNA Hair Sample	10 total	May 16
Beef, Registered Heifers	840-RFID tag and Tattoo and DNA Hair Sample	10 total heifers	May 16
Dairy Cattle	840-RFID tag and animal's registered name and registration number (or dam's registration number) and DNA Hair Sample	40 total	May 16
Dairy Goat Females, Registered	Breed Registry Tattoo	40 dairy goats total	May 16
Wethers	5-digit County Tag or Tattoo		
Meat Goat Wethers	840-RFID Tag and 5-digit County Tag and DNA Hair Sample	40 meat goats total	May 16
Boer Goat Females, Registered	Breed Registry Tattoo and DNA Hair Sample		May 16
Market Goat Does (Wether Dams)	840-RFID Tag and 5-digit County Tag and DNA Hair Sample		May 16
Pygmy Goats Registered	Breed Registry Tattoo or Microchip that Matches Registration Papers	40 total	May 16
Unregistered	Official USDA Scrapie Tag or Official Scrapie Tattoo		
Horses and Pony	Color Picture	20 total	May 16
Llama and Alpaca	Color Picture	20 total	May 16
Sheep Market Lambs	840-RFID Tag and 5-digit County Tag and DNA Hair Sample	30 sheep total	May 16
Commercial Ewes	840-RFID Tag and 5-digit County Tag/or official scrapies tag and DNA Hair Sample		
Registered Ewes	840-RFID Tag and ID that matches registration Papers and DNA Hair Sample		
Swine	840-RFID Tag and Ear Notch and DNA Hair Sample	15 Gilts 15 Barrows	May 16

SELECTION & RESPONSIBILITIES OF DEPARTMENTS & DEPARTMENT HEADS

Beef, Cats, Community Building, Dairy, Dog, Goats, Poultry, Rabbits, Sheep, & Swine

At the annual September meeting of the 4-H Departments, the department will reorganize and then review rules and recommend changes to be presented to the 4-H Council in October and/or November. Committee recommendations may be made no later than November 15. Reorganization will consist of:

1. Interested persons not currently part of the department may be added to the department upon a vote of department members present.
2. Accepting resignations of any current department members wanting off.
3. Department members present may vote to remove any current members they feel are not participating.
4. Voting rights within the department are bestowed upon adult department members only. 4-H members will be asked to be involved in as many departments as they have interest. There will be one vote from the 4-H members in each department—either 1 member may vote or decide as a team. This decision is left up to the Department Head as to how the 4-H member vote is chosen.
5. All votes shall be conducted by secret ballot with a simple majority of those members present required.
 - Departments shall have from 5 to 17 adult members—depending upon the needs of each particular department.
 - The newly reorganized department will be responsible for selecting their Department Head.
 - Department Heads will serve a three-year term.
 - An individual shall actively serve on a department for at least three consecutive years before being eligible to be selected as Department Head.

DEPARTMENT HEAD INFORMATION

DEPARTMENT HEADS will be the 4-H Council representative, serve on the Livestock Auction Committee (except Community Building, Horse and Pony, Cat, and Dog) and on the Awards Selection Committee. The Department Head is responsible for making sure that the following tasks are performed:

1. Setting up, tearing down, and storing materials for the following year.
2. Making pen assignments. (Livestock only)
3. Checking in and releasing projects at the fair.
4. Arranging classes and show order (if not outlined in the Project Summary Guide). (Livestock only)
5. Fair judging:
 - Listing prospective judges
 - Supervising exhibits and/or show and/or arranging Community Building displays
 - Making sure that exhibitors receive their ribbons, trophies and awards, securing award sponsors
 - Turning in sale order to the Extension Office a half hour after the show; swine within the hour after the show
 - Proofread sale information
 - Recording grades and placings in office folders. Submitting placings and 3-ring binder to Extension Office within 24 hours after show ends
6. Presenting project changes in Summary Guide during the fall.
7. Working with Extension Educator to arrange for livestock enrollment identification, including: Retinal image scanning, ear tagging and/or tattooing, and weighing. (Livestock only.)
8. Other (if something is not on this list).

2022 LIVESTOCK DEPARTMENT HEADS & COMMITTEES

Beef

Department Head: Ron Clauson

Committee Members: R.D. Burns, Scott Burton, Renell Finke, Letitia Geller, Joe Hunting, **Stephanie McCulley***, Lori Myers, **Arik Owens***, Justin Pearson, Chris Riffle, Barry Scales, **Dan Showley***

4-H Members:

Cats

Department Head: Amanda DeSonia

Committee Members:

4-H Members: Kaylee DeSonia

Dairy

Department Head: Rick Rock

Assistant: Tammy Vigar

Committee Members: Jeannie Rock, Sandy Rock, Tammy Vigar, Jessie Rock-Wolf

4-H Members: Emily Vigar,

Dogs

Department Head: Penny Conover

Assistant: LeeAnn Pollock

Committee Members: Bree Bailey, Stephanie Bailey, Kris Batten, Elliot Corner, Malarie Corner, Megan Dennis, Terri Dennis, Kent Denny, Judy Evans, Alicia Fuller, Stacie Heiman, Shari Miller, Kris Robison, Eric Schlarf, Tammy Schlarf, Lindsay Straeter

4-H Members: Ellie Fuller, Haley Robison, Kaillie Woods

Goats

Department Head: Kandace Evers

Committee Members: **Lisa Becker***, Angela Brunk, Evan Cohagan, Myron Cohagan, Maggie Rock, Tammy Vigar, Kristin Woods

4-H Members: Reagan Becker, Amanda Evers, Emily Vigar

Horse & Pony

Department Heads: Julie Moore & Leslie Crissinger

Committee Members: Jenny Brewer, Trudy Cahill, Harry Caudill, Linda Herendeen, Tara Koebcke, David Leavell, Jordan Moore, Joshua Moore, **Jon Newell***, Keisha Troutman, Jessa Wilhelm, Kristin Woods

Poultry

Department Head: Amber Edmondson

Committee Members: Jaime Taylor

4-H Members:

Rabbits

Department Heads: Beth Cohagan & RaeAnn Reichard

Committee Members: McKenna Grossman, Erin Nelson, Rolanda Reichard, Sandy Rock, Kristin Woods

4-H Members: Emmalie Grossman, Kolyn Grossman, Terry Grossman, Addie Nelson, Brooke Nelson

Sheep

Department Heads: Jenny Stiffler & Lori Stiffler

Committee Members: Joe Crill, Priscilla Crill, **Larry Cripe***, **Reba Cripe***, Lee Ann Eizinger, Lacey Jones, Mike Jones, Greg Leininger, Megihann Leininger, Jessica Melton, Mitch Melton, Shari Miller, Tom Smith, Jaclyn Murphy

Swine

Department Head: Jenn Lukens

Assistant: Curt Kline

Committee Members: Damic Beck, Becky Cave, **Chris Gardner***, **Mike Harsh***, **Brett Hizer***, **Steven King***, Gus Lukens, Linc Lukens, Micah Lukens, Hank Riffle, Barry Scales, Kevan Secrist, Evan Young

Non-Voting Committee Members: Ryan Baker, **Deric Beck**, Scott Burton, Kyle Clauson, Cathie Lukens, Josh Overmyer, **Nick Overmyer**, **Aaron Ramsey** Riley Reichard, Brittany Riffle, Kyle Riffle, **Kyle Secrist**

4-H Members:

Livestock Sale Committee

Co-Chairmen: Glen Jones & Whitley Moser

Members: **Brian Bauman**, **Ross Burdge**, Amy Calvert, Ron Clauson, Beth Cohagan, Amber Edmondson, Kandace Evers, Renell Finke, **Chris Gardner**, Joe Hunting, Jenn Lukens, **Steve Metzger**, Shari Miller, Kyle Riffle, Rick Rock, Barry Scales, **Andrew Schouten**

Names with * still need to finish volunteer paperwork.

4-H LIVESTOCK SALE GUIDELINES

1. Sale order shall rotate every year. Rotation moves last to first the following year.
2. Members are limited to selling 1 animal that they have exhibited in any 2 of the following project areas: Beef, Dairy, Goat, Poultry, Rabbit, Sheep, and Swine. A dairy exhibitor (cattle or goat) may sell a product basket if they have no other animal project to sell. An egg exhibitor may sell a product basket if they have no animal project to sell.
3. Participation in the 4-H Livestock Sale is completely voluntary.
4. 4-H members and their families are encouraged to contact and recruit prospective buyers. This is not the sole responsibility of the 4-H Livestock Sale Committee.
5. The check-in weight will be sale weight.
6. Checks will be made available after all funds have been collected from the buyers.
7. Livestock projects must be sold by the owner except in emergency situations such as injury or illness. All other substitutions must have prior 4-H Livestock Sale Committee approval. All requests must be submitted in writing.
8. The General Sale Commission will be 3% with the exception of 4-H members participating in the Spotlight Sale, where the commission is 5.5%.
9. An Affidavit will be used for sale animals, stating the animal is drug free. Forms will be attached to record sheets.
10. Selling of items, (non-4-H member livestock exhibits) will need prior approval 1 week before the fair from the Livestock Sale Committee. The consignor of these items must have a bid of at least \$200.00 before the item will be considered for acceptance in the sale.
11. Each livestock project department head or a representative chosen by the department head will hold a spot on the livestock sale committee.

2022 FULTON COUNTY 4-H ANIMAL DEADLINES

Animal Enrollment Deadlines	
Species	Deadline
Beef (Beef Steer, Dairy Steer & Commercial Heifers) through 4-H Online	May 15
Beef (Registered Heifers) through 4-H Online	May 15
Cat	May 15
Dairy	May 15
Dairy Calf Feeder Steer through 4-H Online	May 15
Dog	May 15
Goat through 4-H Online	May 15
Horse & Pony through 4-H Online	May 15
Sheep through 4-H Online	May 15
Swine through 4-H Online & County Bred & Born form (must be tagged BEFORE THE 15th if going to the state fair)	May 16
DNA Sample for Beef, Feeder Calf, Dairy, Goats, Sheep & Swine into office IF GOING TO STATE FAIR	May 15
Poultry paper form to the office	May 15
Rabbit paper form to the office	May 15
State Fair Deadline to register Dairy, Sheep, Goats, Beef & Feeder Calf, Swine, without penalty	July 1
State Fair Deadline to register Dogs, Cats, Horse & Pony, Poultry, Rabbits without penalty	July 1
ALL PROJECTS MUST BE REGISTERED IN FairEntry.com—ANIMALS AND NON-WALKING	July 1

2022 Weigh-in/Tag			
Species	Date	Time	Location
Beef, Dairy Steer	Saturday, March 5, 2022	9:00-11:00 a.m.	Fairgrounds
Commercial Non-Registered	Saturday, March 5, 2022	9:00-11:00 a.m.	Fairgrounds
Sheep	Friday, May 6, 2022	5:30-7:00 p.m.	Fairgrounds
All Feeder Calves	Saturday, May 7, 2022	9:00-10:00 a.m.	Fairgrounds
Goats	Saturday, May 7, 2022	9:30-10:30 a.m.	Fairgrounds

2022 Fair Check-in		
Species	Date	Time
Swine	Saturday, July 9, 2022	7:00 p.m.-10:00 p.m.
Beef	Sunday, July 10, 2022	11:00 a.m.-1:30 p.m.
Dairy	Sunday, July 10, 2022	11:00 a.m.-1:30 p.m.
Dairy Calf Feeder Steer	Sunday, July 10, 2022	11:00 a.m.-1:30 p.m.
Dairy Steer	Sunday, July 10, 2022	11:00 a.m.-1:30 p.m.
Poultry, Pigeons, & Waterfowl	Sunday, July 10, 2022	12:00 noon-2:00 p.m.
Horse & Pony	Sunday, July 10, 2022	1:00 p.m.-6:00 p.m.
Sheep	Sunday, July 10, 2022	2:00 p.m.-4:00 p.m.
All Goats (Dairy, Boer, Pygmy, & Market Goats)	Sunday, July 10, 2022	4:00 p.m.-5:00 p.m.
Rabbit	Sunday, July 10, 2022	4:00 p.m.-6:00 p.m.

FULTON COUNTY LIVESTOCK EXHIBITS ALL ANIMALS GENERAL GUIDELINES

1. Livestock exhibitors are limited to:
 - Beef which is six (6) steers and six (6) heifers
 - Horse and Pony which is limited to three (3)
 - Poultry which is 15 pens total (see limits)
 - Rabbits which is 3 breeds plus a meat pen (limit 12 pens plus a meat pen)
 - Goats limited to twelve (12) animals and three (3) market goats
 - Sheep which is 2 breeds ewes and 2 breeds market
 - Swine should have a maximum of 6 pigs
2. When a 4-H member has two exhibits in the same livestock class; both exhibits must be shown by a Fulton County 4-H member.
3. Only the judge and/or specifically assigned adult personnel are allowed in the show arena during the show. Once the animal is in the show ring, no fitting other than a brush may be used.
4. For animals that will not be kept at the 4-H member's residence, the member must ask permission from the 4-H Council for the animals to be housed elsewhere. **All housing requests are due at time of enrollment** (January Beef ID or May livestock enrollment deadlines).
5. Each club member should own his own exhibit. Family corporations and/or partnerships of 4-H club member with parent are accepted in classes for breeding animals. 4-H animals in 4-H breeding classes will NOT be accepted at the Fulton County 4-H Fair that are registered in a farm name only. (Such as "Long View", "Long Oak", etc.) Acceptable registrations are:
 - 1) The 4-H member's name
 - 2) John Doe and Sons
 - 3) John Doe Sons & Daughters
 - 4) John Doe and Family—Sons and Daughters
 - 5) John Doe and William Doe
 - 6) Long Oak and William Doe (William Doe being a 4-H member)
 - 7) Family corporations, where the 4-H member's name appears as a holder of stock in the corporation, and proof of same must be supplied on or before the ID deadline.
 - 8) Family partnership where the 4-H member's father, mother, brother, sister, aunt, uncle, grandparent, and/or legal guardian is also in the family partnership and the 4-H member's name appears on the legal, notarized partnership. A copy of the written document must be on file with the Extension Office before the ID deadline.
6. Animals can be owned in partnership with non-family members in classes for breeding animals. Fulton County has a dairy lease program for those not owning dairy cattle or living on a farm using the Indiana State 4-H lease program rules.
7. Members, parents, and leaders are on their honor to exhibit the same animals that were enrolled at the beginning of the project year. 4-H members, if caught substituting or cheating by substitution in any project, will be barred from 4-H in the county.
8. 4-H adult leaders, sponsoring committee members, or 4-H Council committee may check the 4-H animals enrolled for the year any time after enrollment.
9. Health Certificates are not required for any species that BOAH does not require certificates (Cat, Dog, and Horse and Pony require vaccination papers and Poultry requires NPIP papers.) Each livestock committee can reject any unhealthy exhibits for the fair. If you disagree with their decision, you must acquire a veterinarian's approval (at 4-H member's expense) before exhibit is accepted.
10. All purebred non-market animals must be registered to show in a purebred class and department heads will check registration papers at time of entry. (Dairy, Beef, Swine, Sheep, Horse and Pony, and Goats)
11. All barrow, whether, and steer classes will be set up according to weight as determined by that species' committee.
12. Livestock Herdsmanship Award—A Herdsmanship award will be presented in some species. Winners will be announced during the Livestock Sale.
13. 4-H members participating in showmanship must show their own animals unless the judge requests members to switch.

14. **Showmanship:** Showmanship age divisions for livestock classes will be: (except for Horse and Pony and Dog)
 - a. Beginner: 3rd and 4th graders
 - b. Junior—1st Division: 5th and 6th graders
—2nd Division: 7th and 8th graders
 - c. Senior Division: grades 9, 10, 11, 12 or last year in 4-H
 - d. Master: previous winners of Senior Division
15. A Beginner Showmanship winner will move to Junior the following year, a Junior Showmanship winner will move to Senior Showmanship the following year. The winner of Senior Showmanship may move to Master Division if he/she wishes but it is not required.
16. A Master Showmanship class may be held only if there are 2 or more contestants.
17. 4-H Livestock members must comply with the official health requirements for exhibition as stated in this All Projects Summary Guide beginning on page 194.
18. See Section IV, V, & VI of the 4-H Council Organization Information for sale, enrollment, and completion requirements on page 18 of this All Projects Summary Guide
19. 4-Hers must wear appropriate shirt (no bare midriffs or low-cut tops), long pants, slacks, below the knee length skirt or below the knee length culottes and shoes to show and sell all livestock. When showing and selling beef: 4-H members are not allowed to wear tennis shoes or sandals. This rule does not apply to 4-H Dog or Cat members when showing their species. Department Heads will be screening 4-H members to make sure they are following our dress code. Hats and shorts are not to be worn in the sale ring and neither are signs and advertising.
20. No hats are to be worn when exhibiting and selling except horse and pony members when showing.
21. All livestock pens will be cleaned **by 9:00 p.m. Saturday of the Fair**. All pens and stalls must be cleaned and left as found upon arrival or a **\$20 fee** will be assessed.
22. **STATE FAIR ENTRY INFORMATION:** Read Enrollment form and the Indiana State Fair Website.
23. Access to livestock enrollment forms will be available only to Department Heads. Copies can only be made of livestock information for Department Head, 4-Her or legal guardian.
24. There will be a pen check in all barns in an effort to keep pens clean and barns presentable. Each day at 5:00 p.m., there will be a subcommittee made up of members from the respective committee to check pens. Everyone is required to clean out his or her pens daily and the aisle in front of their pen and have them looking good for the 5:00 p.m. check. Each 4-H member exhibiting livestock will be given a warning the first time if their pen is unsatisfactory. The second time that a pen is unsatisfactory; the 4-Her will be fined \$5.00 which will be taken out of the auction check. If the pen still remains unclean a \$5.00 fine will remain each day thereafter.
25. All county and state livestock enrollments will be filled out completely with the following information: breed, sex of animal, ear tag number, registration number, tattoo, ear notches, colored pictures, or other acceptable identification. Enrollment forms will not be accepted without his information.
26. Livestock projects must be shown by the owner except in emergency situations such as injury or illness. All other substitutions must have prior 4-H Council Executive Committee approval. All requests must be submitted in writing. Pre-existing conditions need to be approved at least 48 hours prior to the show. Other situations will be handled as needed.
27. **Livestock will not be released until 10:00 p.m. on Thursday night of the fair. Removing any livestock before 10:00 p.m. without approval of the barn head will result in loss of completion points for that specific project and the 4-H member will not be allowed to sell anything in the auction. Animals may be released by the barn head if the animal is sick, the individual has received prior approval from the 4-H Council to attend another show, or due to weather-related conditions. Exception is for Swine: They will release the Swine on Wednesday night at 10:00 p.m.**
28. All livestock must be out by 12:00 Noon on Friday, except for animals going through the sale and/or arrangement made with barn department heads. All market goats selling in the sale **MUST** be in the sheep barn by 12:00 Noon Friday to sell.
29. Livestock grooming may be done by any Fulton County 4-H volunteer, current and past Fulton County 4-H members, and immediate family (mother, father, brother, sister, stepparents, legal guardian, grandparents), Fulton County 4-H Club Leader, Fulton County Project Department Heads and livestock committee members during the fair. **See specific Sheep grooming guidelines in the Sheep section.**
30. If you plan to help a youth groom an animal at the State Fair and are not a parent of the 4-H member, please contact the 4-H/Youth Extension Educator.

SUPREME SHOWMANSHIP RULES

Guidelines for Contest:

1. Department Superintendents will choose the animals for the contest.
2. No contestant's animals will be used in the contest. (*except dairy*)
3. Show order may be the order shown during the week. (*Dairy, Sheep, Beef, Swine, Goats*)
4. Eligible contestants will consist of the current year's "Master Showman" winner determined by each of the species' committees, and will represent: Beef, Dairy, Goat, Sheep, and Swine. **(Previous years' Showmanship winners must re-qualify.)**
5. Qualifying members will exhibit all species during the Supreme Showmanship Contest including the species in which they qualified for the contest.
6. Contestants will draw for animals they show in each of the respective species just prior to the beginning of the class.
7. Contestants must sign in at the fair office by NOON on Thursday (Goats have 30 minutes following their show to sign up.)
8. At the time of registration, a short resume about the 4-Her is to be filled out which will be read by the announcer during the judging.
9. Judges will rank all contestants for each of the respective species (1-5). Total low score wins.
10. Contestants must provide their own show equipment and supplies prior to the contest. Contestants may not leave the ring once the show starts.
11. Any physical abuse of showmanship animals by a Supreme showmanship participant will result in the immediate disqualification, from the entire supreme Showmanship competition, of the offending party.
12. If a 4-H member is identified as "Master Showman" in more than one species, the showman must pick which species they will represent and the "Reserve Master Showman" from the other species will compete to fulfill all available contestant slots. This needs to be done within 30 minutes of winning a 2nd species, so the Reserve can be notified.
13. Any previous year and present year Senior Showmanship winners are eligible to compete for "Master Showmanship".
14. Past "Supreme Showmanship" winners must requalify in a species and be named the "Master Showman" to be eligible to compete again. Any past "Supreme Showmanship" winner may requalify in the same species won previously.
15. Each participant will give a short speech on how to show the species they represent. Each participant is responsible for getting someone to show that animal while they speak. That person must be a current Fulton County 4-H member. (*Will be scored*)

FRAUD AND DECEPTION

Fraud and/or deception will not be allowed relative to 4-H exhibits. Fraud and/or deception being defined to include, but not limited to, the following:

1. **TAMPERING (ALTERING) AND/OR MISREPRESENTATION** relative to an animal's breeding, age, ownership, and/or method of preparation or completion; (this includes coloring that alters or misrepresents breed characteristics, pumping and filling).
2. **UNETHICAL FITTING OF ANIMAL EXHIBITS** considered as consisting of any substance or performance of surgical procedure, altering the animal's configuration and/or rendering its tissues unfit for human consumption at the time of exhibition or subsequent slaughter. Exceptions include hoof trimming; dehorning; removal of hair; manipulation of normally attached hair; treatments or surgical procedures applied to relieve pain and suffering or a sick or injured animal, providing such treatments do not render the animal's tissues unfit for human consumption.

DETERMINATION OF FRAUD AND DECEPTION

- The respective 4-H committee or superintendent, in consultation with the 4-H Youth Development Extension Educator, will determine if fraud and/or deception has occurred. Their decision will be final.
- Any suspect animals may be required to submit to examination as prescribed by the committee.
- If the committee determines that fraud and deception have occurred, the result will be immediate disqualification by the director in charge of that department,

PENALTY

Upon determination that fraud and/or deception has occurred prior to, during or after judging, the following penalties shall be imposed:

- The exhibit in question will be immediately disqualified. (Reference Determination of Fraud and Deception above.)
- The exhibit will not be allowed to be sold in the Livestock Auction. (In the case of an exhibit already sold at the 4-H auction, the exhibitor will be required to return all sale money in excess of market value to the 4-H sale committee. The money may be returned to the buyer or donated to the Fulton County 4-H Scholarship Fund). Note: Placings of other exhibits will not be adjusted as a result of the imposition of this penalty.
- Any and all premiums, trophies, and awards connected to the exhibit in question will be withdrawn and required to be returned.

DUE PROCESS

- The assessment of any or all penalties for fraud and/or deception, excepting immediate disqualification (reference Determination of Fraud and Deception above), shall follow the below listed process:
- The committee in charge of the department will determine which penalties to impose.
- The exhibitor will be notified in writing of the penalties imposed.
- Within 15 days of receiving written notification, the exhibitor may appeal the decision in writing to the Fulton County 4-H Council.
- A date will be set for a hearing by the Fulton County 4-H Council and the exhibitor will be notified in writing.

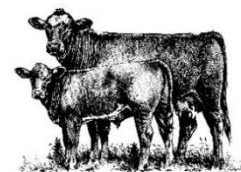

BEEF

<i>Saturday, March 5, 2022</i> <i>May 15, 2022</i>	<i>9:00-11:00 a.m.—Beef & Dairy Steer ID & Tag</i> <i>Deadline for Online Enrollment (Beef Steers, Dairy Steers, & Commercial Heifers)</i> <i>State Fair Beef Steer DNA Samples due</i>
<i>Saturday, May 7, 2022</i> <i>May 15, 2022</i>	<i>9:00-10:00 a.m.—Feeder Calf ID</i> <i>State Fair Registered Heifer DNA samples due</i> <i>Deadline to register Beef & Feeder Calf in 4-H Online</i> <i>Deadline to register online for State Fair for Beef and Feeder Calf</i> <i>Pen Cards are due</i>
<i>Coming Soon</i> <i>June 24, 2022</i>	<i>Deadline to Register all animals in FairEntry</i> <i>FULTON COUNTY 4-H FAIR</i>
<i>July 1, 2022</i> <i>July 9-16, 2022</i>	<i>11:00 a.m.-1:30 p.m.—Check-in/Weigh-in</i>
<i>Sunday, July 10, 2022</i>	<i>1:00 p.m.—Beef Show (includes Dairy Beef, Feeder Calves, & Mini 4-H)</i>
<i>Tuesday, July 11, 2022</i>	<i>5:00 p.m.—Supreme Master Showmanship</i>
<i>Thursday, July 14, 2022</i>	<i>10:00 p.m.—Release Horse & Pony and Livestock Exhibits not in the sale</i>
<i>Thursday, July 14, 2022</i>	<i>5:00 p.m.—Livestock Auction—Hudkins Arena</i>
<i>Friday, July 15, 2022</i>	<i>7:00 p.m.—Grand Champions Spotlight Sale—Hudkins Arena</i>
<i>Friday, July 15, 2022</i>	
<i>July 29-August 21, 2022</i>	<i>INDIANA STATE FAIR</i>

The Animal Record Sheet that includes the cost analysis is due at check in.
All Housing requests are due at the time of enrollment.

Any 4-H Exhibitor may show at State Fair. Registration forms are available on the Indiana State Fair Website:
<http://www.state.in.us/statefair/fair> Due date for these forms to be completed is **June 1st**.

**** See Additional Information on Page 142**

Read these rules carefully:

- A. All Aberdeen Angus, Chianina, Gelbvieh, Hereford, Limousin, Maine-Anjou, Red Poll, Salers, Santa Gertrudis, Shorthorn and Simmental Steers, shown in the respective breed shows at the State Fair, must be registered and must present valid registration certificates from their national registries. Check State fair Guidelines for more information on Market Steer Qualifications for the State Fair Show.
- B. Registered heifers show by breed as on registration papers—for example Sim Solution class or Maintainer class etc. (in addition to regular Simmental class and Maine Anjou class etc.)
- C. A beef member may show no more than six (6) steers and six (6) heifers in the beef project.
- D. All steers and market heifers, dairy-beef steers and commercial heifers will be identified by a county wide committee using a uniform ear tagging system at a central location along with RFID tag; at the same time all steers and market heifers will be weighed to take part in a rate of gain contest.
- E. False switches and use of artificial hair is prohibited. Only natural hair growing in the original location will be permitted. Anyone caught using artificial hair or false switches will forfeit ribbons and premiums.
- F. A calming agent used during fair week must be administered in the presence of the Department Head and 2 committee members. The 4-Her will be informed about drug withdrawal time and show rules. If any animal has been given a calming agent, that animal will not be allowed to show in showmanship classes. If a calming agent is used and it has a withdrawal period then that animal will not be eligible for sale.
- G. No stomach pumping or drenching with anything is allowed.
- H. No one is to use needles unless by a Licensed Veterinarian.
- I. No altering of original hair color.
- J. A calf must be dehorned for safety reasons. Scurs will be allowed. (Scur length is up to the discretion of the Beef Committee)
- K. Overhead fans are to face east.
- L. Housing requests will be checked by Beef Committee before final approval by Council.
- M. Grooming chutes and tack boxes can come in the Friday before the fair.
- N. **All animals** are subject to random spot checks throughout the summer.
- O. When choosing the top 5 heifers and the top 5 steers the reserve from each class will also be brought into the ring. If the judge chooses his first and second animal from class the 3rd place animal from that class will be brought in. This will continue until we have our top 5. For Heifers and Steers that have Breed Registries that

currently or in the future have multiple breed categories recognized there will be an overall Breed Champion awarded for that Breed, for both Heifers and Steers. The Overall Breed Champion for Heifers and Steers will represent that Breed in the Grand drive. Each Breed category will first have its designated class or classes with the champion being recognized. The Breed categories will then compete for the overall Breed Champion trophy, for both Heifers and Steers.

STEERS AND MARKET HEIFERS

For the 2022 Fair, all calves must be 2021 calves except for Senior Yearling Heifers which must be born between September 1, 2020 and December 31, 2020. All steers and market heifers will show by breeds or weight classes determined after all calves have been weighed. Steers will show in the breed if screening committee accepts the breed designated, no matter how many or few animals there are in the breed.

1. A steer that has passed the screeners and has been weighed-in may drop breed to crossbred if designated when it comes off trailer at check-in at fair.
2. Market heifers must be designated at weigh in. She will show by weight.

HEIFERS

3. Shown by breed as they are registered except for commercial heifers which will show by weight. All Commercial Heifers should be **2021** calves. A heifer not checked in at weigh-in must show as a registered heifer with appropriate papers, tattoos, and RFID tags must be done by enrollment deadline (May 15).

A. Junior Calf	January 1, 2022 to March 31, 2022
B. Winter Calf	November 1, 2021 to December 31, 2021
C. Senior Calf	September 1, 2021 to October 31, 2021
D. Late Summer Yearling	July 1, 2021, August 31, 2021
E. Early Summer Yearling	May 1, 2021 to June 30, 2021
F. Spring Yearling	March 1, 2021 to April 30, 2021
G. Junior Yearling	January 1, 2021 to February 29, 2021
H. Senior Yearling	September 1, 2020 to December 31, 2020

4. **County Bred and Born Class** – A steer, market heifer or commercial heifer bred/born in Fulton County and raised by a Fulton County 4-Her is eligible to be enrolled in this class on the Fulton County Bred and Born Steer and Heifer enrollment form. These forms are due at Beef Identification. Purebred heifers bred/born in Fulton County and raised by a Fulton County 4-Her are eligible to be enrolled in this class on the Fulton County Bred and Born Steer and Heifer enrollment. These forms are due by April 1.
5. If a 4-Her lives outside the county, but is a member of Fulton County 4-H, the calf can be home born and raised, or born within the boundaries of Fulton County and raised by the 4-Her. County born calves are to follow order of show. The top county born and raised calf in each class will be eligible to return for the champion selection.
6. **Cow/Calf Class** – Heifers that were enrolled and shown by the 4-H member in prior years will be eligible to return with their calf for the Cow/Calf class. They must have an RFID tag. A cow that wins champion 1 time is no longer eligible to show at the County Fair. Animals must be enrolled by May 15.
 - Calf at side. A heifer must be shown to be eligible to come back as a cow/calf pair.
 - She will be eligible for Cow/Calf as a two (first calf) or three-year-old (second calf.)
 - Two cow/calf exhibits are allowed per member and both are to be broke to lead.
 - Enrollment deadline is May 15. (These 4 animals are in addition to the 12 maximum.)
 - The show classes will be by breed, with the heifer and calf being shown in the same breed class as the heifer was the previous year.

- The cow/calf will be dismissed from the fairgrounds after the Beef Show, except for the supreme pair.
7. **Rate of Gain Class** – Awards will be given for the winner and reserve winner only (Not of each breed). All steers and market heifers are weighed at time of ear tagging, and are weighed again at time of entry at the fair to determine winners.
 8. **NEW—Slick Shear Class**—State Fair guidelines—Calf must be declared before the scale at check-in time at fair—goes in with crossbred division.

4-H Slick Steers, Market Lambs & Meat Goats Clipping/Shearing Info

4-H Indiana Slick Steers

The Indiana Slick Steer classes/division at the 2018 Indiana State Fair is different than what most people would typically think of when picturing Slick Steers. This is not the same as "Texas" style Slick Steers. Indiana Slick means: all steers must be clipped to hair length of less than $\frac{1}{4}$ of an inch from the knee on front legs and the hock on rear legs, up, and throughout the shoulders, front, body, top and hind-end. Indiana Slick Steers are allowed to have hair at the tail head, ears and belly line. Hair length will be inspected and measured at 4-H Steer check-in & Weigh-in. Please review the Indiana Slick Steer photo clipping demo below, areas circled in yellow are where hair may be any length and fully fitted for show.

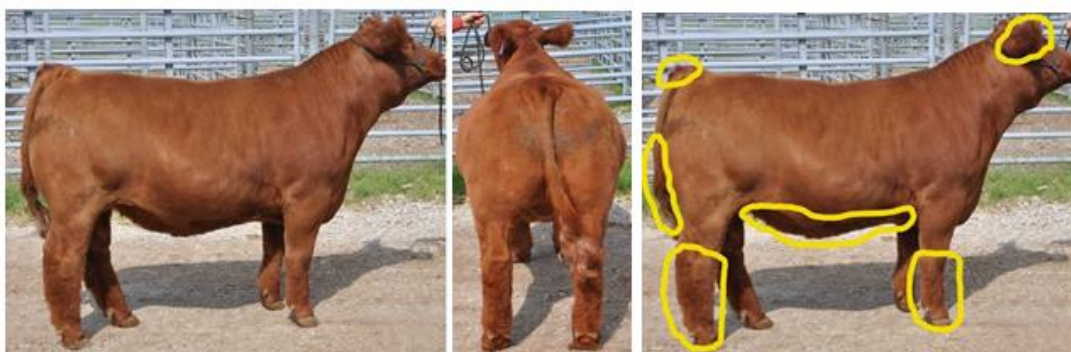

9. Steers must weigh a minimum of **800 lbs.** on Sunday to be sold in the sale.
10. Wood chips will be used for bedding of beef animals.
11. At requests of the 4-Her, female animals entered in the registered female division of the beef project can be checked at the farm for tattoos and registration identification by a member of the committee.
12. Early dismissal of breeding stock after the Beef show will be at the discretion of the Beef Department.
13. All calves are to stay in the barn after 11:00 p.m. No tie outs due to lack of room and not everyone can tie out.

**SEE GENERAL LIVESTOCK GUIDELINES SECTION BEGINNING ON PAGE 148.
ALSO CHECK OUT SECTIONS IV, V, & VI ON THE 4-H COUNCIL PAGE 20.**

14. At the time of 4-H Beef Identification (weighing, ear-tagging, etc.), a screening committee will be present. They will be responsible for screening all 4-H Beef Steers nominated as a breed steer. Those individuals with steers that get screened out of the breed for which they've been nominated will be notified immediately. A 4-Her may choose from the following two options:
 - A. Show the steer as a crossbred at the Fulton Co. 4-H Fair. **OR**
 - B. Disprove the decision of the screeners.
15. To disprove the decision of the screeners, the following procedure will be followed:
 - A. A supervised blood test is defined as one in which an Extension Educator and one beef committee member be present when blood test is taken.
 - B. Extension Educators will take possession of the blood test and deliver it to the lab.
 - C. Results of the blood test will be sent to the Extension Office and the family by the lab.
 - D. The blood test must be taken within 30 days after the family is notified of the screener's decision.

FEEDER CALF PROJECT

<p>Saturday, March 7, 2022 May 15, 2022</p>	<p>9:00-11:00 a.m.—Beef & Dairy Steer ID & Tag Deadline for Online Enrollment (Beef Steers, Dairy Steers, & Commercial Heifers) State Fair Beef Steer DNA Samples due</p>
<p>Saturday, May 7, 2022 May 15, 2022</p>	<p>9:00-10:00 a.m.—Feeder Calf ID State Fair Registered Heifer DNA samples due Deadline to register Beef & Feeder Calf in 4-H Online Deadline to register online for State Fair for Beef and Feeder Calf Pen Cards are due</p>
<p>Coming Soon June 24, 2022 July 1, 2022 July 9-16, 2022</p>	<p>11:00 a.m.-1:30 p.m.—Check-in/Weigh-in Deadline to Register all animals in FairEntry FULTON COUNTY 4-H FAIR</p>
<p>Sunday, July 10, 2022 Tuesday, July 12, 2022 Thursday, July 14, 2022 Thursday, July 14, 2022 Friday, July 15, 2022 Friday, July 15, 2022 July 29-August 21, 2022</p>	<p>1:00 p.m.—Beef Show (includes Dairy Beef, Feeder Calves, & Mini 4-H) 5:00 p.m.—Supreme Master Showmanship 10:00 p.m.—Release Horse & Pony and Livestock Exhibits not in the sale 5:00 p.m.—Livestock Auction—Hudkins Arena 7:00 p.m.—Grand Champions Spotlight Sale—Hudkins Arena INDIANA STATE FAIR</p>

1. All calves are to be born between January 1 and May 1 of current year.
2. They may be dairy or beef calves. All dairy calves must be steers and all beef calves may be either sex (steers or heifers.) There will be a dairy and a beef champion, but no Grand and Reserve Grand Champions.
3. The calves must be enrolled by May Feeder Calf ID Day. You may enroll and show 6 (Six) at the County Fair.
4. The calves must be clamped or castrated, dehorned, weaned and broke to lead.
5. Calves will check-in with other beef animals and remain at the Fair all week.
6. A Feeder calf can sell at the Livestock Auction as their Beef project.
7. Classes will be determined by check-in weight.
8. Animal identification day and time will be determined after March 1 project enrollment.
9. Feeder calf animals may be used in showmanship classes.
10. All Feeder calves must be ear tagged with RFID tags and County Tags.

**SEE GENERAL LIVESTOCK GUIDELINES SECTION BEGINNING ON PAGE 148.
ALSO CHECK OUT SECTIONS IV, V, & VI ON THE 4-H COUNCIL PAGE 20.**

Maximum weight on feeder calves is 700# at fair weigh-in for calves to compete for champion. Overweight calves will be allowed to show for exhibition only.

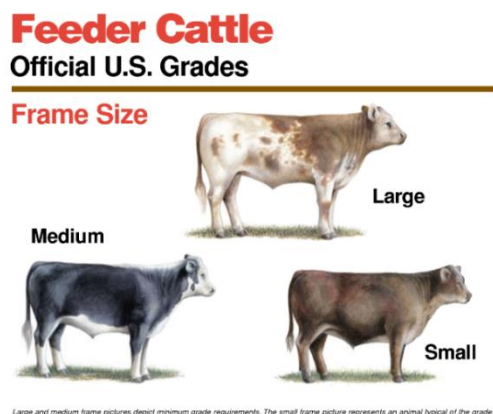

CATS



May 15, 2022

July 1, 2022

July 1, 2022

July 9-16, 2022

Friday, July 08, 2022

July 29-August 21, 2022

Deadline to register Cats in 4-H Online

Deadline to register Cats online for the State Fair

Deadline to register all animals in FairEntry

FULTON COUNTY 4-H FAIR

6:00 p.m.—Cat Show for Mini and Regular 4-H—Everett Smith Building

INDIANA STATE FAIR

Cats must have vaccination form completed before they can be brought to meetings and/or workshops.

Exhibit Requirements: In order to complete the 4-H Cat Project, you must do the following:

1. Exhibitor must be enrolled in the Cat Project.
2. Each member may show only his or her cat or the family cat.
3. To be eligible, the cat must be in possession of the 4-Her by **May 1**. All kittens must be born by **April 1** of the year it is shown.
4. For show, the cat may be either a purebred or household pet.
5. The cat must be fed and cared for by the 4-H member.
6. All cats are required to have had feline panleukopenia; feline rhinotracheitis; calcivirus; and test negative for and be vaccinated for feline leukemia. If a cat tests negative the first time and is vaccinated yearly for feline leukemia, then the test will not need to be repeated before each vaccination. All cats over 3 months of age must be vaccinated for rabies by a licensed, accredited veterinarian. Cats must be vaccinated within the last 12 months, but at least 2 weeks before the show. If cats do not have proof of inoculations on day of show, they will not be allowed to participate in the show. Cats must be dewormed or have a negative fecal exam within 6 months of exhibition.
7. **BRING PROPER HEALTH PAPERS WITH YOU.** (See Animal Health Requirements in Indiana for more information.)
8. Vaccination guidelines for Fulton County will match the State Fair rules.
9. **The Cat record sheet and Activity sheet must be submitted at the last cat meeting before the show or at the Cat show.**
10. Members in Division 3 or higher may show more than one cat. The cats must be shown in different classes.
11. For any 4-H member enrolled in the Cat Project, there will be a Costume Class, a Cage Decorating Class, and a Cat Toy Class. Toys may be scratching posts, catnip toys, balls, stuffed mice, etc.—use your imagination.
12. Cats should be classed according to their predominate characteristics (gender and coat length). The 4-H member is responsible for getting the cat in the correct classification.
13. The 4-H member must stay and present his or her cat for judging.
14. **The cat must be wearing either a Collar OR Harness AND Leash at ALL times;** this includes meetings where cats are in attendance. A cat carrier is required for travel and holding during the show.
15. The owner must take the cat home immediately following the show.
16. All 4-H cats must have their nails clipped. This is a safety factor for both member and judge.
17. If entering a cat at the show is not possible due to family allergies, condition of cat (including: injury or illness, pregnancy, death or in heat) or illness of member, or not being able to have a cat due to restrictions of residence the Cat project may be completed by preparing a notebook or a poster or a cat toy or decorating a carrier.

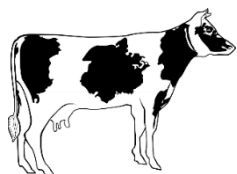

DAIRY

Dairy Animals now must have RFID tags

<i>May 15, 2022</i>	<i>Deadline to register Dairy in 4-H Online</i>
<i>May 15, 2022</i>	<i>DNA Samples must be returned to office if going to State Fair</i>
<i>Coming Soon</i>	<i>Deadline to register Dairy online for the State Fair</i>
<i>June 24, 2022</i>	<i>Pen Cards are due</i>
<i>July 1, 2022</i>	<i>Deadline to register all animals in FairEntry</i>
<i>July 9-16, 2022</i>	<i>FULTON COUNTY 4-H FAIR</i>
<i>Sunday, July 10, 2022</i>	<i>11:00 a.m.-1:30 p.m.—Check-in/Weigh-in</i>
<i>Monday, July 11, 2022</i>	<i>9:30 a.m.—Dairy Show (Mini 4-H Dairy followed by 4-H Dairy)—Hudkins Arena</i>
<i>Thursday, July 14, 2022</i>	<i>5:00 p.m.—Supreme Master Showmanship</i>
<i>Thursday, July 14, 2022</i>	<i>10:00 p.m.—Release Horse & Pony and Livestock Exhibits not in the sale</i>
<i>Friday, July 15, 2022</i>	<i>5:00 p.m.—Livestock Auction—Hudkins Arena</i>
<i>Friday, July 15, 2022</i>	<i>7:00 p.m.—Grand Champions Spotlight Sale—Hudkins Arena</i>
<i>July 29-August 21, 2022</i>	<i>INDIANA STATE FAIR</i>

In order to complete the Dairy Project, each member must turn in their Animal Record Sheet that includes the cost sheet at animal check-in. All dairy animals must be enrolled online by May 15. All housing requests are due at time of enrollment. Pen Cards are due June 24, 2022.

- All animals at time of enrollment must have an RFID tag. They will also need the ear tag number, tattoo in the ear, or registration number and/or dam's identification number.
- Any exhibitor may exhibit at the State Fair if properly enrolled and registered; contact Extension Office for more information. Fulton County has a dairy lease program for those not owning dairy animals or living on a farm using the Indiana State 4-H lease program rules.
- Dairy breeds include Ayrshire, Brown Swiss, Guernsey, Jersey, Holstein and Milking Shorthorn. All dairy animals (see above) must be listed dairy breeds of both sire and dam. NO crossbreds allowed. Any question concerning breed will be referred to dairy committee.
- Milking cows must be stalled **before 8:00 a.m. show day**. Milking cows and all other cattle will be entered in their respective classes by Sunday Check-in. All dry cows not milking will be required to be stalled by Sunday check-in. All papers will be checked at time of unloading. Milking cattle will be released after the show.
- Order of Show:**
 - Jr. Classes age by breed, followed by Jr. Champion
 - Sr. Classes age by breed, followed by Sr. Champion.
 - Junior and Senior Champions will compete for Grand Champion and Reserve within each breed.
 - ** Each breed must have an animal that has freshened prior to the show to have a Grand Champion.**
 - **Any animal that has freshened or in milk will show in a cow class.**
 - Showmanship**—All ages of showmanship will be same as County General Rules 16 and 17:
 - Beginner Showmanship
 - Junior Showmanship
 - Senior Showmanship
 - Master Showmanship – Senior winner will be included.
- Showmanship will be at the conclusion of the Grand Champions. Master Showmanship winner will be expected to participate in the Supreme Master Showmanship contest.
- A representative gallon of milk will be sold from each of the dairy breed Grand Champions.
- Any 4-H dairy member wanting to sell a dairy product (weighing at least 2 pounds) such as butter, cheese, etc. but not milk must participate in showmanship at this year's fair.
- Livestock will not be released till 10:00 p.m. on Thursday night. Removing any livestock before 10:00 p.m. without approval of the barn head will result in loss of completion points for that specific project and the 4-H member will not be allowed to sell anything in the auction. Animals may be released by the barn head if the animal is sick, the individual has received prior approval from the 4-H council to attend another show, or due to weather related conditions.

Dairy Class descriptions for 2022. County Fair:

Junior Heifer	Born March 1, 2022 to April 15, 2022
Winter Heifer	Born December 1, 2021 to February 28, 2022
Summer Heifer	Born June 1, 2021 to August 31, 2021
Spring Yearling	Born March 1, 2021 to May 31, 2021
Winter Yearling	Born December 1, 2020 to February 28, 2021
Fall Yearling	Born September 1, 2020 to November 30, 2020

Senior Age Classes

Junior 2-Year-Old Cow	Born March 1, 2020 to August 31, 2020
Senior 2-Year-Old Cow	Born September 1, 2020 to February 28, 2020
Junior 3-Year-Old Cow	Born March 1, 2019 to August 31, 2019
Senior 3-Year-Old Cow	Born September 1, 2018 to February 29, 2019
4-Year-Old Cow	Born September 1, 2017 to August 31, 2018
5-Year and Over	Born on or prior to August 31, 2017

DOG OBEDIENCE

<i>May 13, 2022</i>	<i>Deadline to register Dogs in 4-H Online</i>	
<i>July 1, 2022</i>	<i>Deadline to register Dogs online for the State</i>	
<i>July 1, 2022</i>	<i>Deadline to register all animals in FairEntry</i>	
<i>Thursday, July 7, 2022</i>	<i>6:00 p.m.—Agility—Hudkins Arena</i>	
<i>Saturday, July 9, 2022</i>	<i>8:00 a.m.—Obedience, Showmanship, & Rally—Hudkins Arena</i>	
<i>July 9-16, 2022</i>	<i>FULTON COUNTY 4-H FAIR</i>	
<i>July 29-August 21, 2022</i>	<i>INDIANA STATE FAIR</i>	

Manual requirements for completion: Complete Dog Knowledge Test

4-Hers must have their enrolled dog's completed 4-H vaccination form (current year) turned into their dog obedience leaders BEFORE their dog can attend training classes. (The dog must be vaccinated for rabies, distemper, leptospirosis, hepatitis, parvovirus and Bordetella (kennel cough), or as required by the state. Heartworm preventative is recommended. Vaccination forms will be available from 4-H dog leaders and the Extension Office. See Dog Requirements in the Animal Health Requirements in Indiana section at the end of the Summary Guide).

For exhibit: each 4-H member may participate in the dog obedience show on Saturday.

Any exhibitor may show at the State Fair, pre-registration is required. More information is available on the Indiana State Fair Website.

1. The 4-H member must feed, train and care for his/her own dog or family dog which must live at the residence of the 4-Her. Exceptions will be made for dogs involved in the leader dog for the blind program.
2. The dog may be any age over 6 months as of April 15.
3. The dog does not need to be purebred.
4. The dog may not attend training class or be exhibited showing any sign of any communicable disease (INCLUDING FLEAS AND TICKS).
5. Each dog must compete in the obedience portion of the 4-H dog show in order to compete in showmanship or agility competition.
6. Female dogs in heat during the fair, may be shown by special arrangement in obedience only. Female dogs in heat may not attend training classes, however 4-Hers may still attend classes. It is best to have your dog spayed or neutered if they are not breeding stock.
7. The exhibitor assumes all responsibility for his/her dog.
8. 4-H dogs should wear well-fitting chain slip collars in any obedience class. No tags are permitted on this collar. The leash may be of fabric or leather and shall be six feet in length. Leather leashes are recommended.
9. For safety purposes, it is strongly recommended that a 4-H handler and dog attend 6 dog obedience classes prior to the county fair dog show. However, 4-Hers will be more successful if more classes are attended.
10. Any aggressive dog may be dismissed from the project. (See the Indiana 4-H Aggressive Dog Policy)
11. 4-H members cannot show wolves or wolf hybrids because they do not meet state vaccination requirements.

OBEDIENCE JUDGING CLASSES OFFERED

Dogs and/or handlers with previous training will be evaluated by the Dog sponsoring committee to determine what class they will be entered in. A handler may skip to a higher class level if they wish to do more advanced exercises. If they show at this level, they cannot move back to a lower class with the same dog in subsequent years.

CLASS 1A (not repeatable) For 4-Hers with no previous formal dog training experience with a dog which has received no obedience training prior to October 1.

CLASS 1B (not repeatable with the same dog) For 4-Hers with previous dog training experience with a new, untrained dog, or for 4-hers with no experience whose dog has had training, or for 4-Hers and dogs with previous training experience including showing in 1A, or for 4-Hers with no experience whose dogs have had training which disqualifies them for 1A.

CLASS 2A (not repeatable with the same dog) For 4-Hers and dogs which have completed 1A or 1B.

CLASS 2B (may repeat until ready to move up) For 4-Hers and dogs which have completed 2A.

CLASS 3A (not repeatable with the same dog) For 4-hers and dogs which have mastered Class 2 work.

CLASS 3B (may repeat until ready to move up) For 4-Hers and dogs which have been in 3A, but are not ready for Class 4 work.

CLASS 4A (not repeatable with the same dog) For 4-Hers and dogs which have mastered Class 3 work.

CLASS 4B (may repeat until ready to move up) For 4-Hers and dogs which have been in 4A but are not ready for Class 5 work.

CLASS 5A (not repeatable with the same dog) For 4-Hers and dogs which have mastered Class 4 work.

CLASS 5B (may repeat until ready to move up) For 4-Hers and dogs which have been in 5A but are not ready for Class 6 work.

CLASS 6A (not repeatable with the same dog.) For 4-Hers and dogs which have mastered Class 5 work.

CLASS 6B (may repeat) For 4-Hers and dogs which have been in 6A.

VETERANS CLASS (repeatable) For 4-Hers whose dog is at least 7 years old or are physically challenged. The dog must have completed at least Class 2B in previous years. Dogs that are physically challenged must be accompanied by a letter from a veterinarian stating that the dog is unable to perform jumping and/or retrieving exercises. A dog may not be shown in any other obedience class once they have competed in the Veterans Class.

CLASS SERVICE DOG A (not repeatable) For 4-Hers with no previous service dog training experience. (Exercises are listed on scoresheet)

CLASS SERVICE DOG B (repeatable) For 4-Hers with previous service dog training experience. (Exercises are listed on scoresheet)

1A	Heel on Leash	40	1B	Heel on Leash	40
	Figure 8 on Leash	40		Figure 8 on Leash	40
	Sit for Exam on Leash	40		Stand for Exam on Leash	30
	Sit Stay on Leash—30 seconds	40		Recall on Leash	30
	Recall on Leash (no Finish)	40		Down Stay (Walk Around Ring)	30
				Sit Stay (Get Your Leash)	30
2A	Heel on Leash, Fig. 8 on Leash	40	2B	Heel on Leash, Fig. 8 on Leash	40
	Stand for Exam off Leash	30		Stand for Exam off Leash	30
	Heel Free	40		Heel Free	40
	Recall off Leash	30		Drop on Recall	30
	Sit Stay (Get Your Leash)	30		Sit Stay (Get Your Leash)	30
	Sit Stay 1 minute (group)	30		Sit Stay 1 minute (group)	30
	Down Stay 1 minute (group)			Down Stay 1 minute (group)	
3A	Heel Free & Figure 8	40	3B	Heel Free & Figure 8	40
	Stand for Exam off Leash	40		Stand for Exam off Leash	40
	Dumbbell Recall	40		Retrieve on Flat	40
	Drop on Recall	40		Drop on Recall	40
	Stand Stay (Get Your Leash)	40		Stand Stay (Get Your Leash)	40
4A	Heel Free & Figure 8	40	4B	Heel Free & Figure 8	40
	Retrieve on Flat	40		Retrieve on Flat	40
	Dumbbell Recall over High Jump	40		Retrieve over High Jump	40
	Recall over Broad Jump	40		Broad Jump	40
	Command Discrimination (Stand, sit, down)	40		Command Discrimination (stand, down, sit)	40
5A	Hand Signals (and voice)	45	5B	Hand Signals	45
	Directed Retrieve (2 gloves)	40		Directed Retrieve	40
	Retrieve over High Jump	45		Retrieve over High Jump	45
	Broad Jump	35		Broad Jump	35
	Moving Stand and Exam	35		Moving Stand and Exam	35
6A	Hand Signals	40	6B	Hand Signals	40
	Scent Discrimination (1 retrieve)	30		Scent Discrimination (2 retrieves)	60
	Directed Retrieve	30		Directed Retrieve	30
	Moving Stand and Exam	30		Moving Stand and Exam	30
	Go Out	30		Directed Jumping (2 jumps)	40
	Directed Jumping (1 jump)	40			
Veterans	Heel Free	40	4-H Dog Obedience Classes		
	Figure 8 off Leash	40			
	Stand for Exam off Leash	40			
	Recall off Leash	40			
	Stand Stay (Get Your Leash)	40			

SHOWMANSHIP CLASSES

NOVICE SHOWMANSHIP—For any 4-H exhibitor in their first year of dog showmanship.

JUNIOR SHOWMANSHIP— For any 4-H exhibitor who is in the 4th or 5th grade on January 1 of the current year. Once an exhibitor is the Junior showmanship winner, then he/she is only eligible to compete in Intermediate or Senior showmanship in subsequent years.

INTERMEDIATE SHOWMANSHIP- For any 4-H member in the 6th, 7th or 8th grade on January 1 of the current year. Once an exhibitor is the Intermediate showmanship winner, he/she is only eligible to compete in Senior showmanship in future years. Exception only for Junior winners.

SENIOR SHOWMANSHIP--For any 4-H member in the 9th grade or above on January 1 of the current year. Exceptions only for Intermediate winners. Once an exhibitor is the Senior showmanship winner, he/she is only eligible to compete in Master Showmanship in future years.

MASTER SHOWMANSHIP--Past Senior showmanship winners and current senior, intermediate, and junior winners.

AGILITY COMPETITION

The 4-H Dog Agility Program is an obstacle course based on guidelines from the American Kennel Club. Some modifications to the AKC rules have been made to provide a program suitable for 4-H handlers of all ages. Dogs showing in agility are also required to show in obedience at Level 1B or above and be 15 months of age by the day of the show. The dog must wear a buckle collar. The level of competition will be determined by the handler and their county leader based on the dog's ability and training. Scoring will be based on AKC rules, starting with 200 points and subtracting performance faults based on a set course time. Time faults for course time exceeding the set time will be deducted.

Judging Classes

- * **Beginning A** – 4-H member nor dog have previously participated in Agility. The course is run on a 6-foot leash.
- * **Beginning B** – 4-H member or dog has previously participated in Agility. The course is run off leash.

- * **Intermediate A** – 4-H member has not previously participated in Intermediate Agility in a previous year. The course is run off leash.
- * **Intermediate B** – 4-H member has participated in Intermediate Agility before, with current dog or a different dog in a previous year. The course is run off leash.

- * **Advanced A** – 4-H member has not previously participated in Advanced Agility. The course is run off leash.
- * **Advanced B** – 4-H member has participated in Advanced Agility before, with the current dog or a different dog in a previous year. The course is run off leash.

Each class will offer five divisions based on the dog's height at the withers.

- * **4 inches:** For dogs 11 inches and under at the withers
- * **8 inches:** For dogs 14 inches and under at the withers
- * **12 inches:** For dogs 18 inches and under at the withers
- * **16 inches:** For dogs 22 inches and under at the withers
- * **20 inches:** For dogs over 22 inches at the withers

Veteran Designation—Dogs 7 years and over may be entered as Agility Veterans and jump one height division lower than their actual height division.

For more details refer to the current Indiana 4-H Dog Agility Guidelines.



PURDUE COOPERATIVE EXTENSION SERVICE

College of Agriculture

Indiana 4-H Aggressive Dog Policy

The safety and well-being of 4-H members and volunteers is a primary concern with all Indiana 4-H Program opportunities. Families should err on the side of caution in selecting a dog for the 4-H member to exhibit. A dog that has a known history of aggression or biting is not appropriate for involvement in the 4-H Program. On occasion, the 4-H member may have difficulty managing their dog within the 4-H Program. The following guidance has been provided for the Indiana 4-H Dog Program as the owner/exhibitor of the dog bears responsibility for the dog's actions. In the subsequent policy, the term "4-H Dog Personnel" will include County 4-H Volunteers, County Extension Educators, State 4-H Staff and appropriate County and State Fair Directors.

A dog that bites a human or another dog at any 4-H Dog Event must be immediately removed from that event by the 4-H member and will subsequently be excused from the 4-H Program. The member should be directed by 4-H Dog Personnel on-site to remove the dog if the member does not do so willingly. If a determination is made by the 4-H Dog Personnel that a dog bit in self-defense, it may be allowed to remain at the 4-H Dog Event.

Dogs that display other signs of aggression, including but not limited to barking and standing ground, growling, lunging and snapping will be given one verbal warning. They will be removed from the event after the second violation at the same event. To be removed from a 4-H Dog Event, there must be two violations at the same event.

Any dog that is removed from a 4-H Dog Event due to aggressive behavior will be placed on probation for 2 weeks. Written notification of the probation will be given to the 4-H member. The 2-week period will start upon written notification to the 4-H member. While on probation, the 4-H Dog Personnel and the 4-H member and parents will work together to determine the best course of action for the dog. This may include (but is not limited to) working individually with the dog and 4-H member, asking the 4-H member to use a different dog or having the 4-H member attend events without their dog. At the end of the designated probation period, 4-H Dog Personnel will make a determination regarding the dog's return to 4-H Dog Events.

Dogs that are removed from a 4-H Dog Event twice will be immediately excused from the 4-H program and will not be allowed to re-enter. Excusing a dog from the 4-H Program is rare but could be necessary for the safety of 4-H members, volunteers and other participating dogs. Should a dog be excused from the program, it must be remembered that the action is against the dog and not the 4-H member. 4-H Dog Personnel should look at many solutions and encourage the 4-H member to attend classes without their dog while training it at home or potentially bringing another dog to 4-H events. 4-H members will always be welcome in every other part of the dog project.

In the event that a dog is removed from a 4-H Dog Event or excused from the 4-H Program, 4-H Dog Personnel should report such to the State 4-H Office so that the information is available to all county 4-H dog programs and the Indiana State Fair.



Indiana 4-H Youth Development Program

Agricultural Administration Building, Room 104 • 615 W. State St. • West Lafayette, IN 47907-2053 •
 (765) 494-8422 • FAX: (765) 494-5876 • www.extension.purdue.edu/4h
 Purdue University, Indiana Counties and U.S. Department of Agriculture Cooperating
 An equal access/equal opportunity/affirmative action university

GOATS



April 29, 2022
 Saturday, May 7, 2022
 May 15, 2022
 May 15, 2022
 Coming Soon
 June 24, 2022
 July 1, 2022
 July 9-16, 2022
 Sunday, July 10, 2022
 Thursday, July 14, 2022
 Thursday, July 14, 2022
 Thursday, July 14, 2022
 Friday, July 15, 2022
 Friday, July 15, 2022
 July 29-August 21, 2022

Goat ID Worksheet, Housing Request due in office
 9:30-10:30 a.m.—Goat ID Weigh-in /Tag Date
 DNA Samples must be returned to office if going to State Fair
 Deadline to register Goats in 4-H Online
 Deadline to register Goats for the State Fair
 Pen Cards are due
 Deadline to register all animals in FairEntry
FULTON COUNTY 4-H FAIR
 4:00-5:00 p.m.—Check-in/Weigh-in (Dairy, Boer, Pygmy, & Market Goats)
 8:30 a.m.—Goat Show (includes Dairy, Boer, Pygmy, Market & Mini 4-H)
 5:00 p.m.—Supreme Master Showmanship
 10:00 p.m.—Release Horse & Pony and Livestock Exhibits not in the sale
 5:00 p.m.—Livestock Auction—Hudkins Arena
 7:00 p.m.—Grand Champions Spotlight Sale—Hudkins Arena
INDIANA STATE FAIR

The STATE ENROLLMENT IS DUE ONLINE AT GOAT ID—May 16, 2022

You must Include Premise ID number on enrollment.

- **ANY EXHIBITOR MAY SHOW AT STATE FAIR;** State Fair livestock entries are being made on-line and the due date will be determined by State Fair in May or June: Go to www.indianastatefair.com and then go to Competitions and Contests listed at the top of the page. State fair catalogs are also available online.
- **ALL HOUSING REQUESTS ARE DUE AT TIME OF ENROLLMENT.**
- **IN ORDER TO COMPLETE THE GOAT PROJECT:** All members must turn in a completed record sheet and complete required activities for their division at check-in time.
- **Your 4-H Fair Pen Cards** must be complete and readable with your animal's information. The animal's tattoo or ear tag number as well as their birthdate **MUST BE INCLUDED AND MATCH your enrollment form or your animal is ineligible to show or be brought to the fair.**

STATE ID Requirements:

Meat Goat Wethers	840 RFID Tag and 5-digit County Tag and DNA Hair Sample
Market Goat Wethers, Market Goat Does (Wether Dams)	840 RFID Tag and 5-digit County Tag and DNA Hair Sample
Boer Goat Females, Registered	Breed Registry Tattoo and DNA Hair Sample
Dairy Goat Females, Registered	Breed Registry Tattoo
Dairy Goat Wethers	5-digit County Tag or Tattoo
Pygmy Goats, Registered	Breed Registry Tattoo or Microchip that matches registration paper
Pygmy Goats, Unregistered	Official USDA Scrapie Tag or Official Scrapie Tattoo

1. In the event of conflict of general rules, the goat committee and the 4-H Council will govern.
2. Members will feed and care for at least one goat and may show no more than fifteen (15).
3. Members may not show more than 3 goats in any given class. Members may show up to 2 pairs of goats in the dam and daughter class.
4. Goats may be of grade or registered stock.
5. Exhibiting at least one or more of the project animals and a completed record sheet will fulfill completion requirements. However, if the 4-Her's animal (s) doesn't make it to the fair a completed record sheet will complete the project. (The record sheet should be submitted no later than Goat check-in.)
6. Project animals must be in possession of the 4-H member by Goat ID.
7. Each goat that is enrolled **must be** permanently tattooed **or** ear tagged or have a microchip *at* the time of enrollment and legible by check-in committee. Tattoos and ear tag numbers must be same as on online enrollment. **Freshly tattooed animals will be sent home. This rule will be strictly enforced.** Microchips will be permitted as a means of

- animal identification. It is the responsibility of the 4-H member to provide a microchip reader at check-in.
8. For ALL COUNTY meat classes, animals will have the 5-digit county tag or tattoo.
 9. Registration numbers, tattoos, birth dates and animal names must be exactly the same on the online enrollment as they appear on the animal's registration paper.
 10. All Dairy Goats must be polled or dehorned and healed; scurs must not exceed 2 inches from the front side of the horn.
 11. Market goats, Boer does and pygmy does will be permitted to show with horns.
 12. No bucks or hermaphrodites will be exhibited at the 4-H fair.
 13. 4-Her is responsible to make sure goat stays within assigned pen.
 14. All milking does must be milked twice daily while at the fair.
 15. **All milking does must be milked out between 8:00 p.m. and 8:30 p.m. the night before the show and must be checked by a committee member or department head. Any animal not milked out within the specified time will be disqualified from showing in milking goat classes. In the event that a member is unable to milk his or her goat during this time he or she must have someone else designated.**
 16. Grand Champion will be eligible to sell 1 qt. of goat milk in 4-H Auction. However, if 4-Her sells in 4-H auction that animal is no longer eligible to show at the Indiana State Fair.
 17. Four project committee members will be responsible for checking in goats. All GOATS will be checked in at the Goat Barn and between 4:00 – 5:00 p.m. All market goats will be weighed in at this time, also. Any animals in barn before check-in without department head approval will be sent home. Goat Committee members will be allowed to check in 1-2 hours prior to check-in, with approval of department head.
 18. 4-H member must furnish sawdust or wood shavings for bedding for goats. All pens must have one bale of sawdust per pen by 6:00 pm on Sunday of check in. **NO STRAW ALLOWED IN PENS!**
 19. No Angora goats can be shown.
 20. A. All Dairy goats must be clipped slick-shorn with-in 2 weeks prior to check in except junior kids.
B. Boer does are not required to be clipped slick-shorn.
C. All Market Goats must be clipped slick-shorn within 2 weeks prior to check-in.
D. Pygmy must be trimmed, unless a market animal.
E. Body clipping will not be permitted during fair week. Any dairy or market animal that is not clipped slick-shorn within 2 weeks prior to check-in or is body clipped during fair week will be sent home. Trimming, i.e. ears, hoofs, udders, etc. will be permitted.
 21. **All market goats** are to be born between September 1 of previous year and May 1 of current year. All will be judged on meat characteristics.
 22. All male goats are to be banded or castrated (No Clamping) by May 1.
 23. Ear tagging and weigh-in day will be announced. Weigh-in is also for Rate of Gain.
 24. 4-H members are responsible for getting animals to the show ring.
 25. All 4-Hers may show in any color shirt and long pants, below the knee length skirt or below the knee length
 26. The 7 ADGA (American Dairy Goat Association) recognized dairy breeds only, may be shown at the fair. The breeds are as follows: Alpine, Toggenburg, LaMancha, Oberhasli, Nubian, Saanen, and Recorded Grade. Recorded Grade is any combination of the other six ADGA breeds. This only applies to does and wethers. Nigerian Dwarf Goats will show in the dairy goat classes.
 27. Department Head can request that pens be cleaned.
 28. When giving goat product or medication to animal by dose or hypodermic syringe Department Head must be notified and 3 committee members present AND given by a licensed veterinarian.
 29. All pens must be cleaned out before 9:00 p.m. on Saturday or committee will charge \$20.00 per pen fee to be cleaned.
 30. The judges' decision is final.
 31. **DAIRY EXHIBIT CLASSES**
 Junior Kids - born after April 1, current year
 Intermediate Kids - born March 1 - 31, current year
 Senior Kids - born January 1 to February 28, current year
 Junior Yearlings - under 1 year and born before January 1 of current year
 Senior Yearling - 1 year and under 2, never fresh
 Doe - 1 year and under 2, milking
 Doe - 2 and under 3, milking
 Doe - 3 and under 5, milking
 Doe - 5 and over, milking
 Dam and Daughter Class - May show two pairs. Each pair consists of a dam and daughter.

32. MARKET GOAT CLASSES

- ALL market goats born between September 1 of previous year and May 1 of current year.
- Does may be shown in this class and sold in livestock sale. These does must be weighed in and ear tagged. Does in market class may not be shown in Breeding classes.
- Market goats that may be shown at the State Fair will need to have a Retinal Image Scan at Goat ID.
- A 4-HER MAY SHOW A MAXIMUM OF THREE (3) MARKET GOATS.
- Weight classes will be determined after weigh in at the fair.
- There will be separate classes for dairy and boer/pygmy wethers, but they will show together for an overall Grand and Reserve Grand Champion Market Wether
- The market goat class will be judged on meat characteristics.
- Classes will be determined by goat committee after check-in at county fair.
- All market goats will be identified with 1 five-digit ear tag and 1 RFID tag.
- Decision of committee is final.
- Market pygmy goats may show either as a Market animal against the Boer Wethers or as a pet in the Pygmy classes but not both. Market Pygmy goats must be weighed in at May weigh-in.

33. BOER GOAT CLASSES - Boer and market goats may show with horns.

- Class 1 Does under 3 months of age (Born April 16, 2022-July 16, 2022)
- Class 2 Does 3 months old to under 6 months of age (Born January 16-April 16, 2022)
- Class 3 Does 6 months old to under 9 months of age (Born October 16, 2021-January 16, 2022)
- Class 4 Does 9 months old to under 12 months of age (Born July 16, 2021 October 16, 2021)
- Champion & Reserve Champion Boer Junior Doe
- Class 6 Does 12 months old to under 16 months of age (Born March 16, 2021-July 16, 2021)
- Class 7 Does 16 months old to under 20 months of age (Born November 16, 2020-March 16, 2021)
- Class 8 Does 20 months old to under 24 months of age (Born July 16, 2020-November 16, 2020)
- Yearling Boer Doe Champion and Reserve Champion
- Class 10 Does 24 months old to under 36 months of age (Born July 16, 2019-July 16, 2020)
- Class 11 – Does 36 months old and older (Born Before July 16, 2019)
- Senior Boer Doe Champion and Reserve Champion
- Class 13 All Champion and Reserve Champion come back in for Grand and Reserve Grand Champion.

34. PYGMY GOAT CLASSES

- Class 1 Does under 3 months of age (Born April 16, 2022-July 16, 2022)
- Class 2 Does 3 months old to under 6 months of age (Born January 16-April 16, 2022)
- Class 3 Does 6 months old to under 9 months of age (Born October 16, 2021-January 16, 2022)
- Class 4 Does 9 months old to under 12 months of age (Born July 16, 2021 October 16, 2021)
- Champion & Reserve Champion Boer Junior Doe
- Class 6 Does 12 months old to under 16 months of age (Born March 16, 2021- July 16, 2021)
- Class 7 Does 16 months old to under 20 months of age (Born November 16, 2020-March 16, 2021)
- Class 8 Does 20 months old to under 24 months of age (Born July 16, 2020-November 16, 2020)
- Yearling Pygmy Doe Champion and Reserve Champion
- Class 10 Does 24 months old to under 36 months of age (Born July 16, 2019-July 16, 2020)
- Class 11 – Does 36 months old and older (Born Before July 16, 2019)
- Senior Pygmy Doe Champion and Reserve Champion
- Class 13 All Champion and Reserve Champion come back in for Grand and Reserve Grand Champion.

35. PYGMY PET CLASS

FULTON COUNTY 4-H GOAT SHOW

Thursday, July 14, 2022—8:30 a.m.

Show Order:

Mini 4-H Goat show
Showmanship (beginner, junior, intermediate, senior)
Dairy Does
Dairy Dam and Daughter
Dairy Market
Boer Market

****30-minute Lunch Break****

Pygmy
Pygmy Dam and Daughter
Boer Breeding does
Boer Breeding Dam and Daughter
Master Showmanship
Costume Class

Showmanship: Showmanship classes and grades:

Beginner: 3rd, 4th
Junior: 5th and 6th
Intermediate: 7th and 8th
Senior: 9th, 10th, 11th and 12th
Master: Any Previous Senior Winners

HORSE AND PONY



April 1, 2022

May 1, 2022

May 1, 2021

May 13, 2022

June 24, 2022

July 1, 2022

Coming Soon

July 9-16, 2022

Sunday, July 10, 2022

Monday, July 11, 2022

Monday, July 11, 2022

Tuesday, July 12, 2022

Tuesday, July 12, 2022

Wednesday, July 13, 2022

Thursday, July 14, 2022

Thursday, July 14, 2022

July 29-August 21, 2022

Lease Agreements due

Horse online identification forms AND pictures are due

Animal Location forms are due—must be completed by every member

Deadline to register Horse & Pony in 4-H Online

Pen Cards are due

Deadline to register all animals in FairEntry

Deadline to register Horse & Pony online for the State Fair

FULTON COUNTY 4-H FAIR

1:00-6:00 p.m.—Horse & Pony Check-in

8:30 a.m.—Showmanship & Halter Classes followed by *Trail Class*

6:30 p.m.—Equitation Classes

4:00 p.m.—Western Performance

10:00 a.m.—4-H Horse & Pony Extreme Challenge--formerly called Trail Ride

4:00 p.m.—4-H Costume Class and Mini 4-H Show

5:00 p.m.—Grand Entry, Awards, Fun Show

10:00 p.m.—Release Horse & Pony

INDIANA STATE FAIR

Horses and Ponies may be released on Thursday AFTER 10 p.m. There are no exceptions to this Council rule. TRUCKS OR TRAILERS MAY BE ON DRIVES EAST AND WEST OF BARN UNTIL SUCH TIME. This is to be a safe area with no vehicle traffic. All Animals must be out by NOON ON FRIDAY. ALL STALLS MUST BE STRIPPED AND CHECKED BY AN ADVISORY MEMBER BY NOON ON FRIDAY.

- 4-H MEMBER ONLINE ENROLLMENT AND \$15.00 State Program Fee IS DUE BETWEEN 10/1/21 AND 1/15/22. Online assistance at the Extension Office or Horse & Pony Roundup Meeting is available. The \$15 enrollment fee can be submitted by credit card online or by check payable to Purdue CES at the Extension Office.
 - TO COMPLETE THE HORSE AND PONY PROJECT, EACH MEMBER WILL COMPLETE and turn in cost analysis sheet.
 - TO PARTICIPATE IN THE FAIR FUN SHOW 4-HERS WILL ATTEND THREE HORSE AND PONY MEETINGS, 2 HORSE AND PONY WORKSHOPS, AND A DEMONSTRATION.
1. **All animals must be identified with a picture in 4-H Online by the May 15th deadline in order to be shown at the fair.**
 2. A 4-H member may enter and show in as many classes as he/she chooses but one of these must be halter to complete. Exception: Therapeutic Riding would fulfill completion requirements.
 3. A 4-H member may show no more than a total of 3 horses and each horse must be shown at halter to be eligible to show in performance class. Therapeutic Riding does not require a Halter Class.
 4. All animals must be sound and healthy, vaccinated (Eastern & Western Encephalitis, Rhino, Tetanus, Influenza, and Rabies are mandatory (Potomac and West Nile Vaccination recommended) and turn in vaccination certificate papers by **May 1**. Any questionable animal may be removed by a licensed veterinarian or advisory committee in the absence of a veterinarian. Coggins is NOT needed for State Fair or Fulton County. All animals, including Mini's animals, brought to fairgrounds must be vaccinated.
 5. Stallions are ineligible to show except weanlings.
 6. Age on January 1st shall be considered the birthday of all animals.
 7. Animals must be in the 4-H member's possession and cost analysis started by May 1. All horses are to be body scored by Vet at time of vaccination and meet the same criteria upon arrival at Fair. Any questionable horses may be rescored at check-in by leaders. All judges have the authority to remove animals scoring poorly.
 8. No animal substitutions after **the May 15th deadline.**
 9. Any animals exhibited must be shown and owned by the 4-H member or shown and owned jointly with member's father, mother, brother, sister, grandparent, aunt, uncle, or legal guardian. Showing of leased animals falls under the same rules, with the approval of the Horse and Pony Advisory Committee and the Extension Educator by May 1.

10. Cost analysis sheets are to be completed and handed in by the June 4-H meeting in order to assure that their stalls will be unlocked at the time of their Sunday arrival.
11. A 4-H member must show his/her own animal at halter unless injury, illness or multiple animals showing in the same class by that member. In case of injury, illness or multiple animals, the 4-H member may have the animal shown by another Fulton County 4-H member with the approval of the 4-H Horse and Pony Advisory Committee. Pre-existing conditions need to be approved at least 48 hours prior to the show. Other situations will be handled as needed. In order to accommodate a child with a disability, a 4-H member with special needs will be allowed one helper and one handler with second rope attached to the animal.
12. 4-H Exhibitors are not to ride their animals within the barns. Animals should not be ridden by anyone other than 4-H Horse and Pony members, immediate family, advisory committee and leaders. No trainers or instructors may ride during fair. On Monday and Tuesday animals may be ridden, lunged, and/or driven by the member who has enrolled the horse as their project only. Failure to comply with this rule may result in the disqualification of the horse to show at the fair. No trainers or instructors may ride.
13. 4-H Exhibitors must wear their assigned exhibit number in show ring on their back, back of carts or both sides of saddle. Those not meeting requirements may not be judged.
14. Bosal and snaffle bits are permitted only on animals 5 years and under.
15. When a curb chain is used, it must be of the flat curb style and be at least 1/2 inch wide.
16. Hackamore, draw-reins, martingales or tie-downs are not allowed, except in contesting classes, working hunter, color guard or jumper classes.

Consult your 4-H Rulebook for other rules related to tack and attire.

17. Each 4-H Horse and Pony member must fill out **COMPLETELY** the State 4-H Horse and Pony identification Form **ONLINE** by **May 1**. A **color** photo showing all 4 feet and the face of the horse must be submitted **ONLINE**. Substitutions with pictures must be approved and submitted by **May 15**. **Failure to complete Horse ID form will result in forfeiture of State Fair Entry and County Fair Show.**
18. Interpretation of 4-H Beginner, Junior, and Senior grades for showmanship and equitation as of January 1, current year:
 - (a) Beginner – First year Member (in Horse and Pony Project), any grade—English, Western, Hunter. Not eligible for any other showmanship Classes.
 - (b) Junior Div. – 3rd, 4th, 5th, 6th, and 7th grades
 - (c) Senior Div. – 8th, 9th, 10th, 11th, and 12th grades
 - (d) Master – First place winners of Junior and Senior classes in Saddle Type, Western and Hunter showmanship.
19. All entries must be entered in appropriate showmanship classes and will be scored accordingly by the judge.

DEFINITION OF BREED TYPES:

 - **Stock Type**—Muscular build, stockier body. Typical breeds of stock horses are American Quarter Horse, Appaloosa, and Paint.
 - **Hunter Type**—Longer, leaner body build, smooth muscle. Can be mixed breeds.
 - **Saddle Type**—More refined, lighter bones and muscling. Typical breeds of saddle type horses are Saddlebred, Morgan, Arabian, Tennessee Walker and Racking Horse.
20. The use of drugs is prohibited. Animals may be checked at random for conformance with this rule. Any protest must be submitted in writing and laboratory fees must be paid by the protestor. Refer to page 7, number 8 of the Indiana 4-H Horse and Pony Handbook.
21. All 4-H members are required to wear a properly fitted ASTM or SEI standard F1163 (or above) certified Equestrian helmet whenever mounted, or driving at a 4-H horse and pony event, show or activity. The 4-H member is responsible to see that this specified headgear is properly fitted with the approved harness fastened in place whenever mounted. Original tags **MUST BE PRESENT** in all approved helmets. This policy will be in effect beginning with the 2003 program year and applies to all County, Area, and State 4-H events, shows and activities.
22. All 4-Hers are required to **keep stalls and aisles** clean—bring own suitable cleaning equipment. A committee will check stalls daily. Manure must be piled in designated areas. If stalls do not pass inspections, a warning will be given the first time. A second time will result in loss of fun show privileges. A Herdsmanship Award will be presented during the achievement banquet. Members are encouraged to decorate their stalls. Awards will be given for the best decorated stalls. Any extension cords used must be grounded with three prongs.

23. Entries are due to the **State Fair Office** online by **July 1st**.
24. All stalls must be bedded with either sawdust or shavings.
25. Ring courtesy dictates that exhibitors must maintain a safe distance between animals in halter and performance classes. Any animal that is considered to be a kicker by the leaders may be asked to place a red ribbon in the tail. Optional: A white ribbon may be used in the tail to signal an impaired horse or rider. A green ribbon may be used in the tail to signal an inexperienced horse or rider.
26. Animals under 40" in height shall not be ridden at 4-H events. Weanlings, yearlings and two-year-old animals must be shown as height of dam, except if height exceeds that of the dam. Animals 56" & under, under 6 years of age, must be measured by a State Horse & Pony certified Measurer of the Fulton County 4-H Horse and Pony Advisory Committee. Animals 56" & under, over 6 years must have an initial measurement. Animals may be measured by the show committee. The show committee may measure at random, one time only, any animal of questionable height. The Indiana State Fair 4-H show committee considers animals 56 inches and under to be ponies and animals over 56 inches to be horses.
27. Each gaited horse shown in pleasure or horsemanship/equitation must select to show in either gaited or stock type.

CLASSES

SHOWMANSHIP – 4-H MEMBERS MAY SHOW ANIMAL IN EACH DIVISION (Hunter Type, Saddle Type, and Western). Refer to rule #19, definition of breed types.

HALTER CLASSES – 4-H MEMBERS MAY ONLY SHOW ANIMAL IN SADDLE TYPE, HUNTER, OR WESTERN DIVISION IN HALTER. Refer to rule #19, definition of breed types.

MONDAY AT 8:30 A.M.

THE FOLLOWING CLASSES WILL BEGIN ON MONDAY AT 8:30 AM.

SHOWMANSHIP — HUNTER TYPE

1. Senior grades 8th, 9th, 10th, 11th & 12th
2. Junior— grades 3rd, 4th, 5th, 6th, & 7th

HALTER

3. Halter, Special Needs Exhibitor, All types and Sizes.

HALTER — ENGLISH TYPE

4. English Type 56” & under, all ages, mares, colts, and geldings.
5. English Type Mare, over 56”, all ages
6. English Type Mare & Foal, all sizes (No Champion recognized. Foal may be shown in additional appropriate class.)
7. English Type Gelding over 56”, all ages

10 Minute Break

SHOWMANSHIP — SADDLE TYPE

8. Senior, grades 8th, 9th, 10th, 11th, and 12th
9. Junior, grades 3rd, 4th, 5th, 6th, and 7th all sizes

MASTER SHOWMANSHIP

10. First and second place winners of Junior and Senior classes in Saddle Type, Hunter, and Western Showmanship classes.

HALTER-WESTERN TYPE

11. Western Type Mare, 56" & under, all ages
12. Western Type, over 56", mare, all ages
13. Mare & Foal, Western type, all sizes (No champion recognized.) Foal may be shown in additional appropriate class.)
14. Western Type Colt or Gelding, 56” & under, all ages
15. Western Type Gelding, over 56", all ages

***GRAND CHAMPION HALTER**

- 22A. Grand Champion Mare Over 56 inches (all 1st place over 56 inch mares)
- 22B. Grand Champion Gelding Over 56 inches (all 1st place over 56 inch geldings)
- 22C. Grand Champion Under 56 inches Pony (all 1st place under 56 inch and under mares and geldings)

TRAIL CLASS – Senior and Junior Division 1 Hour after Halter classes are finished

16. Senior Division, grades 8 - 12, all sizes
17. Junior Division, grades 3 - 7, all sizes

MONDAY AT 6:30 P.M.

EQUITATION – THE FOLLOWING CLASSES ARE SHOWN ON MONDAY, 6:30 P.M.

These are State Fair classes:

DO NOT ENTER THESE CLASSES IF YOU ARE SHOWING IN A WALK-TROT CLASS.

15 Minute Break

18. Cross Rails Only, all ages, all sizes
19. Hunter Hack, 56" & under – Junior and Senior
20. Hunter Hack, over 56" – Junior and Senior
21. Pleasure Driving—Senior Division
22. Pleasure Driving—Junior Division
23. Hunt Seat Equitation – Senior Division- all sizes
24. Hunt Seat Equitation – Junior Division – all sizes
25. Hunt Seat Pleasure – Senior Division – all sizes
26. Hunt Seat Pleasure—Junior Division – all sizes
27. Gaited and Saddle Type Equitation—all sizes, all ages
28. Gaited and Saddle Type Pleasure—all sizes, all ages

***15 Minute Break ***

DO NOT ENTER THESE CLASSES IF YOU ARE SHOWING IN A WALK-TROT CLASS.

WALK TROT CLASSES ARE NOT ELIGIBLE FOR CONTESTING CLASSES OTHER THAN #65, #66, #69.

29. Keyhole Race, 56" & under- Senior Division, grades 8 –12
30. Keyhole Race, 56" & under – Junior Division, grades 3 – 7
31. Keyhole Race, over 56"-- Senior Division, grades 8 – 12
32. Keyhole Race, over 56" – Junior Division, grades 3 – 7
33. Speed and Action, 56" & under – Senior Division, grades 8 – 12
34. Speed and Action, 56" & under – Junior Division, grades 3 – 7
35. Speed and Action, over 56" – Senior Division, grades 8 – 12
36. Speed and Action, over 56" – Junior Division, grades 3 – 7

TUESDAY AT 4:00 P.M.

THE FOLLOWING CLASSES ARE SHOWN ON TUESDAY BEGINNING AT 4:00 P.M. **WALK TROT PARTICIPANTS ARE INELIGIBLE FOR CANTER CLASSES**

EQUESTRIAN CLASSES

37. Assisted Lead Line Equitation, any seat, (Challenged riders, all ages, may only ride in class #41 & #46)
38. Assisted Lead Line Pleasure, any seat, (Challenged Riders, all ages, may only ride in class #40 & #46)
39. Unassisted Walk/Trot Equitation, any seat (Challenged Riders, all ages, may only ride in class #43 & #47)
40. Unassisted Walk/Trot Pleasure, any seat (Challenged Riders, all ages May only ride in class #42 & #47)
41. Walk/Trot Equitation, any seat—grades 3 & 4 (May only ride in class #45 & #59)
42. Walk/Trot Pleasure, any seat—grades 3 and 4, (May only ride in class #44 & #59)
43. Assisted Lead Line Barrels, (Challenged rider, all ages. May only ride in class #40 & #41)
44. Unassisted Barrels, (Challenged rider, all ages. May only ride in class #40 & #41)

HORSEMANSHIP—STOCK SEAT

DO NOT ENTER THESE CLASSES IF YOU ARE SHOWING IN A WALK-TROT CLASS.

45. Western Horsemanship, all sizes—Senior Division, grades 8th, 9th, 10th, 11th, and 12th
46. Western Horsemanship, all sizes—Junior Division, grades 3rd, 4th, 5th, 6th, and 7th
47. Gaited and Saddle Type Western Pleasure, all ages, all sizes
48. Gaited and Saddle Type Western Horsemanship—all sizes, all ages
49. Western Pleasure, 56" & under—Senior Division, grades 8-12
50. Western Pleasure, 56" & under—Junior Division, grades 3-7
51. Western Pleasure, over 56"—Senior Division, grades 8-12
52. Western Pleasure, over 56"—Junior Division, grades 3-7
53. Bit Reining, (4-H Pattern #2)—Junior & Senior Division, all grades and sizes
54. Western Riding (4-H Pattern)—Senior Division, grades 8-12
55. Western Riding (4-H Pattern)—Junior Division, grades 3-7

Contesting horses will be brought to the arena in a controlled manner as determined by the judge before beginning the pattern. Assistance may be given by one (1) person of contestant's choice (not show personnel.) Any changes in this procedure will be announced before the class. Failure to enter or leave the arena in a controlled manner will result in disqualifications, at the discretion of the judge. Dismount before leaving the arena. Running or galloping into the arena is an automatic disqualification, at the discretion of the judge.

DO NOT ENTER CLASSES #57-#68 IF YOU ARE SHOWING IN A WALK-TROT CLASS.

56. Walk/Trot Barrels grades 3 and 4 (May only ride in class #44 & #45)
57. Flag Race, 56" & under—Senior Division, grades 8-12
58. Flag Race, 56" & under—Junior Division, grades 3-7
59. Flag Race, over 56"—Senior Division, grades 8-12
60. Flag Race, over 56"—Junior Division, grade 3-7
61. Barrel Race, 56" & under—Senior Division, grades 8-12
62. Barrel Race, 56" & under—Junior Division, grades 3-7
63. Barrel Race, over 56"—Senior Division, grades 8-12
64. Barrel Race, over 56"—Junior Division, grades 3-7
65. Pole Bending, 56" & under—Senior Division, grades 8-12
66. Pole Bending, 56" & under—Junior Division, grades 3-7
67. Pole Bending, over 56"—Senior Division, grades 8-12
68. Pole Bending, over 56"—Junior Division, grades 3-7

NOTE: 4-H Horse & Pony rules will be followed. Check your Horse and Pony Rule Book for additional rules and regulations related to each discipline.

4-H HORSE AND PONY EXTREME CHALLENGE (Formerly called TRAIL RIDING PROJECT)

****Will be held at the Fulton County Fairgrounds**

****Will be held during the 4-H Fair**

THE FOLLOWING CLASS IS A SEPARATE PROJECT

(You must sign up separately from the Horse & Pony Project on your enrollment form)

- 4-H Enrollment is from October 1 through January 15. Horse Identification/Enrollment deadline is May 1 and is to be done online at <http://v2.4-honline.com>
- A 4-H member may complete the Extreme Challenge project by attending 3 (three) Fulton County Horse and Pony 4-H Club meetings and 2 (two) Horse and Pony Workshop. Participants are encouraged to participate in the County 4-H Extreme Challenge, but may complete the project by submitting the Horse & Pony Record Sheet.
- **All animals must be sound and healthy, vaccinated (Eastern & Western Encephalitis, Rhino, Tetanus, Influenza, West Nile and Rabies are mandatory. Potomac and Strangles Vaccinations recommended) and turn in vaccination certificate papers by May 1.**
- **Judging will be held Tuesday morning and begin at 10:00 a.m.**

The purpose of this project is to:

1. Maximize the safety of all youth participating in the trail ride project.
2. Provide youth a fun, active, hands-on educational experience that will help them develop life skills such as confidence, leadership, cooperation and responsibility.
3. Present more experience to youth in relating to and working with their family, their peers, and people of different ages.
4. Promote a good time by learning in new, enjoyable ways while making new friends, belonging to a group, and giving and receiving acceptance and recognition.

Obstacle Course

- Riders will complete the course located in the arena to the best of their abilities. Riders will be timed in this event.
- **Possible obstacles *could* include:**

Logs and Ground	Mailbox	Bridge/Flower Boxes
Poles	Deer/Turkey Obstacles	Carrying a Flag
Water	Hula Hoops	Jumps
Crossing/Water Box	Backing Maneuvers	Pole Weaving
Drag Behinds	Shower Curtain Obstacles	Blowing Flags
Pool Noodle Obstacles		Round About

Tack and Equipment

- You may use tack or equipment that is considered to be standard in the industry and recognized events. It must be safe, humane, and in good working condition.
- Western tack and attire for the trail class as described in the 4-H Handbook is required.
- Shank/curb bits may be ridden with two hands.
- Helmets are required for all riders.
- Numbers must be worn on the exhibitor's back or visible on both sides of the saddle pad.
- Show management and judges may check equipment and horses at any time.

Judging Criteria

- *All judge's decisions are final.*
- At every obstacle, both riders and horses receive points (from 0 to 5). Rider points and horse points are combined for a total maximum of 10 points.
 - 0 passed on obstacle
 - 1 Oopsy daisy
 - 2 Mediocre
 - 3 Good
 - 4 Excellent
 - 5 Perfect
- Each obstacle is worth a total of 10 points for a total of 100 points possible.
- A judge may dismiss a rider from their obstacle for safety reasons.
- Some of the factors that you will be judged on are horsemanship, safety, and control. Your horse will be judged on attitude and performance.
- Riders should be considerate, patient, and kind with their horses at all times.
- Points are achieved by negotiating and completing obstacles smoothly, and with authority, and finesse.
- An ideal trail horse is one that is willing, calm, quiet, and attentive and responds appropriately to light cues. These horses demonstrate fluid motion in various maneuvers and stand still when asked.
- A refusal is a horse that moves their feet away (any direction) from the obstacle. Upon a third refusal or attempt a judge may tell a rider to move on to the next task in that obstacle or announce they have finished scoring and the rider should exit and go around the obstacle. Looking and snorting are not considered a refusal.
- Pausing at an obstacle, water crossing, or log crossing to sniff or investigate is allowed.
- Horses should be guided willfully without anxiety or apparent resistance such as balking or evading.
- Any movement made by the horse without rider direction or deviation from the pattern must be considered a lack of control.
- Horses that tick an obstacle won't be penalized as long as balance is maintained.
- Horses that dislodge obstacles and trip from a lack of coordination may be penalized.
- A fall is considered any involuntary dismount of a rider, a horse dropping to the ground above its knees, or a horse lying down in water, and will result in a zero score for the obstacle.
- Horses will not be penalized for stopping and drinking water at crossings.

Disqualifications

- Show management may ultimately disqualify a horse if it is obviously lame, sick, injured, or has unruly behavior.
- Any misconduct, unsportsmanlike behavior or harsh treatment towards a participant, horse, or judge will be grounds for disqualification.
- Riders falling off of their horse or pony will result in a disqualification.

Placings

- Animals will be placed 1st-5th place. Champion and Reserve Champion awards will be determined in Junior and Senior division. If in the event of a tie, the rider/animal that completed the course in the least amount of time will place above the rider/animal taking more time.

Guidelines for Accommodation of Children with Disabilities in the Indiana 4-H Horse and Pony Project

- Indiana 4-H programs and curricula must be accessible to the wide diversity of all children in the State of Indiana, regardless of their backgrounds and characteristics, including physical, mental, or emotional ability or limitations. The Indiana Horse and Pony Handbook (4-H 661) states on page 5:
- “4-H members with special needs are encouraged to show horses and show management may allow assistance and rule modifications when appropriate.” A shorter trail pattern will be set up for special needs participants.”
- The purpose of this document is to provide educators, leaders, and parents with some guidelines regarding appropriate accommodations. First and foremost, it must be remembered that the primary purpose of the 4-H program is to provide all youth the opportunities to grow and develop, and maximize their potential.
- 4-H Mission - To assist youth and adults in their development by conducting hands-on educational programs, using the knowledge base of Purdue University, other land grant universities and the United States Department of Agriculture.
- This mission statement indicates that 4-H conducts “hands-on learning programs”. Ideally, an accommodation should be made to allow a child with a disability to participate in the activity with their peers.

Any accommodations made should:

- Allow that the child with a disability may participate in the same collective activity. Observation of the activity without direct involvement does not constitute participation.
- Not adversely affect how other participants in the activity perform, or are judged or evaluated. Every effort should be made to minimize the effects of the accommodation on other participants.
- Examples of this type of accommodation include, but are not limited to, waiving ownership, or waiving one horse one rider, allowing a crop in a Western pleasure class, allowing an American Sign Language assistant in the ring, allowing a modified saddle, allowing the assistant in driving or allowing an assistant to help in a halter class.
- In situations where the accommodation makes participation in the same collective activity unsafe or disruptive to the other participants, it is suggested that an alternate activity be designed to allow participation. Examples of this type of accommodation would include, but not be limited to, a walk-trot riding class (with or without assistants), holding the activity on a nearby surface for the individual requesting this type accommodation, or development of a trail course with obstacles that the child is capable of negotiating.
- Consultation with a professional, who teaches or provides services to persons with the disability in question, is recommended to determine appropriate and reasonable accommodation.
- Please remember, our primary purpose in 4-H is to provide a positive, interactive learning environment for all of the youth in Indiana, and part of our responsibility as educators, leaders, and parents is to make the 4-H program accessible to all children who are interested in participating.



POULTRY



Birds Must be in 4-Her's possession by May 1. Enrollment Form due May 15.

May 15, 2022

July 1, 2022

TBA

July 1, 2022

July 1, 2022

July 9-16, 2022

Sunday, July 10, 2022

Monday, July 11, 2022

Thursday, July 14, 2022

Thursday, July 14, 2022

Friday, July 15, 2022

Friday, July 15, 2022

July 29-August 21, 2022

Paper Poultry Enrollment forms due in the Extension Office

Pen Cards due

Poultry Blood Testing

Deadline to register Poultry online for the State Fair without penalty

Deadline to register all animals in FairEntry

FULTON COUNTY 4-H FAIR

12:00 noon-2:00 p.m.—Poultry Check-in

9:00 a.m.—Mini 4-H Poultry Show followed by 4-H Classes & Showmanship—

Poultry Barn

5:00 p.m.—Supreme Master Showmanship

10:00 p.m.—Release Horse & Pony and Livestock Exhibits not in the sale

5:00 p.m.—Livestock Auction—Hudkins Arena

7:00 p.m.—Grand Champions Spotlight Sale—Hudkins Arena

INDIANA STATE FAIR

ANY EXHIBITOR MAY SHOW AT THE STATE FAIR - Contact the Extension Office. Please see BOAH Requirements following end of Fulton County Poultry Information. There is a change in record keeping requirements!

Volunteers are always needed and welcome! Please help with set up and tear down. We also need you to help in the Pork Producers booth. This helps us earn money for our barn. Be sure to read the board in barn for any announcements during fair week.

LIMIT - 20 POULTRY ENTRIES (Any combination) Plus three (3) entries of eggs

1. See General Livestock Requirements for all species. See rule #21, about appropriate dress code, all exhibitors must adhere to.
2. All poultry presented for exhibition must meet one of the following requirements:
 - Test negative for pullorum-typhoid within 90 days prior to the date of their exhibition OR
 - Be hatched from eggs originating from certified NPIP pullorum-typhoid clean flocks OR
 - Originate from a flock where the entire flock is certified NPIP pullorum-typhoid clean.
3. **Pen Cards must be turned in by July 1st to be able to show at fair.**
4. Birds must always have food and fresh water. If birds are not fed and watered sufficiently you will not be allowed to sell at auction. Food and water levels will be checked by committee at 10:00 a.m.
5. No medications may be administered to show animals without approval of Department Head and Executive Committee.
6. No poultry may be exhibited showing signs of infections, communicable diseases, external parasites, infestation, bleeding, or excessive feather loss. Dirty birds will be dropped one placing.
7. If a bird has been determined to be sick or otherwise unhealthy it will be sent home by the Department head or quarantined until 4-H Council and executive committee decides if bird needs to be sent home.
8. If a bird dies it can be substituted with another bird that has been previously listed on an enrollment form until pen cards are turned in. After that time the Department Head will decide if there is room for the change.
9. Only breeds and species recognized by the American Poultry Association Standard of Perfection may be shown.
10. **May sell 1 poultry project.**
11. Livestock projects must be shown by the owner except in emergency situations such as injury or illness. All other substitutions must have prior 4-H Council or 4-H Council Executive Committee approval. All requests must be submitted in writing. Pre-existing conditions need to be approved at least 48 hours prior to the show. Other situations will be handled as needed. **MUST BE PRESENT TO SHOW, IF NOT PRESENT, THEN BIRDS ARE NOT JUDGED.**
12. Awards: Trophies are awarded for "Best of Commercial Show" and "Best of Exhibition Show". Banners are awarded to the Division Grand and Reserve Grand Champions. Rosettes will be awarded to the class champions and reserve champions.

Order of Showmanship - Beginner, Junior, Senior, Master

In addition to the following exhibits, a 4-H member may also exhibit Poultry Science Display Board.

COMMERICAL CLASSES

1. **Commercial Eggs**
 - a. **Description:** Display six (6) eggs displayed in a cardboard carton. Limit one (1) entry of six (6) eggs PER CLASS for a total of 18 eggs. Eggs are disposed of by the Poultry Committee.
 - b. **Classes:**
 - i. White Shell Chicken Eggs
 - ii. Colored Shell Chicken Eggs (Brown, Blue, Green)
 - iii. All Other Eggs (Quail, Pheasant, Guinea, Duck, or Ostrich)
2. **Commercial Laying Chickens**
 - a. **Description:** Exhibit two pullets or two hens of a commercial breed of laying chickens. Pullets are female birds hatched between January 1st and May 1st of current year. Hens are hatched before January 1st of the current year. Limit two (2) pens per member.
 - b. **Classes:**
 - i. White Egg Shell Pullets
 - ii. White Egg Shell Hens
 - iii. Brown Egg Shell Pullets
 - iv. Brown Egg Shell Hens
 - v. A.O.V. Pullets
 - vi. A.O.V. Hens
3. **Commercial Meat Chickens**
 - a. **Description:** Exhibit two males or two females of a commercial breed of meat chickens such as dark, lace, or white Cornish Cross. Exhibitors must furnish date of hatch which will not be less than 42 days of age and not over 56 days of age at day of show. Limit two (2) pens per member.
 - b. **Classes:**
 - i. Fryers—Two (2) birds that are the same sex and weigh up to 5 pounds each
 - ii. Broilers—Two (2) birds that are the same sex weighing between 5 to 7 pounds each
 - iii. Roasters—Two (2) birds that are the same sex weighing between 7 to 10 pounds each
**Weight of heaviest bird in the pair determines which class the pair show in.*
4. **Commercial Geese**
 - a. **Description:** Exhibit two males or two females hatched between January 1st and May 1st. Limit two (2) pens per member.
 - b. **Classes:**
 - i. Embden
 - ii. A.O.V.
5. **Commercial Ducks**
 - a. **Description:** Exhibit two males or two females hatched between January 1st and May 1st. Limit two (2) pens per member.
 - b. **Classes:**
 - i. Pekin
 - ii. A.O.V.
6. **Commercial Turkeys**
 - a. **Description:** Exhibit one male or one female hatched between January 1st and May 1st. Limit two (2) pens per member.
 - b. **Classes:**
 - i. Broad Breasted White females
 - ii. Broad Breasted White males
 - iii. Broad Breasted Bronze females
 - iv. Broad Breasted Bronze males
7. **Commercial Meat Pigeons**
 - a. **Description:** Exhibit two males or two females of a utility breed pigeon hatched between January 1st and May 1st. Limit two (2) pens per member
 - b. **Classes:**

- i. Young Cocks
- ii. Young Hens

EXHIBITION CLASSES

1. **Exhibition Chicken**
 - a. **Description:** Exhibit one pullet, one hen, one cockerel or one cock. Chickens will be judged according to the Standard of Perfection of any age. Limit four (4) pens per class.
 - b. **Classes:**
 - i. American
 - ii. Asiatic
 - iii. Continental
 - iv. English
 - v. Mediterranean
 - vi. A.O.V.
 - vii. Clean Legged Bantams
 - viii. Feathered Legged Bantams
2. **Exhibition Waterfowl**
 - a. **Description:** Exhibit one pen which consists of either: one duck, one drake, one goose or 1 gander. Waterfowl will be judged according to the Standard of Perfection of any age. Limit four (4) pens per class.
 - b. **Classes:**
 - i. Heavy Duck
 - ii. Medium Duck
 - iii. Light Duck
 - iv. Bantam Duck
 - v. Heavy Goose
 - vi. Medium Goose
 - vii. Light Goose
3. **Exhibition Chicken Breeding Pair**
 - a. **Description:** Exhibit one breeding pair of exhibition chickens. Pairs need to be hatched before August/September of the previous year. Limit two (2) pens per class.
 - b. **Classes:**
 - i. Chicken Breeding Pair
4. **Exhibition Waterfowl Breeding Pair**
 - a. **Description:** Exhibit one breeding pair of ducks or geese. Pairs need to be hatched before August/September of the previous year. Limit two (2) pens per class.
 - b. **Classes:**
 - i. Duck Breeding Pair
 - ii. Geese Breeding Pair
5. **Exhibition Turkey Breeding Pair**
 - a. **Description:** Exhibit one breeding pair of exhibition-type turkeys. Pairs need to be hatched before August/September of the previous year. Limit two (2) pens per class.
 - b. **Classes:**
 - i. Turkey Breeding Pair
6. **Exhibition Guinea Fowl Breeding Pair**
 - a. **Description:** Exhibit one breeding pair of guineas. Pairs needs to be hatched before August/September of the previous year. Limit two (2) pens per class.
 - b. **Classes:**
 - i. Guinea Fowl Breeding Pair
7. **Exhibition Avian Stock Breeding Pair**
 - a. **Description:** Exhibit one breeding pair of pigeons. Pairs need to be hatched before August/September of the previous year. Limit two (2) pens per class.
 - b. **Classes:**
 - i. Fancy Pigeon Breeding Pair
 - ii. Sporting Pigeon Breeding Pair
 - iii. Utility Pigeon Breeding Pair
 - iv. Dove Breeding Pair

Recommended Practices to Protect Avian Health at Indiana Poultry Shows and Exhibitions-CHANGES IN RECORD KEEPING!

Standard biosecurity practices are important for Indiana’s poultry community, and recent findings of highly pathogenic avian influenza (HPAI) across the country present a higher level of risk to poultry flocks. The Indiana State Board of Animal Health (BOAH) recommends poultry owners and event organizers increase disease prevention practices before, during and after the event.

Steps to Take BEFORE the Exhibition

BIRD MEASURES

For Exhibition Organizers:

- Poultry exhibition organizers are required to notify BOAH of events at least 10 days prior to the opening day of the event. Organizers can meet this requirement by registering online (www.in.gov/boah/2726.htm), by mail or by email (animalhealth@boah.in.gov).
- Arrange event to minimize contact between exhibition birds and wild birds or wild waterfowl.
- Arrange to house exhibition poultry indoors.
- Remove food and water sources that attract wild birds.
- Limit the time birds are congregated and commingled at an exhibition. Different species (chickens, turkeys, ducks, geese) should be separated (no physical contact between different species) at the exhibition. Measures might include minimizing the total time birds are on the exhibition grounds. Ideally exhibition birds should be on the facility grounds for no more than 72 hours.
- Minimize interaction between birds from separate flocks.
- Establish a relationship with a veterinarian who will be present or on call for the duration of the exhibition.
- Designate an individual, such as the veterinarian, building manager, or show superintendent, who will be responsible for monitoring the animals for clinical signs, evaluating sick animals and taking additional steps as warranted to minimize the risk of illness in the birds. This individual will contact the Healthy Birds Hotline (866-536-7593), if birds appear sick.
- Establish a protocol to remove sick birds immediately from the exhibition area. Sick birds should not be housed on the exhibition grounds in a “hospital” pen.
- Exhibition organizers are required to maintain records of all participants in the show/event, including:
 - Name, address and contact information for each exhibitor
 - Number and breed/description (i.e., 3 Saxony ducks)

NOTE: Records must be retained for 3 years.
- Minimize contact between exhibition birds prior to event (limit meetings where poultry from separate premises are present).
- Consider including the following information in the show catalog or host a meeting with exhibitors prior to the start of the exhibition to distribute the following information:
 1. Contact information for a local veterinarian who will see birds
 2. Instructions on how to report bird illnesses (Healthy Birds Hotline: 866-536-7593) and explain any specific actions that may be required if a bird becomes sick at the show
 3. Review exhibition regulations
 4. Review and encourage disease control measures to be utilized during the exhibition, including the daily monitoring of the birds during the show, as well as for when the exhibitor returns home
 5. Public health information related to highly pathogenic avian influenza
- Consider consequences, and have a plan for how to proceed, if birds express signs of illness while at the event.
- Discuss biosecurity practices with exhibition staff. Minimize contact between flocks, including movement of people from flock to flock.

For Exhibitors:

- Birds travelling to Indiana from other states must comply with Indiana’s poultry health importation requirements, including a certificate of veterinary inspection written within 30 days and/or NPIP flock status documentation (such as the 9-2 or 9-3). Specific details are online at: www.in.gov/boah/2391.htm.
- Consult a veterinarian to understand and implement applicable biosecurity and bird health practices at home.
 1. Resources are available at: <http://1.usa.gov/1iEZZyX>
- Minimize contact with wild birds and waterfowl.
 2. House poultry indoors or, at minimum.
 3. Remove food and water sources that attract wild birds.
- Minimize the number of people who have contact with your birds; particularly limit contact between your flock and other people who own birds.
- Avoid personal contact with birds other than your own.
- Avoid personal contact with wildlife, especially wild birds and waterfowl.
- Keep tools and equipment clean.
 1. Clean cages and food and water containers daily.
- Wash hands with soap and water and wear clean boots and clothing to work with your birds.
 1. Wash and disinfect boots after working with birds.
 2. Consider having dedicated boots and clothing for working with your birds.
- Become familiar with the clinical signs of highly pathogenic avian influenza in birds:
 1. **Sudden death**
 2. Wheezing, coughing, nasal discharge
 3. Decreased energy
 4. Decreased feed intake
 5. Drop in egg production or egg quality
 6. Swelling and/or discoloration of eyes, head, neck
 7. Tremors, circling, drooping wings, twisting of head and neck
- Seek veterinary assistance if a bird becomes sick.
 1. Isolate sick birds immediately by moving them away from other birds and placing in a separate pen.
 2. Tend to sick birds **after** tending to healthy birds.
 3. If any birds exhibit illness within 14 days prior to traveling to the show, no birds (healthy or sick) from your flock should be taken to any shows or exhibitions.
 4. Personally refrain from attending bird shows and exhibitions (even without birds) if your birds are sick.
- Understand the risks of taking a bird to an exhibition.
- Ask the exhibition organizer about any specific actions that may be required if a bird becomes sick at the show.
- Refrain from attending another event with your birds for at least two weeks after returning from an exhibition to reduce the risk of spreading disease.

HUMAN MEASURES**For Exhibition Organizers**

- Establish methods to communicate rapidly (i.e., email addresses and/or phone numbers from show entry information, social media channels, etc.) with exhibitors about procedural changes or incidents associated with the exhibition.
 - Host non-animal-related activities (i.e., dances, pizza parties, etc.) in locations other than animal barns.

Steps to Take DURING the Exhibition

BIRD MEASURES

For Exhibition Organizers

- Birds travelling to Indiana from other states must comply with Indiana's poultry health importation requirements, including a certificate of veterinary inspection written within 30 days and/or NPIP flock status documentation (such as the 9-2 or 9-3). Specific details are online at: www.in.gov/boah/2391.htm.
- If a bird shows clinical signs consistent with influenza or other disease, exhibition staff should be notified as soon as possible, the bird should be removed from contact with other birds and the public, and the ill bird should be reported to the Healthy Birds Hotline (866-536-7593). The bird should be tested for avian influenza. The clinical signs of avian influenza are
 1. Sudden death.
 2. Wheezing, coughing, nasal discharge
 3. Decreased energy
 4. Decreased feed intake
 5. Drop in egg production or egg quality
 6. Swelling and/or discoloration of eyes, head, neck
 7. Tremors, circling, drooping wings, twisting of head and neck
- Exhibition staff should call the Healthy Birds Hotline if one or more birds become sick or have an unusual death.
- Record exit/release time of birds and maintain these records with other required records. Records must be retained for 3 years.

For Exhibitors

- Clean cages, food, and water containers daily.
- Do not share equipment with other exhibitors.
- Minimize contact between your birds and other birds as much as possible.
- Minimize your own contact with other birds.
- Minimize the number of people who have contact with your birds.
- Observe birds daily for signs of influenza-like illness.
- Report any influenza-like illness to the designated exhibition veterinarian or the appropriate exhibition staff so the bird can be evaluated.
- The individual designated to monitor bird health should call the Healthy Birds Hotline (866-536- 7593).
- Birds deemed to be ill should be removed from the exhibition immediately.

HUMAN MEASURES

For Exhibition Organizers

- Provide easy access to hand washing stations.
- Post informational signage that includes the following messages:
 1. No eating or drinking in the animal areas.
 2. Wash hands frequently.
 3. No pacifiers, sipping cups or strollers in the animal areas.
- If influenza-like illness is associated with the exhibition, the Healthy Birds Hotline should be notified immediately.

RABBITS

<i>May 15, 2022</i>	<i>Paper Rabbit Enrollment forms due—All housing requests are due to the Extension Office at the time of enrollment.</i>	
<i>June 24, 2022</i>	<i>Pen Cards due</i>	
<i>July 1, 2022</i>	<i>Deadline to register Rabbits online for the State Fair</i>	
<i>July 1, 2022</i>	<i>Deadline to register all animals in FairEntry</i>	
<i>July 9-16, 2022</i>	FULTON COUNTY 4-H FAIR	
<i>Sunday, July 10, 2022</i>	<i>4:00 -6:00 p.m.—Rabbit check-in</i>	
<i>Tuesday, July 12, 2022</i>	<i>4:00 p.m.—Mini 4-H Rabbit Show followed by Rabbit Showmanship & 4-H Rabbit Show—Rabbit Barn</i>	
<i>Thursday, July 14, 2022</i>	<i>5:00 p.m.—Supreme Master Showmanship</i>	
	<i>10:00 p.m.—Release Horse & Pony and Livestock Exhibits not in the sale</i>	
<i>Friday, July 15, 2022</i>	<i>5:00 p.m.—Livestock Auction—Hudkins Arena</i>	
	<i>7:00 p.m.—Grand Champions Spotlight Sale—Hudkins Arena</i>	
<i>July 29-August 21, 2022</i>	INDIANA STATE FAIR	

ALL EXHIBITORS MAY SHOW AT THE STATE FAIR - Contact the Extension Office.

IN ORDER TO COMPLETE THE RABBIT PROJECT, EACH MEMBER WILL BE REQUIRED TO CARE FOR AT LEAST ONE RABBIT AND COMPLETE THE ANIMAL RECORD SHEET.

County Fair Show Rules:

1. County Rabbit enrollment form to be at the County Extension Office by May 15th. **Form must show tattoos for all individuals. Assign identification numbers for all un-tattooed or unborn rabbits on enrollment form.**
2. Rabbits must be permanently earmarked in the left ear **before July 1**. Meat pens may be tattooed **after July 1**. **Tattoos must match numbers turned in on county enrollment form and pen cards.**
3. A 4-H member may not show more than 3 breeds of rabbits. (A Meat Pen is not considered a breed.)
4. A 4-H member may show a maximum of 12 pens plus a meat pen. A second meat pen may be shown if you have not met the 12-pen guideline.
5. There will be a **\$5 per family pen fee** for exhibitors in the Rabbit Barn. This fee will be collected at rabbit check in. This money will be used for shavings under the cages during the fair and to update and renovate the rabbit barn and cages as needed. Prizes will also be awarded at the end of the fair week. **Volunteers who help by working in the Pork Producers food booth the Saturday before the fair, rabbit barn set up and clean up can earn the fee waiver.**
6. **Rabbit check in is Sunday of fair week from 4:00-6:00 p.m.** No early check-ins will be allowed. All 4-H exhibitors must check-in their own rabbits. No rabbits will be released from the fair early unless approved by the Rabbit Committee.
7. **Classes are as follows: All Breeds: Mature and class weights vary by breed. Check the ARBA Standard of Perfection book for your breed.**
 - A. Heavy and Commercial Breeds (6 Class)**
 - Junior Buck or Doe - 4-6 months
 - Intermediate Buck or Doe - 6-8 months
 - Senior Buck or Doe - over 8 months
 - B. Small Breeds (4 Class)**
 - Junior Buck or Doe - under 6 months
 - Senior Buck or Doe - over 6 months

(No intermediate class in the small breeds.)

C. Meat Pens - A meat pen is made up of three rabbits of the same breed and variety.

- Each rabbit weighs 3.5 – 5.5 lbs. each and not over 70 days old.
- Must have a signed affidavit turned in during rabbit check-in to be able to sell.
- **ONLY MEAT PENS WEIGHING FROM 10.5 – 16.5 LBS. TOTAL WEIGHT WILL BE ALLOWED TO SHOW AND SELL.**
- There will be a Grand Champion and Reserve Grand Champion Meat Pen.

D. Single Fryers - A single fryer is one rabbit not over 10 weeks of age, weighing 3.5- 5.5 pounds and **CANNOT** be shown as a breed animal.

- A single fryer may be taken out of the meat pen.
- An Exhibitor may show two single fryers if he/she has not met the 13-pen maximum guideline.
- Must have a signed affidavit turned in during rabbit check-in to be able to sell.
- There will be a Grand Champion and Reserve Grand Champion Single Fryer.

F. Roaster and Stewer classes

- A roaster is a rabbit weighing 5.5 to 9 pounds and less than 6 months of age, on the day of show.
- A stewer is a rabbit weighing 8 pounds and over and 6 month or more, on day of show.
- Animals shown in roaster and stewer classes cannot be shown as breed animals.
- Must have a signed affidavit turned in during rabbit check-in to be able to sell
- There will be a champion roaster and a champion stewer at the fair

G. Pet Class – Any rabbit not recognized by the ARBA Standard of Perfection and can only receive ribbon placements. (This class not eligible for Best of Breed or Best In Show.) Pet class is open to any 1st year rabbit exhibitor who does not have another breed animal to show. 1 pet class animal per rabbit exhibitor.

8. **Rabbits will be judged as close as possible to the ARBA rules.**
9. Awards will be given to the Best of Each Breed (all varieties competing).
10. Rabbits sold or purchased after May 15th and prior to the Fulton County Fair shall not be eligible to show at the County Fair. (You CAN buy your meat pen, but you must have ownership **by July 1st.**)
11. Remark cards will be made out during check-in; 1 card per cage and will need exhibitor name, breed of rabbit, variety of rabbit, tattoo of rabbit, sex, and age of the rabbit.
12. A 4-Her may sell any meat class rabbit (meat pen, roaster, stewer, or single fryer) in the Livestock Auction.

RABBIT SHOWMANSHIP

Any 4-Her showing rabbits may participate. The 4-H Rabbit Showmanship project differs from other 4-H animal projects because it involves the judging of the person giving the presentation rather than the animal involved. 4-Hers are judged by how well they conduct a health evaluation of the animal.

The contest is divided into groups by grade:

1. Novice/Beginner – 4-H member in the 3rd, 4th, or 5th grade on January 1st of current year.
2. Junior – 4-H member in the 6th, 7th, or 8th grade on January 1st of current year.
3. Senior – 4-H member in the 9th, 10th, 11th, or 12th grade on January 1st of current year.
4. Master – Any previous Senior Showmanship Winners.

Any winner moves up to the next level, regardless of his/her grade level.

RABBIT ROYALTY SHOWMANSHIP CONTEST

A 4-Her must participate in county contest to advance to state contest

Any 4-Her enrolled in the rabbit project can participate in this contest. The 4-Her is judged on his/her knowledge of rabbits and showmanship skills in showing a rabbit. A written quiz and Breed ID will be given. The contest is divided into groups by grade (according to the Indiana State Fair Rules):

1. Novice – 4-H member in the 3rd or 4th grade on January 1st of current year.
2. Junior – 4-H member in the 5th or 6th grade on January 1st of current year.
3. Intermediate – 4-H member in the 7th or 8th grade on January 1st of current year.
4. Senior – 4-H member in the 9th or 10th grade on January 1st of current year.
5. Master – 4-H member in the 11th or 12th grade on January 1st of current year.

Any winner moves up to the next level, regardless of his/her grade level.

4-H RABBIT ILLUSTRATED - TALK CONTEST

An educational program that is open to any 4-H member. The 4-H Rabbit Illustrated Talk Contest will be implemented and sponsored by the Fulton County 4-H Rabbit Advisory Committee.

1. Each Illustrated - Talk should be original and of a practical nature related to some phase of the rabbit industry. Elaborate and expensive equipment cannot be justified.
2. The Illustrated - Talk should last 5 - 7 minutes. Judges will deduct points when the presentation exceeds maximum minutes allowed.
3. There will not be a limit on the number of 4-H Illustrated - Talk State Fair entries from a given county.
4. Each individual giving an Illustrated - Talk will receive an A, B, or C placing.
5. Previous winners may compete again, but must select and present a different topic.
6. 4-Hers may also use their 4-H Rabbit Poster as a part of their 4-H Illustrated - Talk.
7. 4-Hers may also take their Illustrated - Talk to the Area Demonstration Contest in the Livestock Division.



SHEEP

<i>April 29, 2022</i>	<i>Sheep ID Worksheet, County Bred & Born, Housing Requests due to Extension Office</i>
<i>Friday, May 6, 2022</i>	<i>5:30-7:00 p.m.—Sheep ID/Tag</i>
<i>May 15, 2022</i>	<i>Deadline to enroll sheep online—The enrollment will not be complete if the sheep are not enrolled online. Exhibitors who fail to register their animals online before the May 15th deadline will not be enrolled and therefore will not exhibit sheep at the county or state fair.</i>
<i>May 15, 2022</i>	<i>DNA Samples must be returned to office if going to State Fair</i>
<i>Coming Soon</i>	<i>Deadline to register Sheep online for the State Fair</i>
<i>June 25, 2022</i>	<i>Pen Cards due</i>
<i>July 1, 2022</i>	<i>Deadline to register all animals in FairEntry</i>
<i>Sunday, July 10, 2022</i>	<i>2:00-4:00 p.m.—Sheep check-in</i>
<i>July 9-16, 2022</i>	<i>FULTON COUNTY 4-H FAIR</i>
<i>Monday, July 11, 2022</i>	<i>12:30 p.m.—Mini 4-H Lamb Show followed by 4-H Sheep Show—Hudkins Arena</i>
<i>Thursday, July 14, 2022</i>	<i>5:00 p.m.—Supreme Master Showmanship</i>
<i>Thursday, July 14, 2022</i>	<i>10:00 p.m.—Release Horse & Pony and Livestock Exhibits not in the sale</i>
<i>Friday, July 15, 2022</i>	<i>5:00 p.m.—Livestock Auction—Hudkins Arena</i>
<i>Friday, July 15, 2022</i>	<i>7:00 p.m.—Grand Champions Spotlight Sale—Hudkins Arena</i>
<i>July 29-August 21, 2022</i>	<i>INDIANA STATE FAIR</i>

Sheep will do banners and eliminate awards rather than trophies for 2022.

2022 Fulton County 4-H Sheep Rules Terms and Conditions:

1. 4-H Animal Ownership, Possession and Exhibition Guidelines state that all sheep **must be owned** and in the possession of the 4-H member by May 1st.
2. All market lambs and all commercial ewes must be individually identified with a county-specific tag under the supervision of the county 4-H committee at the start of the project. Sheep going to the state fair will need an 840 tag and a five (5) digit ear tag for market lambs and commercial ewes. Registered ewes must be identified by an ID that corresponds to the ID listed on the ewe's registration paper and an 840 tag. All market lambs, commercial and registered ewes going to state fair must have a DNA sample on file with the Extension office by May 15. Envelopes may be picked up in the Extension office.
3. 4-H members may enroll ewe lambs on their 4-H Sheep Enrollment Forms but will be designating whether they intend to show them as market lambs or breeding ewes. A 4-H member may only show their ewe lamb(s) as a market lamb(s) or as a breeding ewe(s) at the Fulton County Fair. 4-H members may not show the same ewe lamb as both a market lamb and a breeding ewe in the 4-H sheep show in any given year.
4. The Indiana State Fair Board is requiring all Indiana Exhibitors to provide the Indiana State Board of Animal Health required Premises ID number on all entry forms for beef and dairy cattle, goats, swine and sheep.
5. 4-H exhibitors showing sheep will be required to turn a paper enrollment into the extension office no later than the listed turn-in deadline. After the May sheep identification check in, the exhibitor will then be responsible for enrolling their sheep online before the May 15th deadline. The enrollment will not be complete if the sheep are not enrolled online. **Exhibitors who fail to register their animals online before the May 15th deadline will not be enrolled and therefore will not exhibit sheep at the county or state fair.**
6. All sheep must be declared by breed at time of weigh-in. 4-Hers must declare the two (2) breeds they are bringing to the county fair in both ewes and markets at the time of sheep ID. No animal will be allowed to fall into any other class other than what it has been enrolled in. Ewes must present paperwork at the time of checking in at the fair. **If the ewe's paperwork fails to reach the exhibitor, the exhibitor is required to contact the department head no later than July 1st.** The ewe will be moved to a crossbred class and will not be eligible for the purebred class. (The ewe

will only be moved to crossbred if you have crossbred ewes enrolled. You are only allowed to exhibit 2 breeds of ewes. If you do not have crossbred ewes, the ewe will not be eligible to show.)

7. No changes can be made to paperwork after listed office turn-in deadline. You will need to decide whether or not you want your animal to be eligible for the Indiana State Fair. This will need to be decided at the time of weigh in. To be eligible for the Indiana State Fair, your animal must have DNA submitted to Extension Office and enroll on 4-H Online.
8. If an animal loses a tag, you must contact the extension office or department head within 24 hours. The department head will need to re-identify the animal according to the rules stated in the Fulton County Handbook.
9. To complete the project, members must complete the animal record sheet.
10. All sheep enrolled must have an identification tag (Flock ID and/or Scrapie tag) the day of scanning/ear tagging that matches the original paperwork turned into the office by April 30.
11. No sheep shall be enrolled in more than one person's name. Any sheep can only be enrolled in one member's name. No more than 10 market lambs, 10 ewe lambs and 10 yearlings' ewes (1-year-old or older) may be enrolled per member.
12. ALL HOUSING REQUESTS ARE DUE AT TIME OF ENROLLMENT to be approved by the Fulton County 4-H Council. **The sheep committee holds the right to perform/and will be performing UNANNOUNCED ANIMAL LOCATION CHECKS on enrolled sheep for the fair. Any individual that refuses a location confirmation check will result in those animals being disqualified.**
13. At the time of spring tagging, lambs with signs of ringworm, demitasses, foot rot, or sore mouth will be required to check in last.

ARRIVAL AND RELEASE PROCEDURES

1. Any decorations and signs above pens must be removed when sheep are released from fair or after the animal is sold in the auction. All exhibitors are required to clean and leave their assigned areas cleaned.
2. All animals must be inspected and approved by a designated Sheep Committee member before being allowed in the sheep barn. **No animal with fungus**, signs of illness, inappropriate shearing (more than 1/8 inch of hair above the knee and hock), or foot rot will be allowed to show. Please understand that you must remove blankets for the inspection team to fully inspect your animal. Animals will need to be show ready. The barn superintendent along with the sheep committee determines the health and well-being of animals. **Decisions made regarding animals' health are final.**
3. 4-H Members must furnish sawdust or wood shavings for bedding of sheep. Carpet, tanbark, mulch and sand may not be used as bedding for animals.
4. 4-H animals will be released at the published times and according to the rules stated in the Fulton County Fair Handbook. The failure to follow these rules will result in the exhibitor being disqualified from all awards/money/points towards project/and will not be allowed to sell in the auction. Yearling ewes may be released at the completion of the sheep show on Monday.
5. All market lambs and commercial ewes will be weighed at the time of check in on Sunday of fair week. This will determine the breaking of classes if necessary. The animal must use scale weight unless being shown as a purebred ewe with paperwork.
6. All lambs shown in market class and non-fitted ewes must be slick shorn within 5 days of fair check-in before being able to unload. This is shorn show ready.

7. **Sheep grooming may be done by current and past Fulton County 4-H members, and immediate family (mother, father, brother, sister, stepparents, legal guardian, grandparents), Fulton County 4-H Sheep Department Head and Sheep Department Committee members during the fair.**

Sheep Exhibitor Terms

1. Carefully read the official health terms and conditions, general terms and conditions and official ownership terms and conditions in the Fulton County Fair 4-H Handbook. Especially note terms and conditions on tampering, misrepresentation, conduct, drugs, etc. Animals painted or colored by any means that alter or misrepresent breed characteristics will be penalized under the fraud and deception rules. Signs of fake hair, air, or other illegal substances will result in disqualifying the animal.
2. Abuse towards fair animals will result in disqualification of the animal and exhibitor. Excessive abuse shall also include, but not be limited to, burning, stabbing, gouging, punching, use of electric shocker or other treatment which is considered cruel and inhumane treatment to show animals.
3. The direct application of ice, ice water, towels, alcohol, Freon or any other refrigerant to the hide of a lamb is strictly prohibited. Lambs must be dry when entering the show ring. There is to be no irritant placed at the dock of the lamb or painting to change breed characteristics. There is to be **no painting of animals**. If doing these things, the 4Her and/or animals will be disqualified.
4. A calming agent used during fair week must be administered in the presence of the Department Head. The 4-Her will be informed about drug withdrawal time and show rules. If any animal has been given a calming agent, that animal will not be allowed to show in showmanship classes. If a calming agent is used and it has a withdrawal period then that animal will not be eligible for sale.
5. The sheep committee reserves the right to request identification from any individual grooming any animal(s). (Only current and past Fulton County 4-Hers, parent, grandparent, committee member, sibling, step-sibling, and legal guardian.)
6. 4-H exhibitors having an entry in animal classes are expected to show their own animals (The exception would be if the exhibitor has more than one animal in any given class). In cases where this cannot be done, the owner may request another Fulton County 4-H member to serve as a substitute showman. Substitute showmen must be approved by the sheep committee prior to the showing of the animal(s) needing a substitute showman. Requests will only be granted for medical emergencies or circumstances deemed unavoidable by the 4-H show manager. Failure to be excused from a job and/or participation in a sporting event or sports practice will not result in a substitute showman being granted.
7. 4-Hers are responsible for keeping their pens and aisle areas clean at all times.
8. Lambs must stay within 50 feet of the Sheep Barn at all times.
9. Giving lambs products by either dose or Hypodermic Syringe shall be by a Licensed Veterinarian or with Department Head present. The Department Head must be notified of the situation and be present at the time of administering the drug.
10. **Drenching:** Drenching is not allowed from the time the sheep are checked in until after completion of the show. After the completion of the show, drenching may be done at the owner's discretion.
11. Sheep stand placement and tack area placement will be at the discretion of the Sheep Department Head.
12. ***Stands and Blowers-** stands and blowers will be allowed in a designated area on Monday during the listed times only. **Blowers may be used from the completion of sheep check-in until 12:30 (the start of the Mini 4-H Show). Stands may be used during the show but not blowers.** Stands must be removed from the fairgrounds at or before 10:00 p.m. on Monday.
13. There will be a pen check in the sheep barn in an effort to keep pens clean and our barn presentable. Each day at 5:00 p.m., there will be a subcommittee made up of members from the sheep committee to check pens. Everyone is required to clean out his or her pens daily and the aisle in front of their pen and have them looking good for the 5:00

p.m. check. Each 4-H member exhibiting sheep will be given a warning for the first time, if their pen is unsatisfactory. The second time that a pen is unsatisfactory; the 4-H'er will be fined \$5.00, which will be taken out of the auction check. If the pen still remains unclean, a \$5.00 fine will remain each day thereafter.

14. Pens must be viewable to the public. Boards and decorations cannot exceed 24 inches from the ground.

Sheep Enrollment/Showing Qualifications

1. Exhibitors may show 2 breeds of market lambs. (These will not need to be the same breed as ewes enrolled.) Each exhibitor may show up to 2 market lambs per breed for a total of 4 market lambs.
2. Exhibitors may show 2 breeds of ewes. Exhibitors may show 2 yearling and 2 ewe lambs of each breed. Total possible ewes shown: 4 yearlings and 4 ewe lambs.
3. All market lambs must be **born after January 1st**. Ewe lambs must be born between September 1st of the previous year and April 1st of the current year. Yearling ewes must be born within the last year between January 1st and August 31st.
4. An exhibitor may not show the same ewe lamb as both a market lamb and a breeding ewe in the 4-H sheep show in any given year. A ewe lamb can, however, be shown as a 4-H market lamb one (1) year and then shown as a yearling breeding ewe the following year.
5. All market lambs and commercial ewes must be slick sheared at a uniform length (1/8 inch).
6. All lambs must have actual weight of 70 lbs. to sell at the livestock auction.
7. Classes will be divided using the market lamb's weight. Commercial ewes will also be shown by weight. Registered ewes will show by age specified on registration papers. Natural Color Ewes must also be registered to show in the Natural Color breed class. If a ewe does not have papers, she must be retinal image scanned, ear tagged and shown as a commercial ewe.
8. Purebred market lambs must be born of purebred parents of the same breed and exhibit characteristics consistent with that breed.
9. All class winners will show for breed champion market lamb, and the second-place lamb to the breed champion may compete for reserve breed champion.
10. Commercial market lambs will be entered in either blackfaced or whitefaced classes. Blackfaced Commercial classes will be designated for blackfaced and predominantly blackfaced grade. Whitefaced Commercial classes will be designated for all whitefaced and predominantly whitefaced grade (more than 50% white on face and ears/speckled pattern on ears and legs). Both whiteface commercial and blackface commercial will show in their designated breeds.
11. All animals must show by breed according to what the original stated breed was on the enrollment papers. No animal will be allowed to switch breeds. Commercial (crossbred) both black and white are considered an individual breed.
12. Sheep enrolled as purebred at time of animal enrollment may NOT be moved to another purebred or crossbred breed. Example 1: A sheep enrolled as a Suffolk at enrollment cannot be moved to the crossbred or natural color class. Example 2: A sheep enrolled as crossbred cannot be moved to Hampshire Class.
13. All breeding sheep may be exhibited either shorn or with full fleece **except for Blackface, Crossbred, and Whiteface ewes.**

14. Except for commercial ewes, all breeding sheep must be registered, the registration number recorded with the breed association and the papers (no photocopies, carbon or FAX copies except a FAX directly from the national breed association to Fulton County Fair) in the possession of the exhibitor. The breeder's tag/tattoo must be worn if required by the breed association.
15. 4-Hers showing yearling ewes may have another Fulton County sheep member set the hind legs during their class. The 4-Her who owns the ewe must hold the head of the yearling ewe.

Country Born and Raised

Yearling Ewes may be shown as county born and raised.

1. All single-entry animals born in Fulton County and raised by a Fulton County 4-Her are eligible to be enrolled in this class on the special enrollment form.
2. Born and Raised animals **MUST BE IDENTIFIED** on the sheep enrollment form.
3. The highest placing county born market lamb, ewe lamb, and yearling ewe in each class will be shown for the selection of the highest placing county born sheep of its specific breed directly following the selection of the breed champion. The highest placing county born from each class will be shown for its specific breed champion county born. The breeds with qualifying animals will select one representative for the selection of the overall champion county born lamb. The selection of the county born breed representative will follow the selection of the breed champion sheep. (Unless the champion of the breed is the county born representative.)
4. The overall selection of the county born lamb will take place after the selection of the Grand Champion Market and Grand Champion Ewe. (unless the Grand Champion/Reserve Grand Champion are the county born representatives)

Dam and Daughter

There will be one class of Dam and Daughters. There will not be individual breed champions of Dam and Daughter selected. All breeds will show together where one champion will be selected.

1. The dam must have been owned and shown at a previous Fulton County 4-H Fair by the 4-Her. The daughter must be born and raised in Fulton County by the 4-Her and either be a ewe lamb or a yearling ewe.

All commercial dams must have their original Fulton County 5 Digit Tag. If the tag has been lost, a committee member needs to be contacted and the tag will be replaced with a new Fulton County tag.

2. Enrollment must be done on the Sheep Identification Enrollment form.
3. Maximum age for Dam is 5 years old.
4. Limit of 2 dam and daughter exhibits per 4-Her.

SHEEP SHOWMANSHIP QUALIFICATIONS

1. 4-H members who participate in 4-H sheep showmanship classes may only show their own animals that will be exhibited by them in a regular 4-H class. Showmanship will be judged on the fitting and training of the animal and the showmanship ability of the exhibitor.
2. Each 4-H member who competes in the sheep show may enter an animal in the showmanship contest.
3. **SHOWMANSHIP CLASSES.** Grade in school on January 1 of the current year.
 - a) **Beginner Showmanship**—all 4-H exhibitors in 3rd and 4th grades are eligible. Once an exhibitor is the overall beginner showman, the 4-Her is only eligible to compete in the junior or senior market lamb showmanship in future years.
 - b) **Junior Showmanship**—all 4-H exhibitors in the 5th, 6th, 7th, or 8th grades are eligible. Once an exhibitor is the overall junior market lamb showmanship winner, the 4-Her is only eligible to compete in the senior lamb showmanship classes in future years.
 - c) **Senior Showmanship**—all 4-H exhibitors in the 9th grade or above are eligible (exception only for any previous year's Junior showmanship winners). The 4-Her is only eligible to compete in the master lamb showmanship classes in the same year and future years once he or she has won senior.
 - d) **Master Showmanship**—any previous winner of senior or master showmanship will exhibit in this class. There must be two (2) participants to have a class.

SWINE

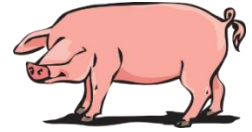

<i>May 15, 2022</i>	<i>Enrollment due May 15 online</i>
<i>May 15, 2022</i>	<i>Paper Copies of Housing Requests & County Bred & Born Forms—Due at Enrollment (MAY 15th)</i>
<i>Coming Soon</i>	<i>DNA hair sample due for State Fair</i>
<i>July 1, 2022</i>	<i>Deadline to register Swine online for the State Fair</i>
<i>July 1, 2021</i>	<i>Swine Pen Cards due</i>
<i>July 1, 2021</i>	<i>Deadline to register all animals in FairEntry</i>
<i>July 9-16, 2022</i>	<i>FULTON COUNTY 4-H FAIR</i>
<i>Saturday, July 9, 2022</i>	<i>7:00-10:00 p.m.—Swine Check-in</i>
<i>Wednesday, July 13, 2022</i>	<i>8:00 a.m.—Swine Show and Mini 4-H Swine Show (Mini 4-H Class will be first class after lunch break.)</i>
<i>Wednesday, July 13, 2022</i>	<i>10:00 p.m.—Release Swine not in the sale or carcass show</i>
<i>Thursday, July 14, 2022</i>	<i>5:00 p.m.—Supreme Master Showmanship</i>
<i>Friday, July 15, 2022</i>	<i>5:00 p.m.—Livestock Auction—Hudkins Arena</i>
<i>Friday, July 15, 2022</i>	<i>7:00 p.m.—Grand Champions Spotlight Sale—Hudkins Arena</i>
<i>Saturday, July 16, 2022</i>	<i>6:00 p.m.—Swine Carcass Show</i>
<i>July 29-August 21, 2022</i>	<i>INDIANA STATE FAIR</i>

IN ORDER TO COMPLETE THE SWINE PROJECT, 4-H MEMBER WILL COMPLETE THE ANIMAL RECORD SHEET AND LOCATION FORM.

ALL PUREBRED BARROWS AND GILTS SHOWN AT STATE FAIR IN RESPECTIVE BREED SHOWS MUST BE REGISTERED AND HAVE VALID REGISTRATION CERTIFICATES.

*****IMPORTANT: Youth are highly encouraged to fill out the optional paper enrollment with hand drawn ear notches which will be used to determine eligibility if the online enrollment is entered incorrectly. Please note this DOES NOT take the place of online enrollment! All pigs must be entered online by May 15th!**

*****IMPORTANT: A (1) family member MUST be present at one of the two clean up dates or a \$10 per 4-H member fine will be assessed. Family members must sign in/check in at the hog barn.**

*****IMPORTANT: Only the 4-H member and one other person, if needed, may be in the holding area. (That person must meet the requirements per the general livestock guidelines.)**

- All purebred barrows will be required to have registration papers to show. All purebred gilts will be required to have registration papers to show.
- A 4-H member may enroll a maximum of 15 gilts and 15 barrows online.
 - If you want to show a pig from the litter as a single (county or state fair) or in a pair (county fair only), then it must be listed on the online Swine Enrollment.
 - Animals are to be ear notched for identification; the same ear notch can be used only once per farm, per breed.
- A 4-H member may exhibit no more than 6 pigs in the swine project and 4 breeds of barrows and 4 breeds of gilts per 4-H member.
- BARROWS** - Will be shown by breeds.
 - Barrows will be shown by breed and weight. Classes will be arranged after weigh-in at fair
 - Purebred Barrows must have properly transferred papers that match the pig.
 - It will take 8 barrows to break a weight class
 - A 4-H member may show 4 single barrows - 2 barrows of one breed
- CROSSBRED BARROWS** - Will have 6-12 barrows per class.
- PUREBRED GILTS** - Will be shown by breed then by age. Purebred animals must be ear notched. Registration papers must match the pig.
- MARKET LITTERS** - Litters may be all barrows or a combination of gilts and barrows. Animals in a litter must

have same litter ear notch. Litter will consist of 4 animals. Each member may show 1 market litter.

8. **PAIR OF BARROWS** - Will be shown by breed.
 - a. Each member may show 1 pair,
 - b. Both barrows must be same breed.
 - c. Breeds will be shown by weight.
9. A 4-H swine committee member will check ear notches on your hogs if you so desire. Please notify the Extension Office or a committee member.
10. **All first-year members must have ear notches checked by a Swine Committee member, prior to the fair.**
11. All 4-H members must furnish either sawdust or wood shavings for bedding of swine.
12. There will be a pen check in the swine barn in an effort to keep pens clean and our barn presentable. Each day at 5:00 p.m., there will be a subcommittee made up of members from the swine committee to check pens. Everyone is required to clean out his or her pens daily and the aisle in front of their pen and have them looking good for the 5:00 p.m. check. Each 4-H member exhibiting swine will be given a warning for the first time, if their pen is unsatisfactory; the second time that a pen is unsatisfactory; the 4-Her will be fined \$5.00, which will be taken out of the auction check. If the pen still remains unclean, a \$5.00 fine will remain each day thereafter.
13. Drug free affidavits - Drug Free Affidavits are to be turned in to the Department Head at check-in of the fair stating ALL animals for slaughter are drug free.
14. Sale - Swine members have from check-in time on Monday to 1 hour after the Swine show to turn in the pig number that is to be sold. Information can be given to designated committee member on the day of show.
15. A pig must weigh a minimum of 210 lbs. at check-in to be sold in the livestock sale. The Swine committee will entertain reweighs for \$50 a head. The reweighs will be for people who complain/disagree with the "weigh-in" weight. This will be on a cash up front basis only. **This fee does NOT apply to animals that do not make weight for the sale.** Underweight sale hogs will still be reweighed on Thursday night by the swine committee. Persons with complaints may bring hogs and \$50.00 to the scales within 30 minutes of the completion of weigh-in on Saturday night.
16. Shots – Department Head must be notified and three committee members need to be present when shots are given to swine.
17. There will be a County Bred and Born barrow class.
18. Declaration of County Bred and Born barrows is required for eligibility. Barrows, MUST be identified by ear notch and breed on the 4-H pen card.
19. Any 4-Her that is deceptive and enrolls a pig in the County Bred & Born class and is proven not to be County Bred & Born, will not be eligible for the County Bred & Born class for the remainder of their 4-H tenure!
20. Barrow and Gilt entries for the 2022 Fulton County Fair must be born December 15 through March 31. Barrow and gilt entries for the 2023 Fulton County Fair must be born December 1 through March 31. Indiana State Fair entries remain January 1 through March 31.
21. All clipped hogs will be required to have at least ½ inch length of hair remaining or at least ½ inch length of re-growth on hogs to be eligible for show and sale. Hair length will be determined by the swine committee and their judgment is final.
22. There may be a screening committee that will classify hogs for breed characteristics. Breed characteristics can be found on the Indiana State Fair 4-H Swine information website: <http://www.in.gov/statefair/fair/contests/2474.html>

ANIMAL HEALTH REQUIREMENTS FOR EXHIBITION OF DOMESTIC ANIMALS IN INDIANA—2021

GENERAL REQUIREMENTS FOR ALL SPECIES

This document describes the Indiana State Board of Animal Health’s (BOAH) requirements for all animal exhibitions in the state. **HOWEVER, exhibition organizers may impose additional animal health requirements as a condition of entry. BOAH recommends contacting the exhibition organizer for specific information about requirements for each event.**

Please call the Indiana State Board of Animal Health at 877-747-3038 with questions concerning animal health requirements.

A. Limitations on Exhibition

This section describes limitations on exhibiting animals in Indiana. Other exhibition limitations may be described in the species-specific requirements that follow.

1. **Failure to meet all animal health requirements will result in removal of animals from the exhibition premises.**
2. The following animals **are not** eligible for exhibition in Indiana:
 - a. Animals that originate from a herd that is under quarantine.
 - b. An animal prohibited from exhibition under any law or order.
 - c. Any animal classified as a brucellosis “suspect”.
 - d. Animals showing signs of any infectious or communicable disease or that are a health hazard to people or other animals.
 - e. Any animal that does not meet state animal health requirements.
3. Any animal that develops or shows signs of any infectious or communicable disease during exhibition must be removed from the premises, including the surrounding exhibition grounds. An owner who is disputing the exclusion of his/her animal(s) from exhibition may not exhibit the animal in question pending any appeal.

The State Veterinarian is authorized to make the final determination as to an animal’s eligibility for exhibition. The state veterinarian may order removal of any animal from the exhibition grounds.

Exhibition organizers may impose health requirements in addition to those prescribed by BOAH. Added requirements may not contradict requirements imposed by BOAH.

Exhibition organizers may have a licensed and accredited veterinarian review animals and animal health documentation during the exhibition.

B. Certificates of Veterinary Inspection

1. **For animals that originate in Indiana**, contact the exhibition organizer to determine the certificate of veterinary inspection (CVI) requirement, if any.
2. **For animals that originate outside the state of Indiana**, the exhibitor must have a properly completed official certificate of veterinary inspection (commonly known as “health papers”) for the animal. This CVI requirement applies to all domestic animals (except for fish).
3. A certificate of veterinary inspection on any animal coming from outside Indiana for exhibition in Indianan is valid for 30 days from the date it is issued by a veterinarian.
4. Certificates of veterinary inspection accompanying animals for exhibition must be completed by a licensed and accredited veterinarian who has personally inspected the animals. CVIs must clearly include a description of each animal including the age, sex, and breed of the animal, and the official, individual identification.

5. Out-of-state swine and cattle attending an Indiana exhibition must have a pre-entry permit number noted on the certificate of veterinary inspection. Permits are available online at: www.in.gov/boah.
 - Certificates of veterinary inspection for all out-of-state swine and cattle going to the Indiana State Fair must have the import permit number for the 2021 Indiana State Fair, “**INSF21**”, written on the certificate.
6. Out-of-state poultry and hatching eggs attending an Indiana exhibition must be accompanied by one of the following documents.
 - a. An official certificate of veterinary inspection completed by a licensed and accredited veterinarian within 30 days immediately prior to the animals entering Indiana.
 - b. If the poultry or hatching eggs are from a flock participating in the National Poultry Improvement Plan (NPIP), they may move with the appropriate NPIP inspection/testing/participation certificate or records.
7. All out-of-state cervids (deer and elk) must have a permit approved by BOAH at least 5 business days before the movement into the state. Contact BOAH cervid programs to obtain a pre-entry permit.
8. A copy of the official certificate of veterinary inspection for each animal exhibited must be on file at the State Veterinarian’s office prior to the opening day of the exhibition.

C. Identification

All exhibition animals must be permanently and individually identified by an acceptable method. Official ear tags are tags approved by the USDA. Official ear tags must bear the US shield to be considered official identification (official ear tags placed before March 11, 2015 that do not have the US shield will be accepted.) official identification acceptable for specific species of livestock exhibited in Indiana are as follows:

CATTLE

- 840 tags may or may not be RFID (radio frequency identification), 15 digits, beginning with 840
- NUES (brite) tags, steel or plastic
- Official USDA program tags, such as orange calthood vaccination tags.

SHEEP AND GOATS

- Scrapie program flock tags
- Electronic implant (goats only), for breed-registered animals only when noted on registration paperwork
- Tattoo, if accompanied by registration papers with tattoo noted.
- Tattoo of the scrapie flock ID number along with an individual animal ID number
- Wethers younger than 18 months of age must bear a unique, permanent ID of any form (not necessarily an official/scrapie tag)

SWINE

- Official 840 ear tag (electronic—RFID or visual tag)
- NUES tag, plastic or steel
- Official Premises ID Number (“PIN”) tag**
 - ***Note Official PIN tags MUST include a premises number and unique animal ID imprinted by the manufacturer. (Standard PIN tags usually do not include an individual ID number; therefore, owners need to specify when ordering.)*
- Ear notch, if the ear notch has been recorded in the book of record of a purebred registry association
- Tattoo, if the tattoo is registered with a swine registry association

HORSES

- Physical description of the animal including: name, age, breed, color, gender, distinctive markings, cowlicks, scars, blemishes, biometric measures, brands, tattoos, etc.
- Digital photographs
- USDA-approved electronic implant (microchip)

LLAMAS/ALPACAS

- Official ear tag
- Tattoo
- Electronic identification implant (microchip)
- Digital photographs sufficient to identify the individual animal

CERVIDAE (Deer, Elk, and Moose)

Must have two forms of identification. One form must be an official ear tag.

- Official ear tag
- Tattoo
- Electronic identification implant (microchip)
- Farm ear tag

ALL OTHER SPECIES

- Physical description sufficient to identify the individual animal

If any additional identification other than the official identification is present, one of the additional identifications should also be listed on the certificate of veterinary inspection.

D. Testing

All tests required for exhibition must be conducted at the Animal Disease Diagnostic Laboratory (ADDL) at Purdue University, a laboratory approved by the Indiana State Board of Animal Health or a state or federal-approved laboratory.

SPECIES SPECIFIC REQUIREMENTS

CATTLE

1. **SEE GENERAL REQUIREMENTS FOR ALL SPECIES.**
2. **Cattle from Indiana** do not need a brucellosis test or a tuberculosis test for exhibition in Indiana.
3. **Cattle from states that are not designed tuberculosis free by USDA** must meet additional requirements for entry into Indiana. Contact the Indiana State Board of Animal Health for specific information.
4. **Cattle from outside the state** do not need a brucellosis test as long as the state of origin is classified as brucellosis free by USDA.
5. All cattle, including Indiana cattle, that are to be offered for sale at an exhibition must have the necessary testing and other requirements completed within 30 days prior to the sale date.

For more information on cattle health requirements, call the Indiana State Board of Animal Health at (317) 544-2400 or visit BOAH's website at: www.in.gov/boah.

SHEEP AND GOATS

1. **SEE GENERAL REQUIREMENTS FOR ALL SPECIES.**
2. Blankets must be removed from all sheep at the time of arrival.
3. All sheep wethers must be presented slick-shorn for inspection at arrival.
4. No sheep or goats may be exhibited that are showing signs of being infected with ringworm.

For more information on sheep and goat health requirements, call the Indiana State Board of Animal Health at (317) 544-2400 or visit BOAH's website at: www.in.gov/boah.

SWINE

1. **SEE GENERAL REQUIREMENTS FOR ALL SPECIES.**
2. Brucellosis testing
 - Swine from Indiana do not need a brucellosis test
 - Swine from outside the state do not need a brucellosis test, as long as the state of origin is classified brucellosis free by USDA. A certificate of veterinary inspection is still required.
3. Pseudorabies testing
 - Swine from Indiana do not need a pseudorabies test.
 - Swine from outside the state do not need a pseudorabies test as long as the state of origin is classified pseudorabies free by USDA. A certificate of veterinary inspection is still required.
4. All swine that are to be sold at a breed sale should have a certificate of veterinary inspection issued within **30** days prior to the sale to facilitate interstate movement after the sale.

For more information on swine health requirements, call the Indiana State Board of Animal Health at (317) 544-2400 or visit BOAH's website at: www.in.gov/boah.

HORSES

1. **SEE GENERAL REQUIREMENTS FOR ALL SPECIES.**
2. Horses coming from outside Indiana for exhibition in Indiana must meet the following requirements:
 - Each horse must test negative for equine infectious anemia (EIA) (a "Coggins test") within 12 months of the date of exhibition. Each horse must be accompanied by an official certificate of veterinary inspection that indicates the results of the EIA test
 - A suckling foal accompanying a dam that has tested negative for EIA within 12 months of the exhibition is exempt from the EIA testing requirement.
3. The following applies to horses coming from Indiana for in-state exhibition:
 - A certificate of veterinary inspection is not required.
 - An EIA test is not required.

For more information on horse health requirements, call the Indiana State Board of Animal Health at (317) 544-2400 or visit BOAH's website at: www.in.gov/boah.

NOTICE: Indiana State 4-H imposes vaccination requirements for horse show participants beyond the requirements of the Indiana State Board of Animal Health minimum requirements. Check with your local 4-H Purdue Extension educator for those requirements.

LLAMAS/ALPACAS

1. **SEE GENERAL REQUIREMENTS FOR ALL SPECIES.**
2. No test is required on any llamas or alpacas for exhibition in Indiana.

For more information on llama/alpaca health requirements, call the Indiana State Board of Animal Health at (317) 544-2400 or visit BOAH's website at: www.in.gov/boah.

CERVIDAE (Deer, Elk, and Moose)

1. **SEE GENERAL REQUIREMENTS FOR ALL SPECIES.**
2. **Cervids from within Indiana**, 12 months of age and older that are to be exhibited in Indiana must meet one of the following requirements.:
 - Test negative for **tuberculosis** within 90 days prior to the date of the exhibition.
 - Originate from a herd that is accredited under a state tuberculosis accreditation program. 345 IAC 2.5-5-4.
 - From a herd that meets other herd testing standard described in 345 IAC 2.5-5-3(1)
3. All cervide species that are known to be susceptible to **chronic wasting disease (CWD)** that are to be exhibited in Indiana must originate from a certified CWD program heard defined under the Indiana requirements. 345 IAC 2-7-4.
4. **Cervids from outside Indiana** must meet one of the following requirements:
 - **Must be CWD non-susceptible species (fallow deer)**
 - Originate from an accredited herd. 345 IAC 1-3-29
 - Have two tuberculosis tests, 90 days apart, with the last test within 90 days of entry to Indiana. 345 IAC 1-3-29.

For more information on cervidae health requirements, call the Indiana State Board of Animal Health at (317) 544-2400 or visit BOAH's website at: www.in.gov/boah.

POULTRY

1. **SEE GENERAL REQUIREMENTS FOR ALL SPECIES**
2. Indiana defines poultry as: chickens, turkeys, ostriches, emus, rheas, cassowaries, waterfowl (domesticated fowl that normally swim, such as ducks, geese, and swans), and game birds (domesticated fowl such as pheasants, pea fowl, partridge, quail, grouse, and guineas).
3. All poultry presented for exhibition, except waterfowl, must meet **one** of the following requirements:
 - Test negative for pullorum-typhoid within 90 days prior to the date of their exhibition.
 - Be hatched from eggs originating from certified NPIP pullorum-typhoid clean flocks.
 - Originate from a flock where the entire flock is certified NPIP Pullorum-typhoid clean.

For more information on poultry health requirements, call the Indiana State Board of Animal Health at (317) 544-2400 or visit BOAH's website at: www.in.gov/boah.

DOGS

1. **SEE GENERAL REQUIREMENTS FOR ALL SPECIES.**
2. Each dog presented for exhibition must be accompanied by a certificate of vaccination or other statement, signed by a licensed and accredited veterinarian, that indicates the vaccinations each animal has been give. A certificate of veterinary inspection may be used to document vaccinations, but is not required for dogs within Indiana.
3. All dogs 3 months of age and older must be vaccinated for rabies by a licensed and accredited veterinarian in accordance with the state rabies vaccination law. A certificate of vaccination for rabies must accompany the animal to the exhibition.

NOTICE: Indiana State 4-H imposes vaccination requirements for dog show participants beyond the requirements of the Indiana State Board of Animal Health minimum requirements. Check with your local 4-H Purdue Extension educator for those requirements.

For more information on dog health requirements, call the Indiana State Board of Animal Health at (317) 544-2400 or visit BOAH's website at: www.in.gov/boah.

CATS

1. **SEE GENERAL REQUIREMENTS FOR ALL SPECIES.**
2. Each cat presented for exhibition must be accompanied by a certificate of vaccination or other statement, signed by a licensed and accredited veterinarian, that indicates the vaccinations each animal has been given. A certificate of veterinary inspection may be used to document vaccinations, but is not required for cats within Indiana.
3. All cats older than 3 months of age must be vaccinated for rabies by a licensed and accredited veterinarian in accordance with the state rabies vaccination law.

NOTICE: Indiana State 4-H imposes vaccination requirements for cat show participants beyond the requirements of the Indiana State Board of Animal Health minimum requirements. Check with your local 4-H Purdue extension educator for those requirements.

For more information on cat health requirements, call the Indiana State Board of Animal Health at (317) 544-2400 or visit BOAH's website at: www.in.gov/boah.