



GIFT WRAPPING CHECKLIST

Required for Exhibit

- _____ **Fill out the Indiana 4-H Craft Record Sheet (4-H618) and turn in to club leader for his or her signature.**
- _____ **Create fair exhibit according to Gift Wrapping Guidelines and the Elkhart County 4-H Handbook.**
- _____ **Fill out the 4-H Craft Information Card (4-H 618a-W) and bring with finished project to project check-in**

Resources available in Extension Office

Gift Wrapping Manual, Elkhart County 4-H Handbook, www.extension.purdue.edu/elkhart

Revised 10/2022

Purdue University is an affirmative action, equal access/equal opportunity institution.

4-H Craft Information Card

4-H 618a-W
New 10/2012

4-H Member Name _____ County _____ Grade in School _____

What is the title of your exhibit, or its purpose?

Was this exhibit completed from a purchased kit or an original design?

Describe how this exhibit was constructed/crafted. (What did you do?)



Indiana 4-H CRAFT RECORD

Check area of interest selected

- Fine Arts
- Needlecraft
- Basic Crafts

List specific art or craft. _____

Division _____

NAME _____ GRADE _____

NAME OF CLUB _____ YEAR IN CLUB WORK _____

I have reviewed this record and believe it to be correct.

Signature of Leader _____ Date _____

How have you helped others to learn your selected art or craft? (Give brief description of demonstrations, news articles or other activities)

What experiences did you have in judging this project?

Where did you receive information or Instruction in this project?
(List persons who gave instruction; reference material, etc.)

4-H ARTS AND CRAFTS RECORD

NAME OF ARTICLE _____

MATERIALS PURCHASED	WHERE	COST

Total Cost _____

When was the article started? _____ Total hours spent on article _____

When finished? _____ How is the article to be used? _____

NAME OF ARTICLE _____

MATERIALS PURCHASED	WHERE	COST

Total Cost _____

When was the article started? _____ Total hours spent on article _____

When finished? _____ How is the article to be used? _____

It is the policy of the Purdue University Cooperative Extension Service that all persons have equal opportunity and access to its educational programs, services, activities, and facilities without regard to race, religion, color, sex, age, national origin or ancestry, marital status, parental status, sexual orientation, disability or status as a veteran. Purdue University is an Affirmative Action institution. This material may be available in alternative formats.

1-888-EXT-INFO

<http://www.agcom.purdue.edu/AgCom/Pubs/menu.htm>

Score Card:

Elkhart County 4-H Gift Wrapping Project

Name _____

Placing _____

Club _____

Division _____

	Excellent	Good	Needs Improvement
1. Neatness Corners Paper Tape Trim and bow			
2. Color and material coordination.			
3. Theme carried out.			
4. Creative and imaginative.			
5. Meets requirements.			



Some manuals are used more than one year. An additional copy will cost \$1.00.

AN ELKHART COUNTY 4-H PROJECT MANUAL

Welcome to the 4-H Gift Wrapping Project!

It is our hope that you will enjoy your years in this project and learn a fun and cost-effective skill.

Table of Contents

1. Project Exhibit Requirements	pages 1-2
2. Preparing the Gift for Wrapping	pages 3-4
3. Wrapping and Decorating	pages 5-8
4. Making Bows	pages 8-18
5. Adding Decorative Trimmings	pages 18-19
6. Decorating Your Own Paper	pages 20-23
7. Gift Bags	page 24
8. Packages for Shipping/Mailing	page 25
9. Wrapping Without a Box	page 25
10. Sample Score Card	page 26
11. Gift Wrapping Record Sheet	pages 27-28

Reference Materials:

Easy, Beautiful Gift Wraps – Lorraine Bodger, Harper & Row, New York. Call Number 745.54 BOD

Gift Wrapping: A Do-It-Yourself Guide – Adelaide & Josephine Shaw, Arc Books, Inc., New York. Call Number 745.54 SHA

Wrap It Up! Creative Gift Wrapping for all Occasions – Ruth Katz, Doubleday & Company, Inc., New York. Call Number 745.54 KAT

These books are available at the Goshen Public Library. Check craft stores and bookstores for other reference materials.

Revised November 2017

Elkhart County 4-H Gift Wrapping



General Rules: DO NOT put a gift in the wrapped package (*except where required in Level D*). Each wrapped package should include an index card containing the following information:

- 1) Theme
- 2) Occasion for the gift
- 3) Gender and age of the recipient.

The 4-H'er may do an action demonstration in addition to exhibiting their wrapped package.

Project Exhibit Requirements:

Level A (Grades 3 & 4):

Exhibit one wrapped package that follows the specifications and techniques listed below. Use a different shape box and bow each year.

- Wrap one package using a square, rectangle or flat box (maximum 18 inches in any direction) or decorate a purchased gift bag.
- Wrapping material may be any pre-printed paper (i.e. purchased wrapping paper, newspaper, comic strip paper).
- Bows may be self-made or purchased.
- Decorative trimmings or enhancements may be added to the package or gift bag. Trimmings and enhancements are optional and are the choice of the 4-H member. Examples include ribbon, toys, candy, flowers, etc.

Level B (Grades 5 & 6):

Exhibit one wrapped package that follows the specifications and techniques listed below. Use a different shape box and bow each year.

- Wrap one package using a round, cylinder, or oval shaped box (maximum 18 inches in any direction).
- Wrapping material may be any pre-printed paper (i.e. purchased wrapping paper, newspaper, comic strip paper).
- Bows must be self-made bows from one material. NO purchased bows.
- Decorative trimmings or enhancements may be added to the package. Trimmings and enhancements are optional and are the choice of the 4-H member. Examples include ribbon, toys, candy, flowers, etc.

Level C (Grades 7 – 9):

Exhibit one wrapped package that follows the specifications and techniques listed below. Use a different shape box and materials each year.

- Wrap one package using a square, rectangle, flat, or cylinder shaped box (maximum 18 inches in any direction).
- Decorate your own creative paper. Use your imagination - decorate with stickers, stamping, decoupage, painting, dyed, string art, spin art, etc. No pre-printed paper may be used.
- Bows must be self-made from one or more materials. NO purchased bows.
- Decorative trimmings or enhancements may be added to the package. Trimmings and enhancements are optional and are the choice of the 4-H member. Examples include ribbon, toys, candy, flowers, etc.
- **See page 20 of this manual for decorating ideas.**

Level D (Grades 10 – 12):

Choose one of the following options for exhibit. Use a different option each year. Exhibits may not exceed a maximum of 18 inches in any direction. **You may decorate your own paper. See page 20 of this manual for decorating ideas.**

1. Wrap one package that is an irregular shape (such as octagon, heart, etc.). You may not use any shape from an earlier level.
2. Make your own gift bag from non-traditional materials. NO purchased gift bags may be used.
3. Exhibit one set of wrapped packages in a tier.
4. Exhibit one oddly shaped gift (such as a football, sand pail, etc.) wrapped without using a box. **The gift must be included.**

For all options:

- Use non-traditional wrapping materials (i.e. fabric, natural materials, recycled materials, metallic materials, cellophane, etc.) to wrap the package. No pre-printed paper may be used.
- Bows must be self-made using two or more materials. No purchased bows.
- Exhibit must have at least one decorative trimming or enhancement as described above.

I. PREPARING THE GIFT FOR WRAPPING

Before a gift item is to be wrapped, it may require some advanced preparation. Remove the price tag. If the item is wrinkled, press it. If the gift needs dusting, polishing, decorating, or trimming, do whatever is necessary to make it look attractive.

BOX SELECTION

Putting the gift in a box enables the giver to wrap it with greater ease. Most articles need to be put in a box to maintain the gift's shape. If no box comes with the gift, be sure to select one that is the correct size.

GUIDELINES FOR SELECTING A BOX:

1. Select a clean box in good condition.
2. Select a sturdy box with straight corners.
3. The gift should fit the box, leaving only a small amount of space between the box and gift. If the box is too small, the contents will bulge and the wrapping may burst. If the box is too large, the contents may slide around inside and break or become wrinkled.
4. Common box shapes are rectangular, square, and cylindrical. Odd-shaped boxes are difficult to wrap.

BOXING THE GIFT

If the gift is clothing or material items, line the box with tissue as shown:

Fold the tissue paper in the center so that it will fit in the bottom of the box. The paper should be wide enough to cover the bottom of the box and completely cover the top of the gift.

In the case of odd-shaped items, small pieces of crumpled tissue paper can be placed at proper points so that the item will not break or rattle. Often a combination of both can be used to make the package neat inside as well as outside.

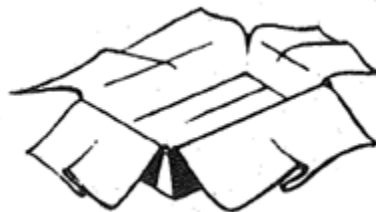

SELECTING WRAPPING MATERIAL

Decide on the gift and occasion before selecting the wrapping paper. When selecting wrapping paper, ask the following questions:

1. What paper is available?
2. Is there enough paper to wrap the gift?
3. Does the paper suit the occasion?
4. Does the paper take into account the age and sex of the receiver?
5. Is the design in proportion to the size of the box?

In addition to purchased wrapping paper, the following items might also be used for wrapping materials:

Foil	Wallpaper	Fabric
Newspaper	Bath Towels	Scarves
Sunday Comics	Washcloths	Socks
Dish Cloths	Baby Blankets	Brown Wrapping Paper
Shelf Paper	Burlap	Cloth Diapers

****If any of the above items are used, exhibit should not be marked down.****

DETERMINING THE AMOUNT OF PAPER NEEDED TO WRAP A GIFT

To determine the amount of paper needed to wrap a box, use the following guidelines:

Length of paper – Measure around the box and allow for enough extra paper so that it will overlap a little over half the width of the open end.

Width of paper – Measure the width of the box, add the height of the box, and add $\frac{1}{2}$ to 1 inch.

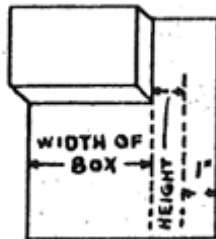

II. WRAPPING AND DECORATING

The secret to making a neatly wrapped package is in the way the paper is handled. Paper cut to the proper size will allow you to pull the paper firmly around the package and fold the ends in flatly and smoothly.

WRAPPING INSTRUCTIONS FOR A RECTANGULAR OR SQUARE GIFT:

1. Determine the amount of wrapping paper needed.
2. Tape the lid of the box, if needed, to prevent bulges and make the box firm for wrapping.
3. Place the box upside down on the wrong side of the open sheet of gift wrap. If the paper has a pattern or printed message, make certain the design is properly centered on the box to show its best advantage.
4. Bring one side of the paper up over the package; it should extend just beyond the center. Fasten paper to box with transparent tape.
5. Turn in the other side of the paper about $\frac{3}{4}$ inch and crease it sharply. Bring it up over the package and secure with tape or seals. This will be the bottom of gift when finished. Once the basic skills are mastered, rubber cement, double stick tape, or rolled pieces of tape may be used to make a neater looking package. The less you see, the better the look.
6. The ends may be folded in two different ways, depending on the shape of the box and personal preference.
 - a. Fold top flap down toward the center.
 - b. Fold both side flaps toward the center.
 - c. Bring the bottom flap up and tape in place.
 - d. Repeat procedure on the other side. Be sure that the paper is kept tight.

OR

- a. Fold both sides toward the center, mitering the corners.
 - b. Fold the top flap down and the bottom flap up (turning under about $\frac{1}{2}$ inch) and secure. This method is preferred on deep boxes.
7. Turn the package over so that the smooth side is on top.

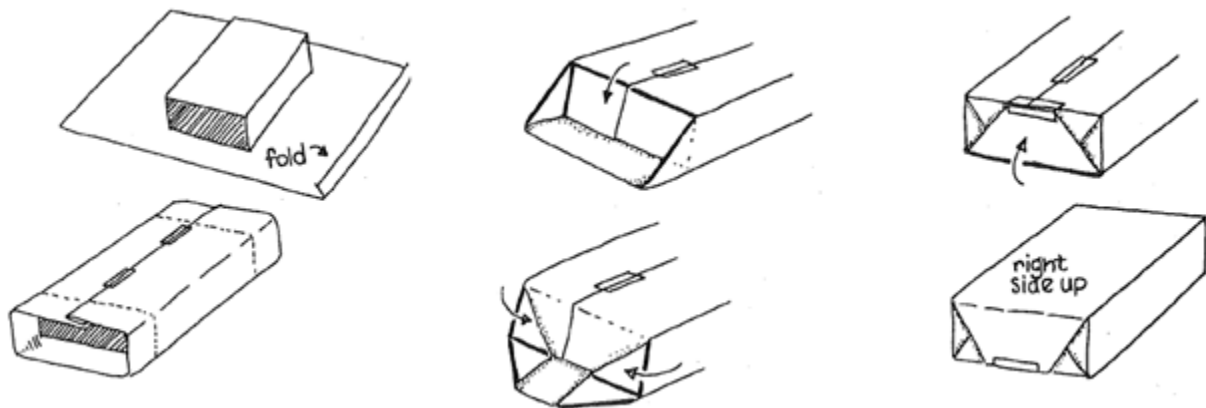

WRAPPING A CYLINDER

SMOOTH ENDS

1. Trace the ends of the cylinder and cut out two circles of the wrapping paper.
2. Wrap the cylinder with wrapping paper allowing an overlap on both ends.
3. Fold the overlap at the ends (cutting is sometimes necessary) and paste down. Be careful not to get paste on the gift.
4. Paste circles over folds.

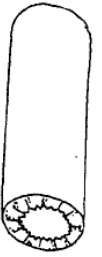

GATHERED ENDS

1. Wrap the gift in wrapping paper, allowing enough for ends to be gathered and tied. Tape securely in the middle of paper.
2. Gather paper at the ends and tie securely.

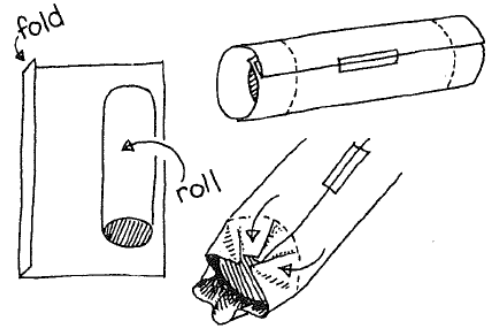

FRINGED ENDS

1. Follow steps for Gathered Ends.
2. Cut ends in strips to make fringe.

A combination of smooth and fringed ends may be used.

PERSONALIZING A PACKAGE

A cylinder shaped package may be personalized by using the wrapped cylinder as a base and making it into an object appropriate for the receiver. The package might be made into a truck, a fire engine, a clown, a drum, or many other things. Use your own imagination!

Turn a cylinder into a clown by using a Styrofoam ball for the head and making arms and feet from construction paper. Make a collar from ribbon and add a hat to complete.

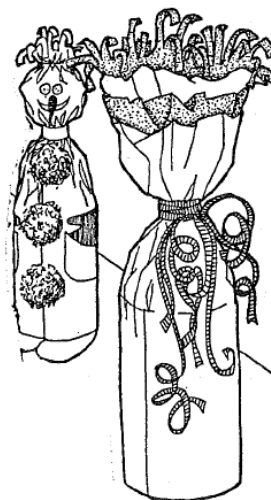

DECORATING THE PACKAGE

After the gift has been wrapped, think about the types of bows and decorations that can be used on the gift. Each package should have its own personality.

The decoration of the gift is complete when the wrapping paper, ribbon, bows, and/or decorations are combined effectively to create a pleasing overall appearance.

USING RIBBON

Ribbon is usually wrapped around the box to which the bow is attached. Listed below are guidelines for using ribbon.

1. The ribbon selected should complement the wrapping paper. Color may either contrast or match.
2. Choose ribbon in a width that is in proportion to the size of the box; the larger the box, the wider the ribbon that may be used. Strips of narrow ribbon may be used instead of one strip of wide ribbon.
3. Ribbon can be placed at the corners, along the length, or along the width of the box. It can also be repeated several times.
4. Simplicity is often the key to attractive packages; too much design or trim, or too many colors can be distracting.
5. Many times a plain package may be dressed up by making a pattern using just the ribbon or other decorative materials for the design (see examples below right).
6. The ribbon must be secure. A loose ribbon can ruin a pretty package.
7. After ribbon is applied, a bow may be tied, taped, or pasted to the package.

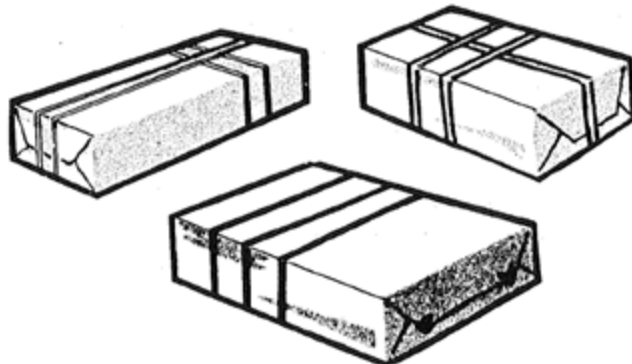

Methods commonly used to attach ribbon are the center wrap and the corner wrap.

CENTER WRAP:

1. Lay one end of ribbon on top of the box in the center, leaving a 4-5 inch end free.
2. Holding at the center top with one hand, with the other hand, wrap ribbon around ends of the box, cross at right angles, and wrap around sides of the box.
3. Bring to the center top and tie securely. Cut ribbon with 4-5 inches remaining for attaching bow.

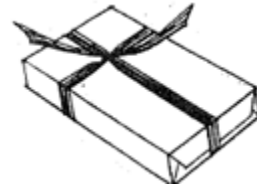

CORNER WRAP:

1. Starting at upper left corner, draw ribbon slantwise to top of box, under upper right corner, up and over lower right corner, under left corner, and back to starting point.
2. Join ends securely on the face of the box where the bow will be placed.

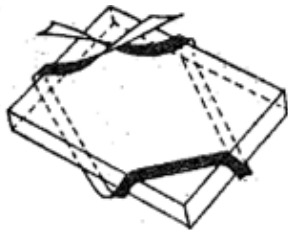

III. MAKING BOWS

The secret to a beautifully wrapped package lies in the making of the bow. By following a few fundamental rules as to color, proportion, methods of looping, gathering, tying ribbon – and by practice – anyone can make bows successfully. Keep the following rules in mind:

1. Make the bow separately and attach it to the package.
2. Make loops in proper proportion to the width of the ribbon. The narrower the ribbon, the shorter each individual loop should be, and the more loops, the puffier the bow.
3. Be lavish with ribbon and make plenty of loops. In general, keep loops the same size. Special effects with long and short loops are also possible.
4. When pinching ribbon together to form loops, make tiny pleats or gathers.
5. When using ribbon with a right and wrong side, keep the right side out at all times by turning the ribbon as necessary before making a loop.
6. Do not handle the ribbon more than is absolutely necessary.
7. Be creative and practice; bow making is a skill anyone can master!

There are only a few basic bows, but variations of these bows will give endless choices for dressing up gifts for all occasions. Learn these techniques, and soon you will be creating your own unique bows.

SIMPLE BOW

1. Loop both ends of a short piece of ribbon and attach.
2. Wrap a very short piece around the center and tape or glue the reverse side of the ribbon at the back.



BUCKLE

1. Make only one loop and notch the other end.
2. Attach a slim "buckle" of the same or contrasting ribbon.



FLAT BOW

1. Cut a piece of paper about the size you desire the bow to be.
2. Begin by stapling ribbon to paper.
3. Loop and staple again close to the first one. This can be repeated again and again, varying the size of the loop to create the effect desired.



BEGINNERS BOW

1. Using very thin ribbed ribbon, begin by making figure eight with ribbon between thumb and small finger.
2. Continue until bow is desired thickness.
3. Tie bow securely where ribbon meets.
4. Puff up ribbon and curl by running one side of scissors along length of ribbon. The ribbon can be cut and split to make even fuller bows.

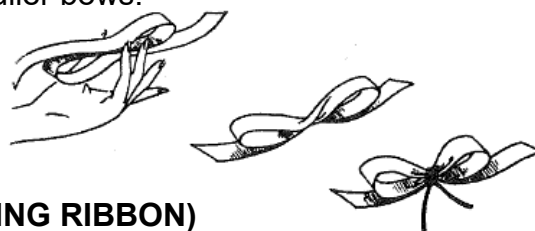

KNOTLESS BOW (SELF STICKING RIBBON)

1. For a 5 inch bow, cut 12 strips of self-sticking ribbon 11 inches long. Moisten both ends of one piece and press to the center.
2. Moisten one bow and attach it to a second. Set this pair aside. Repeat for the other pieces until there are 6 pairs.
3. Moisten the pairs, one by one, and attach them diagonally. Press a small loop in the center.



VARIATIONS OF THE KNOTLESS BOW

SUNBURST



1. Make a knotless bow.
2. Snip two slashes (from opposite directions) into the outer edge of each loop.

SWIRL BOW

1. Crisscross 4 pieces of 11 inch ribbon at center and attach (figure 1).
2. Join ends of each piece of ribbon to form a ball shape (figure 2).
3. Moisten the inside center of the crisscross. Twist top a quarter turn and press.

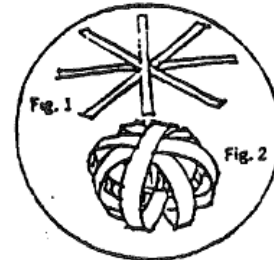

CIRCLE BOW (SELF STICKING RIBBON)

1. Moisten end of ribbon and form a small circle.
2. Continue going around enlarging circles and attaching at beginning point until desired size is reached.
3. Circle bows can be combined to make such things as butterflies; use your imagination.

Note: If you can't find self-sticking ribbon, use double sided tape to seal.



POMPOM BOW



1. Make a circle using 2 times the number of inches finished bow is to measure. Tape or paste the end securely.
2. Make 6 or more layers around the circle (the larger the bow, the more layers needed). Cut and secure the cut end.
3. Flatten the circle and, using forefinger to hold layers firmly against scissors, cut wedge-shaped pieces at both sides of each fold, leaving narrow 1/8" center.
4. Open circle, place notched edges together, and tie snugly with a narrow piece of ribbon.
5. With fingers inside the loops on one side, slip the inner loop out, pulling firmly toward you and twisting slightly. Slip the next inner loop out in the opposite direction, pulling and twisting as before.
6. Repeat until all loops are pulled free and pom-pom is full.

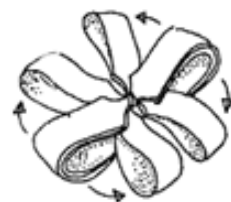

CURLED BOW #1



1. Curl one or more lengths of ribbon as shown.
2. Finish the bow by gathering curled length into loops and tying at center with a separate piece of ribbon.



CURLED BOW #2

1. Tie several short lengths of ribbon at the center and attach to package.
2. Holding firmly at the center, curl each individual strand of ribbon.

GLAMOUR BOW



1. A large glamour bow requires $2\frac{3}{4}$ yards of 2-inch wide ribbon. Three and one half inches from one end, pinch gathers in the ribbon and hold it between the thumb and fingers of the left hand.
2. Seven inches from this point, pinch gathers again and bring up to the first gathers to form a $3\frac{1}{2}$ inch loop.
3. If the ribbon has a right and wrong side, keep the right side out by turning the ribbon under the thumb and fingers as loops are made. With the right hand, continue making loops in the same way until you have twelve loops (six up and six down) and an extra end about $3\frac{1}{2}$ inches long. Wind wire or thread around the gathers to hold them in place.
4. When making this bow, adjust the length of the loops according to the width of the ribbon. A ribbon 3 inches wide requires $2\frac{1}{4}$ yards to make a bow of 10 loops. A ribbon $1\frac{1}{2}$ inches wide requires $2\frac{3}{4}$ yards to make a bow of 28 loops. The narrower the ribbon, the more loops necessary to make an attractive bow.

VARIATIONS OF THE GLAMOUR BOW

TWIN BOW

1. A glamour bow made from ½ inch ribbon can be nested on the center of a larger one made from 2 or 3 inch ribbon.
2. Use contrasting colors or kinds of ribbon.



CARRIAGE BOW

1. Use 3 inch ribbon and make a glamour bow which has only six loops and two ends.
2. Tie in center with narrow ribbon and arrange loops to form a circle. Make a second bow (using same or contrasting color) having only four loops and lay it on the top of the first bow (center on center).
3. Tie both bows together and attach to package.

DOUBLE BOW

Make bow as in carriage bow, but use a different kind of ribbon for the smaller, center bow. For instance use tinsel on satin, gold on green, silver center bow on big blue bow, a striped bow on a plain colored larger one, etc.

KNOTTED BOW

1. Use ribbon 1 ½ to 2 inches wide and about 2 yards long. Make a mark every 10 inches.
2. Tie a soft, loose knot at every other mark. Pinch gathers on the mark between knots and make loops as for original glamour bow. Knot should come at the center of the loop.
3. This is especially attractive in gauzy tinsel ribbon or soft satin.
4. When made from baby ribbon with knots about 5 or 6 inches apart and with 20 to 30 loops in all, you have a beautiful rosette.



LOOP BOW

1. This bow resembles a wheel. It requires two yards of $\frac{1}{2}$ inch ribbon – preferably firm or still. Ribbon must be alike on both sides.
2. Make a 3 or 4 inch loop about 5 or 6 inches from one end. Do not pinch together. Loop ribbon back and forth, making each loop directly under the one above, continuing until 14 to 16 loops have been made.
3. Wind fine wire around the center, taking care not to crush edges.
4. Lay on the package and spread loops apart at the center to form a perfect circle. Tape in place.
5. The circle effect may also be obtained by making two bows of fewer loops each and joining them back to back on the package to form the circle.

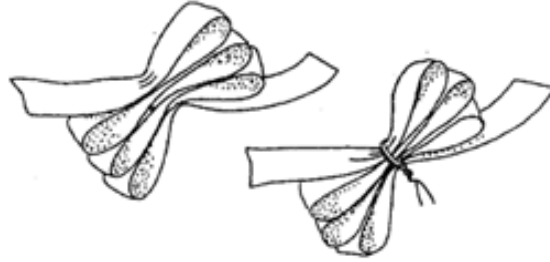

VARIATIONS OF THE LOOP BOW

FLAT EDGE BOW

Turn the loop inside out by pushing the bottom edge of the loop into the center, bringing up and back to original position.



TWO TONE BOW

If the ribbon has a right and wrong side, place two different colors of the same width ribbon with wrong sides together and make a flat edge bow.

TWISTED EDGE

Push the loop toward the center. Push the top edge down and under so that it turns inside out, to give the twisted effect.



LONG AND SHORT

1. Follow directions given for making the loop bow, but instead of winding the wire around the center, wind it nearer the top, so that the upper set of loops will be shorter.
2. The long and short version can be used as is, or the shorter loops may be bent down over the longer ones. It is especially pretty when made in two tone colors.

GRADUATED LOOP BOW

1. To make a graduated loop bow, start with a short loop on top and make each succeeding loop a little longer.
2. For an interesting effect, this bow may be made with narrow ribbon on top of a different color or kind of wider ribbon.



LAYER BOW

1. For this bow, ribbon must be alike on both sides.
2. Hold ribbon by its edges and fold loops back and forth on top of one another, making each one shorter than the one beneath.
3. Tie securely, pinching the loops tightly at the center, and attach to the package.
4. One and one quarter yards of ribbon will make a nice bow which has three loops on each side.
5. For a more decorative effect, make longer loops and turn them inside out as shown.



TAILORED BOW

1. To make a bow using ribbon having a right or wrong side, or to make one layer from a different color ribbon, the ribbon may be cut into graduated lengths and folded, as shown.



2. Turn both ends of each length under and fasten with tape or glue.
3. Lay the longest piece on the bottom and arrange the other pieces in layers.
4. Tie or tape all together and cover the center with a small piece of ribbon, keeping the seam underneath.
5. Attach bow to package.

WREATH BOW

1. This tailored bow requires 2 ½ yards of ribbon 4 or 5 inches wide. Cut the ribbon into the following lengths: 16 inches, 20 inches, and 24 inches. The 30 inch piece remaining is used for ends.
2. Fold ends of each piece to the center, overlap, and hold in place with two or three stitches.
3. Arrange loops in layers and pinch all centers together. Tie securely with narrow ribbon or wire. Tie the 30 inch piece around the center, knotting it in back, and allow ends to fall as streamers.
4. This bow may be made with only one or two loops if preferred.



HAIR BOW

1. Place ribbon in S or double S shape, keeping right side up.
2. Cover with the open hand and gather ribbons together between the first and second fingers.
3. Tie in the center and attach to package.
4. Slip a bobby pin under the loop on the back of bow and it will be ready to be worn in the hair also.
5. This is a pretty bow for any feminine gift and is especially suitable for children's packages.



PINWHEEL BOW

1. From 1 inch ribbon, cut 4 pieces, each 5 ½ inches long.
2. Wind thread around the center of each piece and tie tightly.
3. Arrange the 4 pieces in wheel form and tie together. Cut ends diagonally, in fishtail shape or with pinking shears.



4. Ribbon may also be cut into short lengths and grouped 5 to 6 pieces together. Ends may be fringed or notched.
5. Odds and ends of various colors and kinds of ribbons may be combined to make effective use of leftovers.

POINSETTIA BOW

1. For a medium sized poinsettia bow, use ribbon between 2 and 3 inches wide. Use a red satin ribbon with a very crisp finish.
2. If the ribbon is 2 inches wide, measure off with pins along the selvage at 2 inch spaces, the whole length of the ribbon. If 3 inch wide ribbon is used, place the pins 3 inches apart.
3. Cut across ribbon in diagonal lines to form petals.
4. Pinch gathers along the straight grain of the ribbon as indicated by dotted lines.
5. Hold gathers in place by twisting tightly with thread. Arrange three petals to form a 6 pointed flower.
6. Fill in the center with a knot of yellow baby ribbon or with a yellow flower center.

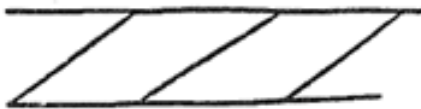

PUSSY CAT BOW

1. To make this bow, cross ends over as shown.
2. Wind the center with thread or wire.
3. If desired, center may be covered with narrow baby ribbon, or an object may be added to make the package more attractive or to give the receiver of the gift a clue as to the contents of the package.



FIGURE 8 BOW

1. Work ribbon back and forth in loops in the form of a figure 8. Firm ribbon works best. It may be easier to make the bow in reverse position.
2. Turn the bow upside down and make the figure 8 small to start with, making each one successively larger.

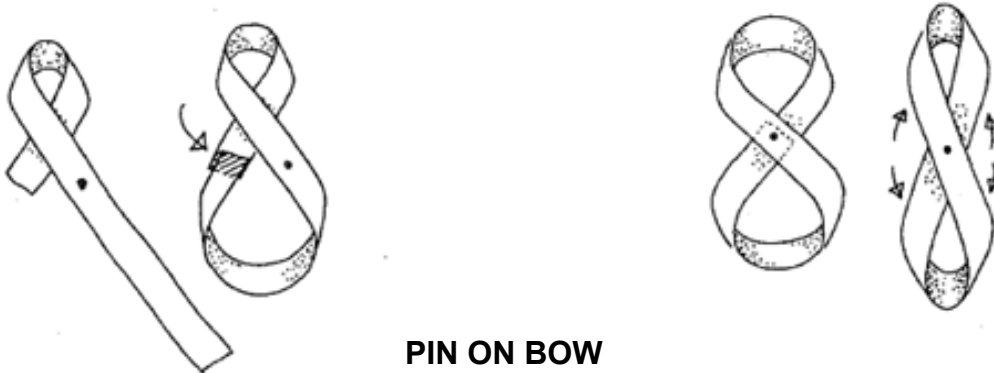

PIN ON BOW

1. Use 24 inches of ribbon and make a loop 3 inches long about 3 or 4 inches from one end.
2. Pinch gathers and hold between thumb and finger of right hand.
3. Pick up longer end near this point and bring it around under the finger of right hand and up over fingernail, then down under the center and push with left thumb through a space between right hand fingernail and the ribbon that covers it.
4. Catch the loop thus formed with the right thumb and finger as you let go of the first loop.
5. Pull both loops to tighten knot.





RUFFLE BOW

Ruffle one edge of a 27 inch length of ribbon 2 or 3 inches wide, and shape into a rose. This can be used instead of a bow.

STAR TRIM

1. Use 1 ½ inch wide ribbon. Cut 4 inch pieces and fold in funnel shape by lapping ends to form petals.
2. Arrange petals to form a star and stitch ends together.
3. Additional decorative items may be added to center of star.



KNOTTED TRIM

Tie a knot in the center of short lengths of ribbon and pin or tape to package. This is a good way to use up odds and ends.

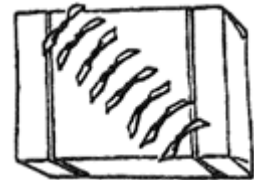

ADDING DECORATIVE TRIMMINGS

Many beautiful and unusual packages may be created by combining bows with other trimmings, and by the use of novel arrangements.

TOYS – Small plastic or metal toys make excellent trims for children’s gifts. Some toys may even be used as miniatures on an adult gift, such as a small hoe and rake for a gardening friend.

CANDY – Lollipops, candy canes, and other wrapped candies are a delightful addition on a child’s gift.

CHRISTMAS ORNAMENTS OR BELLS – Small Christmas ornaments make festive additions to Christmas gifts. Silver or gold colored bells may be used on special anniversary gifts and are pretty on Christmas gifts also.



STICKERS – Stars, hearts, and any other appropriate stickers may be attached to packages as decorations or may be used as seals.

GLITTER OR SNOW – Outline a simple design with glue and sprinkle it with glitter or let it “snow” on a Christmas tree in the same manner.

CUTOUTS – There are many ways to use pictures cut from magazines or old greeting cards. One suggestion is to cut a slit in the wrapping paper like a plus sign. Insert the picture under the paper and secure with glue or rubber cement. Roll back the points of paper on a pencil to make an attractive frame for the picture.



CANDY CANE – Lay stripes of red tape diagonally across a piece of white cardboard. Draw a candy cane on another piece of paper to use as a pattern. Using the candy cane pattern as a guide, trace the outline of the cane and cut it out carefully.

FLOWERS – Silk or dried flowers make a package look dainty and feminine. Flowers can often be salvaged from an old hat, corsage, or table arrangement. Swish flowers in soapy water to remove dust. Many times a good steaming will refresh them.

GREENERY AND PINE CONES – Evergreen, holly, mistletoe, or any other type of greenery make nice additions to Christmas gifts. Be sure to use fresh material in good condition. Pine cones need not be fresh, but should be clean and in good condition. Pine cones may be cut horizontally through the center to make small flowers. These are especially attractive when coated with a clear finish or painted.

PAPER LACE DOILIES – These inexpensive decorations can be used in many ways. A doily, cut in half, may be pleated to make a fan and may be used in place of a bow. A doily makes a pretty ruffle for the background of such things as a sachet bag or flowers. Small doilies, cut in half, may be arranged in a scalloped pattern, or in any number of creative ways on the gift.

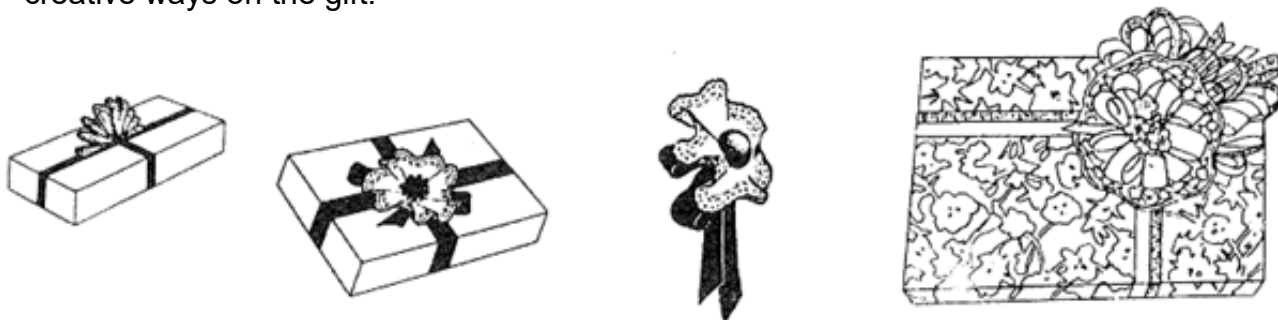

IV. DECORATING YOUR OWN PAPER

Give your gifts a personal touch with gift paper you have decorated. With only a small expenditure of time, energy, and money, you can print reams of your own unique gift wrap paper. Use shelf paper, brown wrapping paper, paper toweling, etc., to print your own designs using one of the methods described in this manual, or use any other idea you come up with.

ROLLER PAINTING

Rollers may be used to decorate shelf paper. To achieve startling effects, follow these directions:

1. Allow an adequate work area. A 3 to 6 foot table or sawhorse with boards is ideal. Lay papers on the floor for protection against spatters and spills.
2. Pour a variety of water based paints into bowls or saucers.
3. Unroll shelf paper and cut into 3 to 6 foot lengths.
4. One roller is all you need to create bold stripes. Alternate the widths of the stripes by using the edge of the roller to make a very narrow stripe, or create a checkerboard motif by rolling a roller for a few inches and then lifting it from the paper. The color blocks will be uneven, but will give the paper a unique look.



STRING PULLING

Instructions for this ancient method of decorating paper are as follows:

1. Using shelf paper or ordinary brown wrapping paper, cut into 1 or 2 yard lengths. Shorter lengths are easier to work with.
2. Assemble ordinary postal string, or heavier twine if thicker outlines are desired. Cut string no longer than an arm's length.
3. Dip the string in poster paint, squeeze out the excess, and lay in swirls and loops on the paper. Leave part of the string hanging over the paper.
4. Fold a square of newspaper over the coiled string and hold it in place, exerting a gentle pressure.
5. With the other hand, quickly pull the string, which extends from between the newspaper and the shelf paper, toward you with one continuous motion.
6. Remove the newspaper and allow the design to dry thoroughly. Do not use more than two colors.

FRUIT, VEGETABLE, AND UTENSIL PRINT PAPER

Fruit, vegetable, and utensil print paper can feature a wild collection of items that may be found in most supermarkets any time of the year. To make these papers, use some new variations of the well-known potato printing technique.

1. For potato printing, cut the vegetable in half and make a few notches with a paring knife. If the potato is not particularly shapely, trim the edges into any desired outline.
2. Dip the potato in paint and press it to the paper.
3. For a striking effect, alternate rows of vegetable print with bands made from a roller.
4. After mastering the potato print, graduate to other fruits and vegetables. Try a cabbage cut in wedges or make wagon wheels from lemon slices. Use half an apple to make the print, and add seeds and stem with paint or marking pen. Also try designs made with kitchen utensils such as wire whisks, cookie cutters, or gelatin molds.

KITCHEN PAPER TOWELING AND LIQUID DYE

Kitchen paper toweling and liquid dye make simple but sensational shadow designs. The end result will resemble an expensive batik or tie dye paper. And best of all, you can turn out yards of superb looking paper in a few hours.

To make a large amount of wrapping paper:

1. Re-roll about $\frac{3}{4}$ of a regular size roll of plain colored paper toweling on the cardboard core from the inside of the roll. Do not roll it too tightly.
2. Fill a small basin with $\frac{1}{2}$ cup dye and same amount of water. Repeat the process with another color.
3. Immerse one end in one color, allowing it to remain in solution for about 1 minute. For lighter shades, double the amount of water.
4. Wearing plastic gloves, remove the toweling from the dye and squeeze out all excess water.
5. Repeat the process with another color at the other end of the toweling.
6. Unroll paper carefully and loop it over a clothesline for drying.

For shorter lengths of dip dyed paper:

1. Fold 6 or 8 squares of paper toweling into a very compact square.
2. To produce a feathery effect, immerse each corner in a different color of dye for about $\frac{1}{2}$ minute.
3. Or fold paper toweling into triangles and dip the corners of the triangles.

STENCILING

Purchase or make a stencil pattern and create imaginative designs for a personalized gift.

1. Using stencil paint and brush, paint over stencil on plain paper.
2. If stenciling in more than one color, allow paint to dry before changing colors.

STAMPING

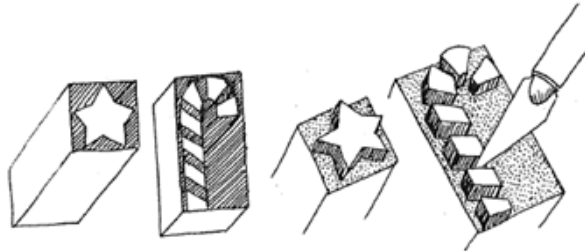

Stamping is another technique that may be used to create unique wrapping paper for that special gift. Use purchased stamps or make your own.

MATERIALS NEEDED TO MAKE YOUR OWN STAMPS

- brown wrapping paper
- colored ink stamp pads or small bowls of poster paint
- scraps of wood
- sharp scissors
- white glue
- 1/8 in thick latex foam (such as Dr. Scholl's Adhesive Foam, available at most drug stores)
- pencil erasers for printing dots
- mat knife
- ruler

INSTRUCTIONS:

1. Cut foam pieces into shapes (boys, girls, trees, hearts, houses, etc.) and glue them to small blocks of wood to make stamps. Make sure that edges of each figure are cut cleanly. Use mat knife to trim small areas, if necessary. For easier handling, blocks should be slightly larger than figure to be stamped.
2. For a repeated design, use a ruler to draw a lightly penciled guideline on brown paper. Press a stamp firmly and evenly on the stamp pad or bowl of paint, and print a row of figures along the penciled line, re-inking the stamp as necessary. Draw more lines and print other figures along the row, alternating patterns if desired. Print larger figures first, then fill in with pencil eraser dots and with other small shapes. Work from top of sheet down, to avoid smudging preceding rows. A marking pen may be used to draw extra lines if desired.
3. Stamping may also be done in a random manner on the paper.

SPATTER AND SPRAY PAINTING

Do you wonder what to do with paint left over from previous projects? Use it to turn plain paper into a delightful wrapping for a special gift.

1. Lay paper lace doilies on the paper and spray paint over them to produce a delicate design. Try painting over leaves for another effect.
2. There are several ways to spatter paint. Try placing screen wire over plain paper and running a toothbrush dipped in paint over the surface. Painting over a comb also gives interesting results. Spatter painting may be messy, so be sure your work surface is protected.

OTHER IDEAS

If you are the kind of person who really likes to get your hands into a project, making gift wrapping paper provides you with an excellent opportunity. Here are a few fun ideas for your consideration:

1. Dip the palm of your hand in poster paint and make handprints all over shelf paper or brown wrapping paper.
2. When you have this mastered, try making bear tracks across the paper; dip just the palm of your hand in the poster paint and make the palm print on the paper. Then dip your fingers in the paint and print them just above the palm print.
3. Try making footprints on snow white shelf paper. This design is created by a clenched fist print, four fingers, and a thumbprint. Splash them at random over the paper or arrange them so they appear to march over or around the gift box.

These designs should give you a few clues of your own. Put them into action by working on your own personalized gift wrapping paper. With a little practice, the work will seem like play!



V. GIFT BAGS

If you cannot seem to wrap it, bag it! The instructions for the two types of bags in this section should cover your needs, whether you are wrapping a small or a large gift. Be sure to remember that you will need sturdier paper and ribbon than you might otherwise use on a boxed gift. If you have a lightweight paper that you would like to make into a bag, use freezer paper as lining and strong support.

EASY GIFT BAGS

You'll get a perfect bag every time if you use this fool-proof method:

1. Start with a sheet of paper about twice as large as the bag you want to make. You can use any kind of paper imaginable.
2. Fold the paper over about 1 inch along the length. Using a box the size of the bag you're making, place the box in the center of the wrap, and bring the two long sides of the paper together, taping them to one another. Be sure you secure these loosely enough so that the box can be easily removed.
3. Tape one end of the package closed as you would if wrapping a gift box. Do not tape the paper to the box at any point.
4. Remove the support box. Stand the bag upright and fold about 1 inch of the open end into the bag, giving a nice, neat finish to the top.
5. For handles, attach a length of ribbon from one side of the bag to the other, or use two smaller handles, one at the front of the bag and one at the back.

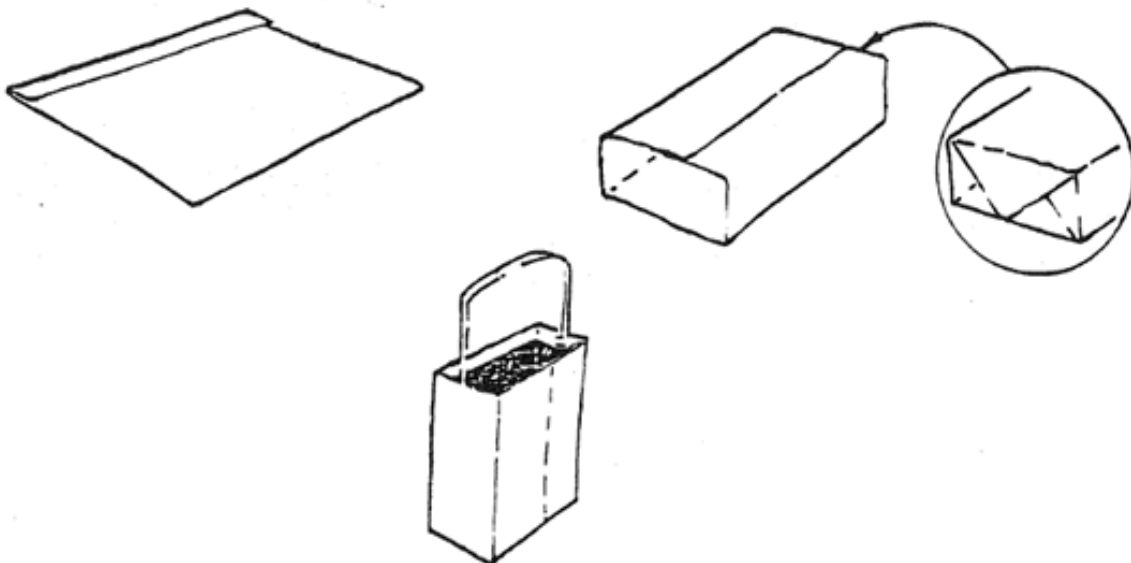

You will probably find a time when you will need to wrap a gift and send it by parcel post or parcel service. You will want your gift to arrive in good condition. Wrapping it properly and addressing it carefully will help insure this.

There are several guidelines you need to follow for the Post Office to deliver your package:

1. Use a sturdy container.
2. Cushion the contents - bottom, sides and top.
3. Close it securely. Do not use wrapping paper and twine, instead, use reinforced tape to close the carton, (strapping tape is good).
4. Label it correctly. Include a duplicate label inside the carton. Mark clearly the name and complete address, including zip code, of the sender and receiver. You may include special markings such as "fragile", etc., in three separate places: (above the address, below the postage and on the reverse side).

If you are sending your package with another carrier, (U.P.S., FedEx, etc.), you need to find out if their guidelines are any different than the above.

Normally, packages should not exceed 70 pounds in weight and 108 inches in length plus girth, (the measurement around the carton). The girth and length should not exceed 130 inches. **Remember:** Check with the service delivering your package to make sure these measurements have not changed. Also remember that the more a package weighs, the more it will cost to send it.

VII. WRAPPING WITHOUT A BOX

Wrapping without a box is never as satisfactory as wrapping with one. On occasion, however, we have no choice and must do the best we can with odd shaped gifts. This can really test your creativity.

Although your gift item may not fit in a box, whenever possible make a tube for a long narrow item by rolling a piece of corrugated cardboard around it to form a cylinder or cut 2 square cornered pieces of cardboard to fit above and below the item. This, at least, gives you edges to work with.

Gifts that have some form, such as bowls, jars, open topped boxes, etc., may be wrapped with cellophane or tissue paper in the following manner: Cut 2 squares of paper large enough to cover the gift plus an ample amount to give a nice spreading effect at the top when tied. Overlap the squares as shown and place the gift in the center. Bring all eight corners together over the top of the gift and tie a piece of ribbon or cord over the center top of the gift. Fan out the paper evenly above the knot and decorate as you like.